

LOW ANGLE ROPE RESCUE OPERATIONAL

Approved and Adopted by the
Office of State Fire Marshal

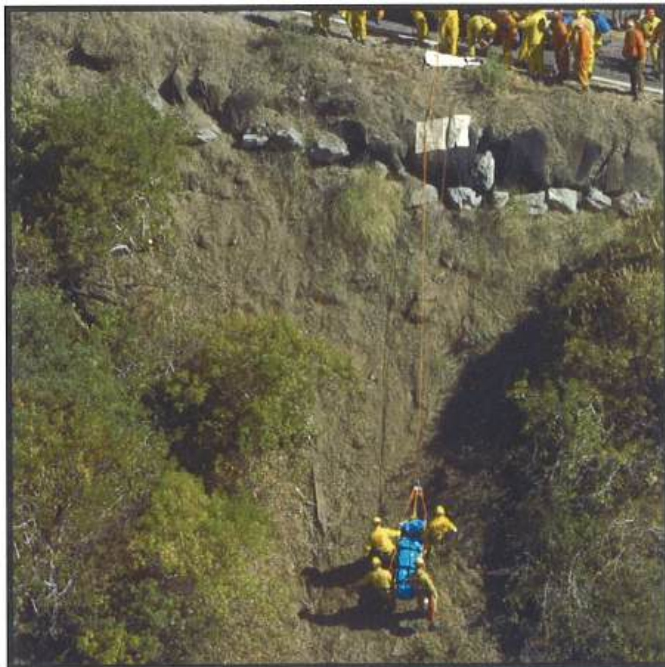

Recommended by the Statewide Training
and Education Advisory Committee
and the State Board of Fire Services



INSTRUCTOR and STUDENT MANUAL

January 2007



LOW ANGLE ROPE RESCUE OPERATIONAL

INSTRUCTOR AND STUDENT MANUAL



Published by

STATE FIRE TRAINING
PO Box 944246
Sacramento, CA 94244-2460

Second Printing, May 2007



LOW ANGLE ROPE RESCUE OPERATIONAL



Mission Statement	i
Fire Service Training and Education Program.....	i
Acknowledgments	i
Course Approval.....	iii
Course Outline	iv
Texts and References	v
Revisions to the Low Angle Rope Rescue Operational Manual.....	v
Sample Calendar of Events.....	vi
Chapter 1: Course Introduction	1
Course Overview.....	1
Low and High Angle Rope Rescue Definitions.....	1
Rescuer and Victim Safety Considerations.....	1
Student Evaluations.....	2
Chapter 2: Rope Rescue Equipment.....	4
Kernmantle Rescue Rope.....	4
Prusik Loop	10
Webbing	11
Load-releasing Device	12
Commercial Harness	13
Carabiner	15
Brake Bar Rack	17
Figure Eight Plate with Ears	18
Rescue Pulley	20
Mechanical Grab Device.....	21
Anchor Plate.....	22
Edge Protection	23
Chapter 3: Rescue Knots and Hitches	25
Qualities of a Rescue Knot.....	25
Rope Terminology	25
Components of Knots and Hitches.....	26
Hitches	27
Knots	28
Chapter 4: Anchor Systems	44
California Code of Regulations, Title 8, Section 1670.....	44
Considerations When Selecting Anchors.....	44
Types of Anchors	45
Sling Anchor Attachments: Pretied.....	46
Single Sling Anchor Attachments: Open	51
Multi-Point Self-adjusting Anchor Systems	53
Windlassed Picket Systems.....	57
Chapter 5: Rescuer and Ambulatory Victim Packaging.....	61
Rescuer Packaging	61

Sample NFPA Class II Harness Instruction Card	62
Ambulatory Victim Packaging Overview	63
Sample Victim Harness Instructions	63
Chapter 6: Types of Litters and Victim Packaging	69
Rescue Litters	69
How to Secure a Victim to a Rescue Litter	71
Alternative Victim Packaging (Optional)	75
Considerations for Packaging Nonambulatory Victims in Unstable Terrain	78
Chapter 7: System Attachments and Fall Restraint	79
Rescuer Attachment to a Rope Rescue System	79
Ambulatory Victim Attachment to a Rope Rescue System	80
Rescue Litter Attachments to a Rope Rescue System	81
Rescuer Attachment to the Litter System	82
Litter Harness Pre-rig	82
Three Rescuer Litter Attachment	84
Four Rescuer Litter Attachment	85
Fall Restraint	86
Components of a Fall Restraint System	87
Chapter 8: Three Main Components of a Rope Rescue System	89
Key Points about the Component Approach	89
Single RPM Configuration	91
Prerigged Dual RPM Systems	92
Chapter 9: Belay/Safety Line Systems	94
Key Points Regarding the Operation of Belay/Safety Line Systems	94
Belay/Safety Line Configurations	95
Lowering Operations – Basic Configuration	96
Retrieval Operations – Basic Configuration	97
Lowering Operations – PMP Configuration (Optional)	98
Retrieval Operations – PMP Configuration (Optional)	99
System Variations	99
Chapter 10: Descending/Ascending	101
Descending	101
Rigging a Fixed Line	102
Rappel Position	105
Ascending	115
Chapter 11: Lower/Raise (Mechanical Advantage) Systems	117
Key Points Regarding Lower/Raise Operations	117
Lowering Line Systems	118
Raising (MA) Systems	119
Lower to Raise Conversion: 3:1 Inline – RPM	119
Lower to Raise Conversion: 5:1 Inline – RPM	121
Lower to Raise Conversions	122

3:1 or 5:1 Inline with Directional Pulley	123
Piggyback Systems	127
Pig Rig Construction: 3:1	128
Pig Rig Construction: 5:1	129
Lower to Raise Conversion: 3:1 Pig Rig	130
Lower to Raise Conversion: 5:1 Pig Rig	134
Chapter 12: Load-releasing Methods	139
Rappelling or Lowering Operations	139
Raising Operations	142
Chapter 13: Rescue Scene Organization and Management	147
Command and Control in Low Angle Rope Rescue Operations	147
Considerations for the IC	151
Introduction to Rope Rescue Lowering and Raising Systems	154
Example Organization of a Low Angle Rescue Using 3-Person Engines	157
Sample Organization Chart	159
Chapter 14: Litter Walkouts	165
The Simple Walkout	165
The Caterpillar Walkout	166
The Single Pitch Walkout with a Belay/Safety Line	166
The Multiple Pitch Walkout with a Belay/Safety Line	167
Staffing	167
Ladders used in Litter Walkouts	169
Chapter 15: Ladder Rescue Systems	170
Moving Ladder Slide	170
Ladder Slide	174
Chapter 16: Evolutions	179
Evolution Components	179
Appendix A: Student Task Book	201
Responsibilities	201
Instruction for Completing the Task Book	201
Appendix B: Glossary	211
Appendix C: Graphics Index	215
Appendix D: Training Site Requirements	221
Low Angle Rope Rescue Operational Equipment Inventory	223
Appendix E: Instructor Levels and Requirements	225
Instructor Levels	225
Instructor Qualifications	225
Maintaining Primary Instructor Status	227
Appendix F: Instructor Trainee Task Book	229
Responsibilities	229
Instruction for Completing the Task Book	229



LOW ANGLE ROPE RESCUE OPERATIONAL



Mission Statement

Mission Statement

The mission of State Fire Training is to enable the California fire service to safely protect life and property through education, training, and certification.

Fire Service Training and Education Program

The Fire Service Training and Education Program (FSTEP) was established to provide specific training needs of local fire agencies in California. State Fire Training coordinates the delivery of this training through the use of approved curricula and registered instructors.

The FSTEP series is designed to provide both the volunteer and career fire fighter with hands-on training in specialized areas such as fire fighting, extrication, rescue, and pump operations. All courses are delivered through registered instructors and can be tailored by the instructor to meet your department's specific need. Upon successful completion of an approved FSTEP course, participants will receive an Office of State Fire Marshal course completion certificate.

Acknowledgments

The development of this technical rescue system training curriculum was made possible through cooperation and collaboration between the Office of State Fire Marshal/State Fire Training, the Governor's Office of Emergency Services Fire & Rescue Branch (Special Operations Division), and the California Fire and Rescue Training Authority at Sacramento. Before its publication, the Statewide Training and Education Advisory Committee (STEAC) recommended this guide for adoption by the State Fire Marshal. This guide is appropriate for fire service personnel and for personnel in related occupations.

**State Fire Marshal
State Fire Training**

**Governor's Office of
Emergency Services**

**California Fire & Rescue
Training Authority**

Ruben Grijalva Director of CDF	Henry Renteria Director	Dave Baltzell Facility Manager
Kate Dargan State Fire Marshal	Kim Zagaris Fire Chief	Sherri Martucci Administrative Assistant
Michael Richwine Chief, State Fire Training	Charles D. Hurley Deputy Chief, Special Operations	

Special acknowledgement and thanks are extended to the following members of State Fire Training for their diligent efforts and contributions that made the final publication of this document possible.

<p>Alicia Hamilton Fire Service Training Specialist</p>
<p>Rodney Slaughter Deputy State Fire Marshal</p>

The material contained in this document was compiled and organized through the cooperative effort of numerous professionals within, and associated with, the California fire service. We gratefully acknowledge the following individuals who served as principal developers for this document.

<p>Jim Mendonsa, Team Leader Columbia College, Retired</p>	
<p>James Bishop CDF/Tuolumne Calaveras Unit</p>	<p>Matt O'Donnell Ebbetts Pass Fire District</p>
<p>John Brenner Sacramento Fire Department</p>	<p>Matt Loughran Fremont Fire Department</p>
<p>Steve Herzog CDF Academy</p>	<p>Kevin Southerland Orange Fire Department</p>
<p>Van Riviere Stockton Fire Department</p>	<p>Jeff Speegle, Graphic Development Stockton Fire Department</p>

We also thankfully acknowledge the following individuals who served as contributors to this document.

<p>Patrick Bell OSHA</p>	<p>Mike McGroarty OES, Retired</p>
<p>Paul Cole Half Moon Bay Fire Protection District</p>	<p>Steve Morikawa Santa Rosa Fire Department</p>
<p>Andy Mauer, Graphics Assistance Trout Stream Designs</p>	<p>Ernie Ojeda Los Angeles Fire Department</p>

Course Approval

In May 2007, the U.S. Department of Homeland Security formally approved this course and issued the following:

U.S. Department of Homeland Security
Washington, DC 20472

 **FEMA**

May 10, 2007

MEMORANDUM TO: Mr. James Ayre
California Office of Homeland Security
9800 Goethe Road
Box 56
Sacramento, CA 95827-3563

FROM: Steven Schuetz
Acting Director, Training
Training and Exercises Integration
National Integration Center

SUBJECT: State and Local WMD Training Program
Analysis and Validation

The purpose of the State and local WMD training program analysis and validation process is to ensure that state and local jurisdictions seeking National Integration Center (NIC), formally the Office of Grants and Training (G&T) approval of their WMD training course materials are submitting training products that are congruent with the standards and guidelines of the NIC training partner course assessment and approval process.

Upon receiving the Training and Education (TED), formally the G&T Training Division, Training Approval Template submission for the **Low Angle Rope Rescue Operations** course, the Center for Domestic Preparedness (CDP) conducted a desk audit of the course materials based on the completed template, the completeness of the materials submitted, and the content to determine if the training materials were consistent with NIC standards.

Analysis and evaluation of the submitted materials found that the training course met the required standards. The basis of this conclusion is contained in the attached course evaluation, observations, and findings.

Any questions regarding this audit should be directed to Christina Humphries, Evaluations and Standards Branch, Center for Domestic Preparedness, Anniston, Alabama, (256) 847-2108 or email: HumphriesC@cdpemail.dhs.gov

COURSE EVALUATION, OBSERVATIONS, AND FINDINGS

TRACKING NUMBER: 061122-01R
COURSE TITLE: Low Angle Rope Rescue Operational
LENGTH: 24.0 hours
REVIEWED BY: Christina Humphries
COURSE LEVEL: Performance Defensive – Operations
COURSE AUDIENCE: Search and Rescue
SUBMITTING AGENCY: State of California
G&T COURSE APPROVAL RECOMMENDATION: APPROVAL

OVERALL COMMENTS ON THE COURSE

- **Mechanical / Structural requirements:**
All required structural elements are present and acceptable.
- **Factual / Content requirements:**
To best serve the G&T mission this course should be delivered in conjunction with additional WMD/CBRNE terrorism training. Completion (prerequisite or post-requisite) of this training should be enforced as a condition of G&T recognition and support. This requirement should be indicated in the course catalog.

SCORECARD RESULTS and COMMENTS

Training Support Package (TSP)

- *Instructor Guide/Instructor Outline/Instructor Lesson Plans* — (2) acceptable
- *Participant Manual/Participant Guide/Participant Workbook* — (2) acceptable
- *Audio Visual Support Materials* — (2) acceptable
- *Special Support Materials* — (2) acceptable

Module/Session/Lesson Content

- *Scope Statement* — (2) acceptable
- *Terminal Learning Objective* — (2) acceptable
- *Enabling Objectives* — (2) acceptable
- *Resource Lists* — (2) acceptable
- *Instructor to Participant Ratio* — (2) acceptable
- *Reference Lists* — (2) acceptable
- *Practical Exercise(s) Statement* — (2) acceptable
- *Evaluation Strategy* — (2) acceptable



LOW ANGLE ROPE RESCUE OPERATIONAL



Course Outline

Course Outline

Course Objectives: To provide the student with...

- a) Information on rope rescue equipment, rescue knots and hitches, anchor systems, system attachments and fall restraint, belay/safety line systems, load-releasing devices.
- b) Methods and techniques used to inspect and maintain rescue rope, webbing, and hardware.
- c) Methods and techniques to tie knots and package victims and rescuers.
- d) Methods and techniques for using rescue equipment to build lower/raise (mechanical advantage) systems.
- e) Information on rescue scene organization and management.
- f) An opportunity to demonstrate and apply basic low angle rope rescue techniques.
- g) Optional information on litter walkouts and ladder systems used in low angle rope rescue operations.

Course Content	24:00
1. Introduction	1:00
2. Rope Rescue Equipment	1:00
3. Rescue Knots and Hitches	1:00
4. Anchor Systems	2:00
5. Rescuer and Ambulatory Victim Packaging	1:00
6. Types of Rescue Litters and Victim Packaging	2:00
7. System Attachments and Fall Restraint	1:00
8. Three Main Components of a Low Angle Rope Rescue System	2:00
9. Belay/Safety Line Systems	1:00
10. Descending and Ascending Techniques	2:00
11. Lower/Raise (Mechanical Advantage) Systems	3:00
12. Load-releasing Methods	1:00
13. Rescue Scene Organization and Management	1:00
14. <i>Litter Walkouts (Optional)</i>	1:00
15. <i>Ladder Systems (Optional)</i>	2:00
16. Evolutions	5:00
16. <i>Evolutions (Optional)</i>	5:00

Texts and References

- American Standards for Testing and Measures (ASTM) Standard F-1740
- ANSI Standards
- CCR, Title 8, Chapter 4, Division of Industrial Safety, Subchapter 4, Article 24, Section 1670 – Fall Restraint, State of California, 1998
- CMC Equipment and Instruction Cards
- Essentials of Fire Fighting, IFSTA, Fourth Edition
- Ferno Equipment
- Field Operations Guide, FIRESCOPE, Current Edition
- Government Code Section 8607
- Junkin Equipment
- NFPA 1006: Standard for Rescue Technician Professional Qualifications, 2003 Edition
- NFPA 1500: Standard on Fire Department Occupational Safety and Health Program, 2002 Edition
- NFPA 1670: Standard on Operations and Training for Technical Search and Rescue Incidents, 2004 Edition
- NFPA 1931: Standard for Manufacturer's Design of Fire Department Ground Ladders, 2004 Edition
- NFPA 1932: Standard on Use, Maintenance, and Service Testing of In-Service Fire Department Ground Ladders, 2004 Edition
- NFPA 1983: Standard on Life Safety Rope and Equipment for Emergency Services, 2006 Edition
- OSHA Regulations
- Rescue Systems 1 Student Manual, SFT, 2000 Edition
- Rope Rescue Manual, California Mountain Company, Third Edition
- Urban Search and Rescue Operational System Description, ICS-US&R-120-1, 2004 Edition

Revisions to the Low Angle Rope Rescue Operational Manual

Second Edition, May 2007

- Modifications made to the objectives at the front of each chapter.
- Modifications made to Figures 2-23, 4-13, 4-14, 4-26, 4-27, 4-28, 4-29, 6-7, and the Instructor Trainee Task Book.



LOW ANGLE ROPE RESCUE OPERATIONAL



Sample Calendar of Events

Sample Calendar of Events

DAY	CHAPTER	TITLE	TIME
1	1	Introduction	8:00
	2	Rope Rescue Equipment	
	3	Rescue Knots and Hitches	
	4	Anchor Systems	
	5	Rescuer and Ambulatory Victim Packaging	
	6	Types of Rescue Litters and Victim Packaging	
2	7	System Attachments and Fall Restraint	8:00
	8	Three Main Components of a Low Angle Rope Rescue System	
	9	Belay/Safety Line Systems	
	10	Descending and Ascending Techniques	
	11	Lower/Raise (Mechanical Advantage) Systems	
3	11	Lower/Raise (Mechanical Advantage) Systems (continued)	8:00
	12	Load-releasing Methods	
	13	Rescue Scene Organization and Management	
	14	<i>Litter Walkouts (Optional)</i>	
	15	<i>Ladder Systems (Optional)</i>	
	16	Evolutions	
			24:00

Minimum course hours = 24. If the optional skills and evolutions are scheduled to be taught, adequate time and materials must be added.

Chapter 1: Course Introduction

Scope: This chapter serves as an introduction to the course, providing students with general information and expectations of the course.

Terminal Learning Objective (TLO): At the end of this chapter, the student will be aware of the course goals, planned activities to achieve those goals, and the requirements for successfully completing the course.

Enabling Learning Objectives (ELO):

1. Describe the course objectives and an overview
2. Define low and high angle rescue
3. Describe rescuer and victim safety and personal protective equipment
4. Describe the student evaluation process

Course Overview

The Low Angle Rope Rescue Operational course is designed to provide training for responders in low angle rope rescue operations. These over-the-side operations may be the result of a vehicle accident, hiking mishap, swift water rescue, or search and rescue function in an urban or remote area.

This course will also provide training in a subject element required for the California Urban Search and Rescue (US&R) Basic and Light Operational Level by serving as the prerequisite training if you wish to continue your training in a Rescue Systems 1 course. Rescue Systems 1 prepares you for light-frame building collapse incidents caused by earthquake, terrorist actions, weapons of mass destruction (WMD) event, or other catastrophe.

The Low Angle Rope Rescue Operational course is a 24-hour course taught in a three-day format. Students will be grouped by squad, team, company, or other similar configuration. Each class session will begin on time, and your attendance is mandatory.

Injuries and/or Limitations

Notify your instructor of any previous injury or limitation you may have that would affect your participation in a training evolution. In addition, notify your instructor immediately of any injury sustained during any portion of the class.

Low and High Angle Rope Rescue Definitions

Low angle rope rescue refers to an environment in which the "on-rope" rescuers are predominately supported by the rescuers themselves and not the rope rescue system.

High angle rope rescue refers to an environment in which the "on-rope" rescuers are predominantly supported by the rope rescue system.

Rescuer and Victim Safety Considerations

A low angle rope rescue incident presents numerous hazards to the rescuers as well as the victim. The rescuers should assess and utilize proper safety precautions for the following:

- Fall restraint.
 - Steep, slippery edges or slopes.

- Overhead hazards.
 - Loose rock (scree), soils, or other objects that present overhead hazards to personnel below.
- Vectors.
 - Snakes, spiders, and ticks.
- Poisonous plants.
- Environmental conditions
 - Rain, snow, cold, and heat.
- Vehicle traffic.
- Water.
 - It is common for motor vehicles to run off elevated roadways into canals, lakes, and rivers.

Personal Protective Equipment

You should have the following personal protective equipment (PPE) in your possession at all times:

- Fire/rescue helmet or bump cap.
- Eye protection.
- Safety boots (lace-up style with lug sole is recommended).
- Leather gloves.
- Long-sleeve shirt or brush fire coat.
- Long or brush fire pants.

Your instructor will determine the amount of PPE you will wear for each training evolution. It is recommended that you apply sunscreen and bring ample drinking water for each session.

Student Evaluations

You will be evaluated both individually and collectively on a number of skills and evolutions. A task book will guide you and the instructor through the tasks required for successful completion of this course.

Individual Skills

1. Rescue knots and hitches.
2. Anchor systems.
3. Rescuer and ambulatory victim packaging.
4. Types of rescue litters and victim packaging.
5. Descending and ascending techniques.

Group Tasks

1. Windlassed picket systems.
2. System attachments and fall protection.
3. Three main components of a low angle rope rescue system.

4. Belay/safety line systems.
5. Lower/raise systems.
6. Use of load-releasing devices.
7. Evolutions.
 - Ambulatory rescue.
 - Nonambulatory rescue (3- and 4-tender).

Haul Systems

- Inline.
- Change of direction.

Mechanical Advantage Systems

- 3:1, 5:1.
- Piggyback 3:1, 5:1.

Optional Evolutions

- Litter walkout.
- Litter walkout with belay/safety line.
- Litter transfer with a ladder system.
 - Moving ladder slide.
 - Ladder slide.

Chapter 2: Rope Rescue Equipment

Scope: This chapter services as an introduction to rope rescue equipment.

Terminal Learning Objective (TLO): At the end of this chapter, the student will be aware of the equipment included in the two general categories of rope rescue equipment: software and hardware.

Enabling Learning Objectives (ELO):

1. Describe the components, use/misuse, types, construction, size/dimension, and inspection/maintenance for a kernmantle rescue rope, prusik loop, webbing, load-releasing device, commercial harness, carabiner, brake bar rack, figure eight plate with ears, rescue pulley, mechanical grab device, anchor plate, and edge protection

Equipment is divided into two general categories: software and hardware. Software includes rope, webbing, prusik loops, and commercial harnesses. Hardware includes carabiners, pulleys, anchor plates, descent control devices, and mechanical rope grabs. It is not the intent to promote any one manufacturer's equipment. Throughout this chapter, there will be references made to specific brands of equipment and their instructions for use. Your agency may possess or purchase different brands of similar equipment. It is up to you and your agency to follow the manufacturer's instructions for each piece of equipment.

The minimum breaking strengths provided in this manual are evaluated in laboratory conditions. Other factors, including how various pieces of equipment interface, their age, condition, and past use will affect the actual breaking strengths of life safety rope and equipment.

Kernmantle Rescue Rope

Components

- Kern = Core.
 - Continuous parallel fibers throughout the length of the rope.
- Mantle = Sheath.
 - Braided jacket.
 - Half of the strands have a left twist.
 - The other half has a right twist.
 - Eliminates twist when loaded.
 - Protects kern (core).
 - 10% - 25% of the rope's strength.

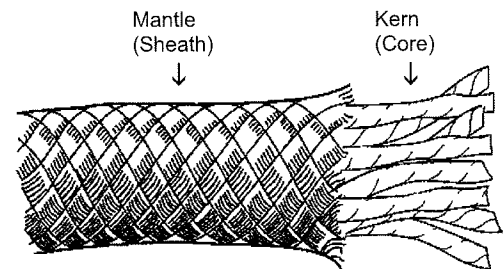

Figure 2-1: Kernmantle Rope

Use

- Primary tool for raising and lowering rescuers, equipment, and victims.
- Protects rescuers and victims as they move and work in elevated positions where a fall could cause injury or death.
- Used to create mechanical advantage systems.

Remember This Is Life Safety Rope! Treat It As If Your Life Depends On It!

Misuse

- Running the rope over sharp edges.
- Exposing the rope to excessive contamination from dirt and debris.
- Exposing the rope to excessive heat.
- Pulling or lifting vehicles.

Types

- High stretch (dynamic).
 - Greater than 10% stretch at 440 pounds force (1.95 kN).
 - May stretch to 60% at breaking strength.
 - Recreational climbing rope.
- Low stretch.
 - Has slightly more elongation than traditional static ropes.
 - Between 6% and 10% elongation at 10% of minimum breaking strength.
- Static.
 - Has slightly less elongation than low stretch ropes built to the same standard.
 - Less elongation prevents loss of system efficiency from rope stretch.
 - Preferred choice of the fire and technical rescue service.
 - ½" nylon kernmantle.
 - Most static kernmantle ropes have a thicker, tighter sheath than dynamic kernmantle ropes.
 - Provides additional protection to the kern (core) from abrasion and debris.
 - Less than 10% elongation at 10% of minimum breaking strength.



Figure 2-2: Dynamic Rope Core and Sheath

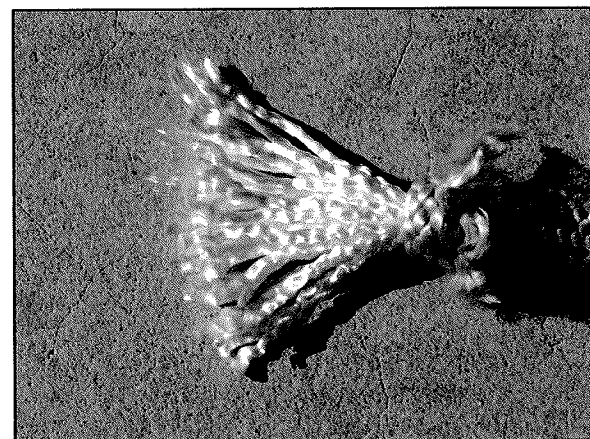

Figure 2-3: Static Rope Core and Sheath

Construction

- Only a few specially manufactured ropes meet the strength requirement.
- Kernmantle = core and sheath.
- Nylon (synthetic) is the most common.
 - Lighter.
 - Stronger.
 - More resistant to decay than natural fibers.
 - Loses 15% of its rated strength when wet, but quickly regains that loss when dried.

Size/Dimension

- ½" is most common.
- NFPA 1983 Standard on Fire Service Life Safety Rope and System Components compliant:
 - Two-person load (general use).
 - Minimum breaking strength of 40 kN (8,992 LBF).

Inspection/Maintenance

- Follow manufacturer's recommendations.
- Visual inspection.
 - Discoloration that could be from chemical contamination and/or sun exposure.
 - Burn marks from excessive friction and heat buildup.
 - Excess wear and abrasion of the sheath material.
 - Unusual wear.
 - Cuts.
 - Exposed core material.
- Physical inspection.
 - Soft spots.
 - Kinks.
 - Unusual bulges.
 - Inconsistent textures and flexibility.
 - Unequal diameter or thickness.
 - Excess contamination from dirt and debris.
 - Any of these could indicate damage to the core of the rope and may require taking a rope out of service.
 - If in doubt, take the rope out of service.

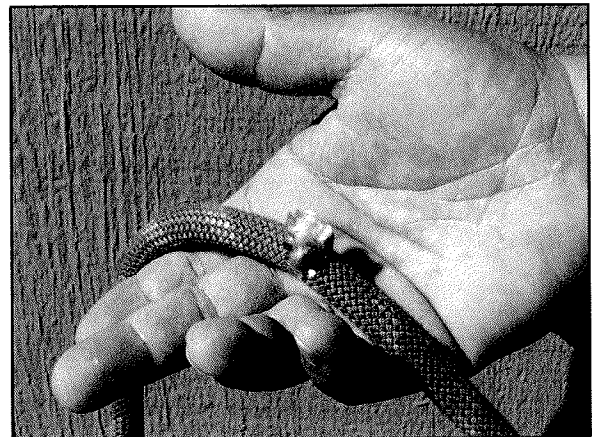

Figure 2-4: Visual Inspection

- ☐ Care and storage.
 - Stuffed into the rope bag for ease of deployment.
 - Do not coil.
 - Rope bag keeps the rope clean and protects it from ultra violet rays.
- ☐ Cleaning.
 - Keep clean of mud and dirt; can act as a sharp abrasive if allowed to work its way into the core of the rope.
 - Wash in a standard front-loading washing machine (should be placed in a dive bag or coiled), by hand in an open tub, or commercial rope washer.
 - Use cold water.
 - Do not use strong detergents.
 - May cause damage to the rope.
 - Ensure the rope is completely air dried before storing in a rope bag.
 - To avoid mildew and mold.
 - Do not dry in direct sunlight.
- ☐ Retiring/removing from service.
 - Excessive sheath wear.
 - More than half of the outer sheath yarns are broken in one pique.
 - After severe shock force from a fall or when stressed with a load beyond what it was designed to hold.
 - Contaminated by chemicals.
 - Worn out from use or age.
 - Inspection exposes an obvious fault or damage.
 - Usage cannot be accounted for.
 - The maximum life span for a lifeline is 10 years regardless of use per American Standards for Testing and Measures (ASTM) Standard F-1740.
 - Most rope manufacturers and rescue teams use a 5-year standard.
- ☐ Rope log.
 - Used for recording the usage of each rope and must be maintained.
 - Recorded information.
 - Purchase date.
 - Manufacturer.
 - Size.
 - Length.

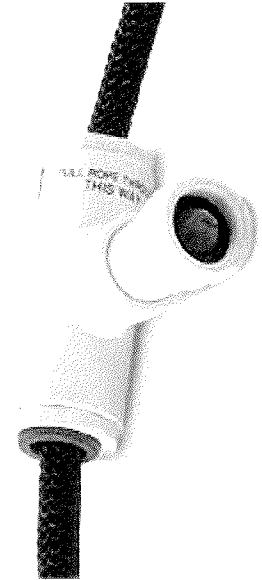

Figure 2-5: Rope Washer

LOW ANGLE ROPE RESCUE OPERATIONAL

- Whether it is high stretch (dynamic) or low stretch (static).
- Whether it is lifeline or utility grade rope (how the rope was used).
- Any unusual loading.
- Whether a fall was caught.
- Whether any object fell onto the rope.
- What materials (i.e., sand, glass, gasoline, etc.) the rope was in contact with.
- Washings.

slip e 2000#5

Prusik Loop

Components

- Kernmantle (same as rope).

Use

- Haul cam/prusik.
 - Pulls the rope into motion.
- Ratchet cam/prusik.
 - Prevents the rope from moving out.
 - Tended by a pulley.
- Braking cam/prusik.
 - Prevents the rope from moving out.
 - Tended by a person.

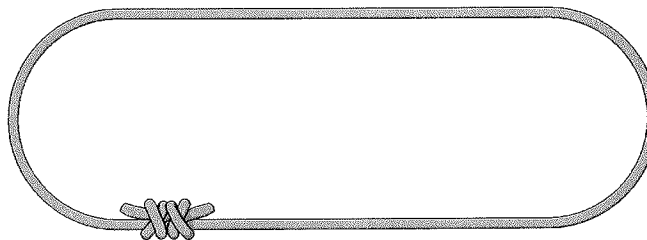

Figure 2-6: Prusik Loop

Misuse

- Same as rope.

Types

- Same as low stretch kernmantle.

Construction

- Double overhand bend is the preferred knot to form a prusik loop.

Size/Dimension

- 8mm for use on 1/2" rope.
- Length.
 - Variable depending on prusik minding pulley manufacturer.
 - Short prusik.
 - Should extend approximately 1" from pulley after being tied and set.
 - Long prusik.
 - Should extend 3"-4" beyond the short prusik.
 - Must extend in front of the descent control device after being set and formed.

Inspection/Maintenance

- Inspection (same as rope).
- Care and storage (same as rope).
- Cleaning (same as rope).
- Retiring/removing from service (same as rope).

Webbing

Components

- Varies, depending upon type of construction.

Use

- Build anchor slings.
- Build harnesses.
- Lashing.
- Load-releasing device.

Misuse

- Same as rope.

Types

- Flat
 - Constructed of a single layer or material.
 - Example: Seatbelt webbing.
 - Material is stiffer than tubular webbing.
- Shuttle loom (tubular webbing).
 - Has a continuous spiral of the fiber to form the webbing
 - Edge will not have a seam.
 - Due to manufacturing costs, shuttle loom is becoming more difficult to find.
- Needle loom (tubular webbing).
 - Formed by folding flat webbing lengthwise and stitching the two edges together.
 - Becoming the industry standard.

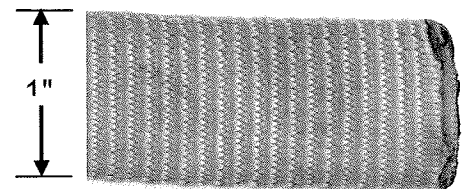

Figure 2-7: Flat Construction

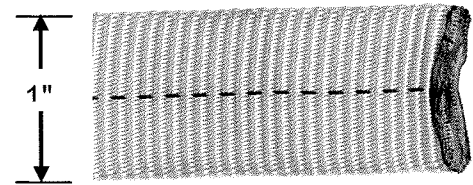

Figure 2-8: Shuttle Loom Construction

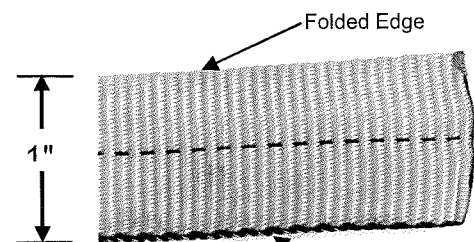

Figure 2-9:
Needle Loom Construction

Construction

- Nylon.
- Strong, lightweight, synthetic material.

Size/Dimension

- Width.
 - 1" is the most common in rope rescue.
- Length.
 - Green = 5 feet
 - Yellow = 12 feet
 - Blue = 15 feet
 - Orange = 20 feet
- Strength.

Orange = vcd

- 1" tubular nylon – 4,000 lbs.
- 1" solid (flat) nylon – 6,000 lbs.

Inspection/Maintenance

- Inspection (same as rope).
- Care and storage.
 - Commonly stored in the pocket of the rope bag.
 - Daisy-chained or doubled over and tied for organization.
- Cleaning (same as rope).
- Retiring/removing from service.
 - Same as rope, plus when weave is broken and/or the material is contaminated with petroleum products or other caustic chemicals.

Load-releasing Device *min. 5 wraps*

Components

- Premanufactured flat webbing with D-ring at one end, a sewn loop at the other end, and a floating position D-ring in the middle of the webbing.
- One general use carabiner to attach the webbing into itself.

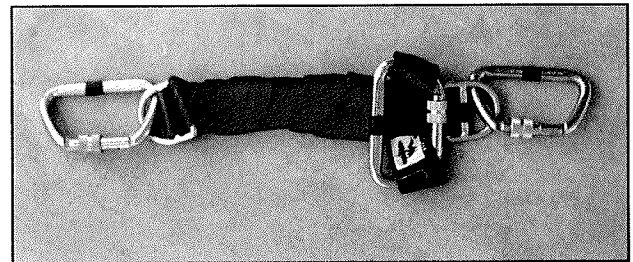

Figure 2-10: Assembled Load-releasing Device

Use

- Two primary purposes.
 - Transfer the load from the belay/safety line back to the main line.
 - If the belay/safety line tandem prusiks become loaded.
 - Has some shock absorbing capacity.
 - Can be used for changing over from a raising system to a lowering system or from a lowering system to a raising system.

Misuse

- Releasing the device without being certain that the load can be successfully transferred to another system.
- Attach backwards.
- Attaching the load-releasing strap carabiner to the anchor or load.

Types

- Manufactured strap (webbing).
- This course utilizes the manufactured strap design.
- Preassembled rope or accessory cord with carabiner.

Construction

- Webbing strap (flat nylon).
- D-ring.
- Floating D-ring.

Size/Dimension

- Webbing.
 - 1¾" wide.
 - 55" long.
 - Minimum breaking strength of 45 kN (10,120 LBF).

Inspection/Maintenance

- Inspection.
 - Same as rope, plus:
 - Buckle D-rings for cracks and elongation.
 - Webbing and stitching for fraying and excessive wear.
- Care and storage.
 - Same as rope plus do not drop or throw.
- Cleaning.
 - Do not put in a washing machine.
 - Follow manufacturer's instructions.
- Retiring/removing from service.
 - Weave is broken through.
 - Material is contaminated with petroleum products or other caustic chemicals.
 - D-rings are cracked or elongated.

Commercial Harness

Components

- Manufactured harness with or without padding.
- D-ring attachment in front.
- Adjustable waist and leg straps.
- Optional gear loops.

Use

- Attach rescuer or victim to a rope system.

Misuse

- Not adjusted properly.
- Not following manufacturer's recommendations for use, care, and maintenance.
- Suspension syndrome, due to hanging in harness instead of sitting in harness.

Types

- Class I. *Ladder belt*
 - Harness that fastens around the waist, thighs, or under buttocks.
 - Designed to be used for emergency escapes with one-person loads.
- Class II.
 - Harness that fastens around the waist and thighs or under buttocks.
 - Designed for rescue where two-person loads can be encountered.
- Class III.
 - Harness that fastens around the waist, thighs, or under the buttocks and over the shoulders.
 - Can be a one- or two-piece model depending upon manufacturer.
 - Designed for rescue where two-person loads can be encountered.
- Victim harness.
 - Harness that attaches quickly and securely around the waist and thighs or under buttocks no matter where or how the victim is positioned.
 - The design allows the harness to be put on without the victim having to step into the harness.

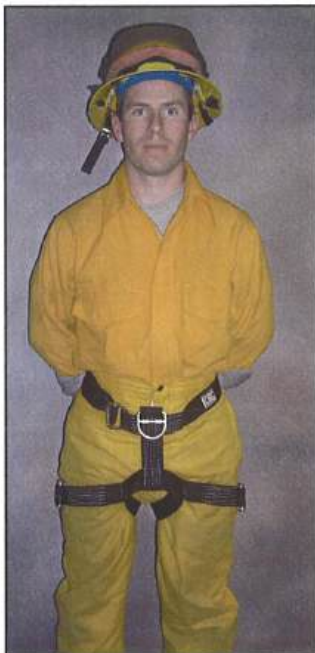

Figure 2-11: Class II Harness



Figure 2-12: Class III Harness



Figure 2-13: Victim Harness

Construction

- Meets NFPA 1983 Standard on Fire Service Life Safety Rope and System Components.

Size/Dimension

- Varies depending upon manufacturer.

Inspection/Maintenance

- Inspection.
 - Same as load release device, plus pay particular attention to frayed stitching.
- Care and storage.
 - Same as rope, plus:
 - Do not drop or throw.
 - Follow manufacturer's instructions.
- Cleaning.
 - Hand wash; do not put in a washing machine.
- Retiring/removing from service.
 - When subjected to shock loads, fall loads, or abuse outside of normal limits.
- The fall protection industry recommends a service life for a harness or belt of 2-3 years.
 - The fall protection industry recommends a shelf life of 7 years.

Carabiner

Drop from 6' → 0.5' onto concrete.

Components

- Spine.
- Lock.
- Gate.
- Hinge.

Use

- Load-bearing metal connectors that link the elements of the rescue system.
- Create friction.

Misuse

- Side loading.
- Using a carabiner as a brake bar.
- Dropping or throwing.
- Locking nut after loading system.
- Unlocking when under load.

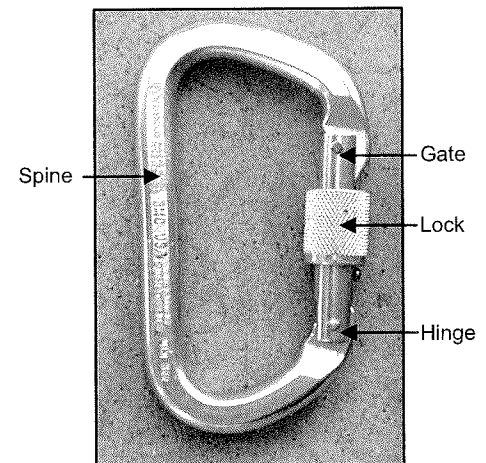

Figure 2-14: Components

Types

- Oval.
- D-shape.
- Modified D.
- Nonlocking.
- Locking.
- Auto locking.

Construction

- Steel or aluminum.
- NFPA 1983 Standard on Fire Service Life Safety Rope and System Components "General Use" compliant.
 - Major axis breaking strength.
 - Gate closed of at least 40 kN (8,992 LBF).

Size/Dimension

- Varies depending upon use.
- Rescue use/applications require NFPA 1983 Standard on Fire Service Life Safety Rope and System Components general use compliance.

Inspection/Maintenance

- Inspection.
 - Dents.
 - Burrs.
 - Rust/corrosion.
 - Cracks and gouges.
 - Proper gate and lock function.
- Care and storage.
 - Remove burrs and sharp edges with small file or emery cloth.
- Cleaning.
 - Clean with water and wipe dry with cloth.
- Retiring/removing from service.
 - Deformed.
 - Gate fails to lock or sticks.
 - Cracked or gouged.
 - Dropped from head height.

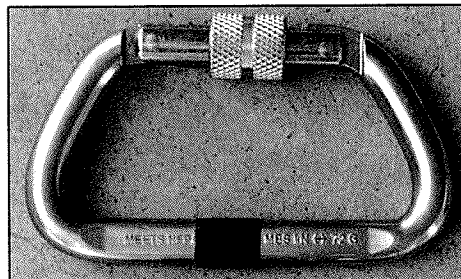

Figure 2-15: Locking D

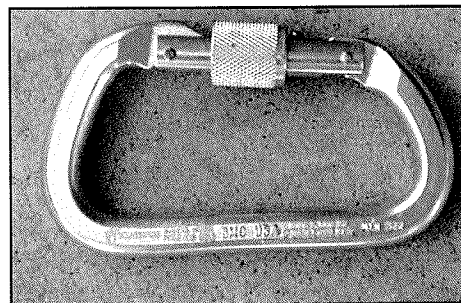

Figure 2-16: Locking Modified D



Figure 2-17: NFPA Label

Brake Bar Rack

min. 4 bars, including top bar

Components

- An inverted U-shaped frame with a welded eye at one end and a nut on the other.
- A series of bars with a hole in one end enabling the bars to slide along the long side of the frame.

Use

- Create friction.
 - Rappel.
 - Lower.
- Advantages.
 - Adjustable friction.
 - Without interruption to lowering or rappel.
 - Does not twist rope.
- Disadvantages.
 - Complex to reeve.
 - Can be side-loaded.
 - Length can create difficulties at low point of departure.

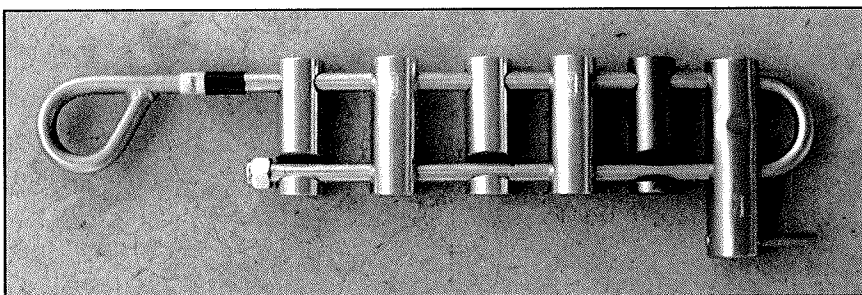

Figure 2-18: Brake Bar Rack with Tie-off Bar

Misuse

- Rigging the rope onto the bars the wrong way.

Types

- Standard racks with and without a "tie-off bar."
 - Racks with 90° twist of eye.
- U-shaped racks.

Construction

- NFPA 1983 Standard on Fire Service Life Safety Rope and System Components compliant.
 - Minimum breaking strength of 22 kN (4,946 LBF).
- Steel rack.
- Aluminum bars.
 - Advantages.
 - Provides more friction.
 - Lightweight.
 - Disadvantages.

- Streaks rope.
- Steel bars.
 - Advantages.
 - No streaking of rope.
 - Disadvantages.
 - Provides less friction.
 - Heavier than aluminum.

Size/Dimension

- Varies, depending upon use and manufacturer.

Inspection/Maintenance

- Inspection.
 - Secure nut.
 - Bent rack.
 - Worn bars.
 - Cracks.
 - Burrs and/or sharp edges.
- Care and storage.
 - Remove burrs and sharp edges with small file or emery cloth.
- Cleaning.
 - Wipe clean with cloth.
- Retiring/removing from service.
 - Deformed or cracked.
 - When 15% or more of the original diameter of aluminum bars is worn away.
 - Dropped from more than head height.

Figure Eight Plate with Ears

Components

- Small ring (lower one) for clipping into a seat harness with a carabiner.
- Large ring (top one) through which rope passes to create friction.
- "Ears" or projections fabricated into the large ring.

Use

- Create friction.
 - Rappel.



Figure 2-19: Figure Eight Plate with Ears

- Lower.
- Advantages.
 - Easy to reeve.
- Disadvantage.
 - Limited friction.
 - Once loaded, cannot add more friction to the device.

Misuse

- Using improper sized descender for the diameter of the rope being used.
- Used to gather equipment.

Types

- Conventional (without ears).
- Descender with ears.

Construction

- NFPA 1983 Standard on Fire Service Life Safety Rope and System Components compliant.
 - Minimum breaking strength of 22 kN (4,946 LBF).
- Aluminum.
- Steel.

Size/Dimension

- Varies, depending upon use and manufacturer.

Inspection/Maintenance

- Inspection.
 - Dents.
 - Cracks.
 - Sharp edges caused by rope wear.
 - Grooves caused by rope wear.
- Care and storage.
 - Remove burrs and sharp edges with small file or emery cloth.
 - Avoid dirty ropes.
 - Cause accelerated wear.
- Cleaning.
 - Wipe clean with cloth.
- Retiring/removing from service.
 - Deformed.
 - When 15% or more of the original diameter of aluminum bars is worn away.
 - Cracked.
 - Dropped from more than head height.

Rescue Pulley

Components

- Axle.
- Bearing.
- Sheave.
- Side plates or checks.

Use

- Change of direction.
- Mechanical advantage.
- Reduce friction.
- Tend prusiks (prusik minding pulley).

Misuse

- Side loading.
- Oversized/undersized rope.
- Attached with only one (1) side plate.
- Using wire/cable on rope pulley.

Types

- Light use (NFPA 1983 Standard on Fire Service Life Safety Rope and System Components).
- General use (NFPA 1983 Standard on Fire Service Life Safety Rope and System Components).
 - Prusik minding pulley.
 - Round pulley.
 - Confined space rescue.
 - Industrial/cable.

Construction

- Aluminum.
- Steel.
- Sealed ball bearing.
- Oilite® bronze bushing.
- NFPA 1983 Standard on Fire Service Life Safety Rope and System Components compliant.
 - Minimum breaking strength of 36 kN (8,093 LBF).

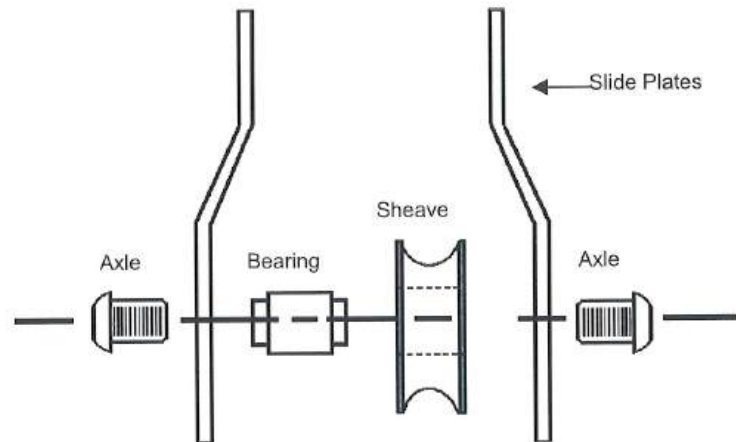

Figure 2-20: Rescue Pulley Components



Figure 2-21: Prusik Minding Pulley



Figure 2-22: Round Pulley

Arrow pt. to load

Size/Dimension

- Determined by sheave diameter.
 - 1½" to 4".

Inspection/Maintenance

- Inspection.
 - Proper movement of side plates and sheave.
 - Egg shaped attachment hole, which indicates if the pulley has been over stressed.
 - Tightness of nuts and/or bolts on end of axle.
- Care and storage.
 - Remove burrs and sharp edges with small file or emery cloth.
 - Do not lubricate bearings or bushings.
- Cleaning.
 - Clean with water and wipe dry with cloth.
- Retiring/removing from service.
 - Cracked side plates.
 - Frozen pulley sheaves.

Mechanical Grab Device

Components

- Shell.
- Cam.
- Pin.

Use

- Ascender.
- Haul cam.

Misuse

- Used as belay/safety brake.
- Placed on rope incorrectly.

Types

- Varies depending upon manufacturer.

Construction

- Aluminum or steel.
- Model specific to rope diameter.
- Strength per manufacturer.

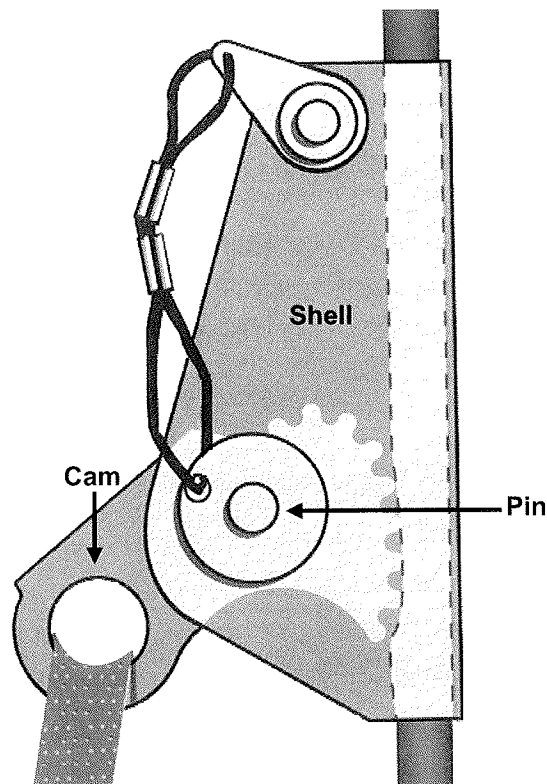

Figure 2-23: Ascender

Size/Dimension

- Varies, depending upon manufacturer.

Inspection/Maintenance

- Inspection.
 - Worn cam teeth.
 - Egg shaped holes for pin placement.
 - Cracks around holes for pin placement.
 - Worn cord, cable, or chain holding pin and cam to sleeve.
- Care and storage.
 - Store with components assembled.
- Cleaning.
 - Clean with water and wipe dry with cloth.
- Retiring/removing from service.
 - Sleeve or cam is cracked.
 - Sleeve is deformed.
 - Holes in the sleeve are worn enough to allow the pin to slip out.
 - Spring or other material holding cam and pin to sleeve is broken.
 - Dropped from more than head height.

Anchor Plate

Components

- Large opening for anchor point attachment.
- Multiple smaller openings for system hardware attachment.

Use

- Help organize anchor and system component rigging.

Misuse

- Using one side of the plate for both anchor system and component system rigging.

Types

- Attachment openings vary depending upon manufacturer.

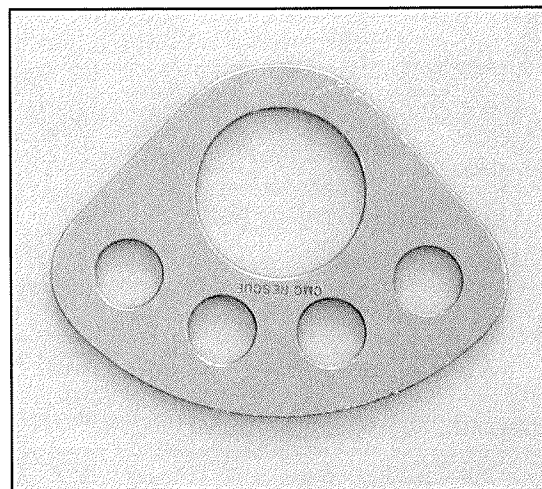

Figure 2-24: Anchor Plate

Construction

- Stamped or machined out of billet sheet aluminum.
- Stainless steel.
- NFPA Standard on Fire Service Life Safety Rope and System Components general use minimums.
 - Tensile strength of at least 36 kN (8,093 LBF).

Size/Dimension

- Varies, depending upon manufacturer.

Inspection/Maintenance

- Inspection.
 - Cracks.
 - Deformation.
 - Burrs.
- Care and storage.
 - Remove burrs and sharp edges with small file or emery cloth.
- Cleaning.
 - Clean with water and wipe dry with cloth.
- Retiring/removing from service.
 - Cracked.
 - Deformed.
 - Dropped from more than head height.

Edge Protection

Components

- Varies depending upon manufactured type and construction.

Use

- Protects rope and other system software from abrasion and sharp edges.

Misuse

- Not secured at departure edge.

Types

- Edge roller.
- Edge guard.

Construction

- Edge roller.
 - Aluminum wheels and frame.
 - Frames connect together in series.
- Edge guard.
 - Canvas.
 - Fire hose.
 - Plastic.

Size/Dimension

- Varies, depending upon type and manufacturer.

Inspection/Maintenance

- Edge roller inspection.
 - Tightness of any nuts and/or bolts.
 - Wear on rope contact points.
 - Moving parts should move smoothly.
- Edge guard inspection.
 - Excessive wear.
- Care and storage.
 - Per manufacturer's recommendations.
- Cleaning.
 - Clean with water and wipe dry with cloth.
- Retiring/removing from service.
 - Edge roller.
 - Rollers are bent, stuck, or otherwise broken, including bent or broken frame.
 - Edge guard.
 - Material worn through at rope contact points.

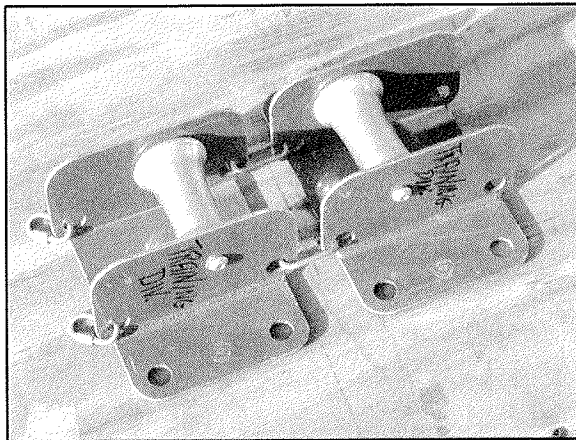

Figure 2-25: Edge Roller



Figure 2-26: Edge Guard

Chapter 3: Rescue Knots and Hitches

Scope: This chapter serves as an introduction to rescue knots and hitches.

Terminal Learning Objective (TLO): At the end of this chapter, the student will be able to identify and properly tie a small number of knots that perform a variety of functions.

Enabling Learning Objectives (ELO):

1. Define the qualities of a rescue knot
2. Define rope terminology
3. Describe the components of knots and hitches
4. Demonstrate how to tie the six required knots

Perhaps the most basic of skills for a rescuer is the ability to tie knots. Rescue knots are a key link to rope rescue systems. Rescue personnel must continually practice and develop knot-tying skills until they can tie knots properly in the most adverse of conditions. An improperly tied knot or the incorrect knot could result in system failure.

Although there are many options of knots to choose from, a rescue team should rely on a small number of knots that perform a variety of functions. Knots should be standardized so everyone on the team can readily identify and safety-check them.

In an effort to standardize terminology, this unit will attempt to use the current name for each knot, but acknowledges that there are many different names for the same knot. Oftentimes, a region or group will determine the standard term for a given area.

Knots should be untied or loosened before storing when practical. Knots that have been used to form permanent components such a prusik loops and stokes litter prerigs would not be practical to untie or loosen.

Qualities of a Rescue Knot

Five characteristics apply to any preferred rescue knot:

1. Easy to tie.
2. Easy to identify if tied correctly.
3. Relatively easy to untie after loading.
4. Minimally reduces the strength of the rope.
5. Won't work loose when not under a load.

Rope Terminology

- The **running end** of a rope is the part that "runs" away from the knot.
- The **working end** of a rope (also known as the loose end or bitter end) is the part used in forming a knot.
- The **standing part** of a rope is between the working end and the running end.

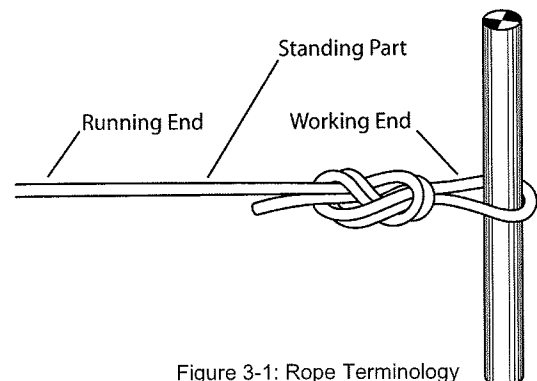

Figure 3-1: Rope Terminology

Components of Knots and Hitches

All knots and hitches can be tied or formed by combining these three components.

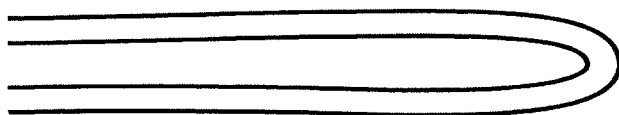

Figure 3-2:

A **bight** is formed by bending a rope back on itself while keeping the sides parallel.

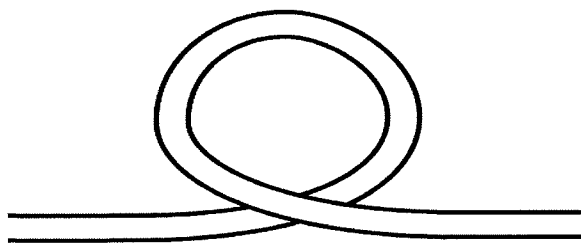

Figure 3-3:

A **loop** is formed by crossing one side of the bight over the other, keeping the sides parallel and in opposite directions.

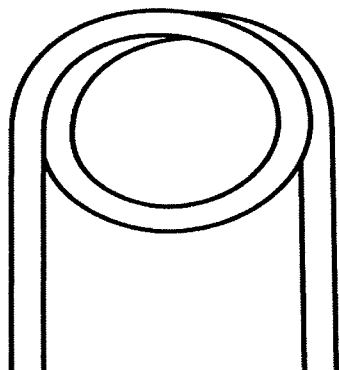

Figure 3-4: Round

A **round turn** is formed from a loop by continuing to cross one side of the loop all the way around an object to form a circle with the ends of the rope parallel as in a bight.

Hitches

Hitches can be used to temporarily secure objects. For example, securing equipment to haul aloft (a clove hitch and half hitches) or securing a victim to a rescue litter (round turn and two half hitches).

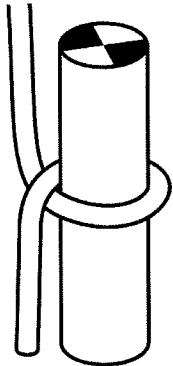

Figure 3-5: Half Hitch from the Loop

A **half hitch** can be formed from a loop that is wrapped around an object with one end crossing over the other and placed under tension.

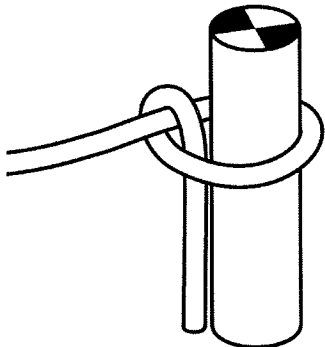

Figure 3-6: Half Hitch on the Loop

A **half hitch** can also be formed on the loop itself.

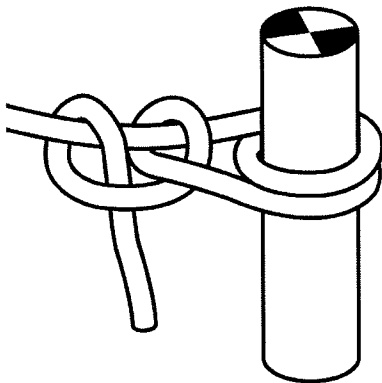

Figure 3-7: Round Turn and Two Half Hitches

A common application is a **round turn and two half hitches**. This combination allows the rescuer to increase tension on the line or webbing with the round turn and then to secure that tension with the two half hitches.

Knots

A **knot** is a combination of components: bights, loops, and round turns. The combination that is used, determines the specific knot that is constructed.

A **bending knot** (overhand bend, figure eight bend, double overhand bend) is used to tie rope or webbing into itself to form a continuous loop, or to join two lengths of material together to extend the length.

Proficiency in six knots is required for this course. These are the "need to know" or required knots for this class. Most low angle rescues can be performed with these knots. An additional six (6) knots have been identified as "nice to know" or optional knots. Instructors may add to the list depending on regional needs.

Terminology

All knots must be "dressed" and "set" tightly. "Dressing" a knot means ensuring that any twists or abnormalities are removed from the knot leaving it looking uniform. "Setting" a knot means pulling tension on all strands of the standing portion of the rope and on the tail left on either side of a knot. This removes any slack from the strands of the rope forming a knot, effectively "setting" the knot.

Tail Length

Tail length on knots will vary. **Minimum** tail length for the following materials shall be:

- Figure eight knots and bends in lifeline are 6".
- Double overhand on a bight in lifeline is 2".
- Overhand knots and bends in webbing are 2".
- Half hitches in webbing or rope are 2".
- Double overhand bend in prusik cordage is 1".

The curriculum for Low Angle Rope Rescue does not require that knots be backed up. Many regional rescue teams require that all knots shall be backed up with additional overhand knots formed with the tail of the rescue knot. In these instances, a longer tail will need to be left once the rescue knot is tied, dressed, and set to provide enough material to tie the back up knots.

Required Knots

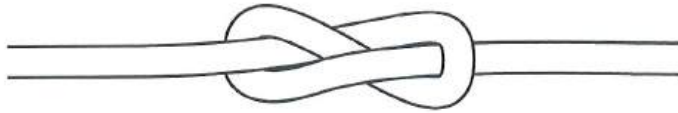

1. Figure Eight Stopper

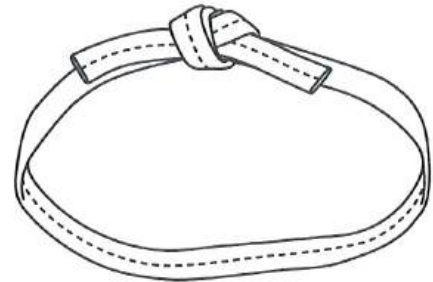

4. Overhand Bend



2. Figure Eight on a Bight

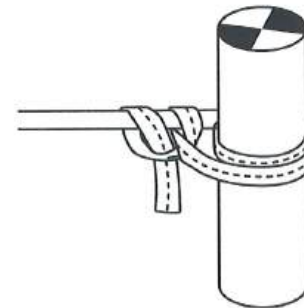

5. Round Turn with Two Half Hitches

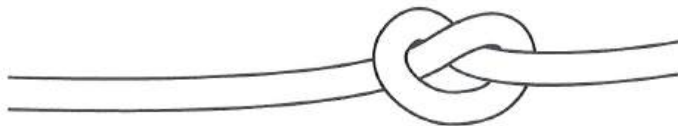

3. Overhand Knot

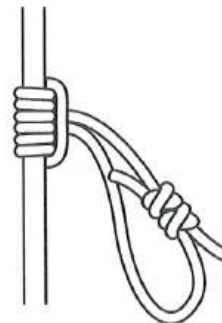

6. Three Wrap Prusik Hitch

Optional Knots

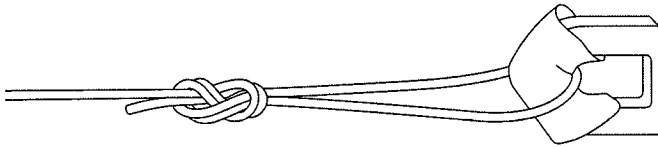

1. Figure Eight Follow Through

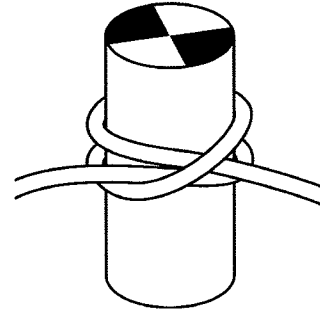

4. Clove Hitch



2. Figure Eight Bend

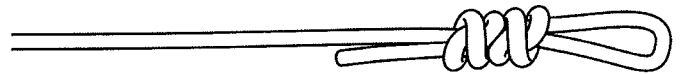

5. Double Overhand on a Bight



3. Double Overhand Bend

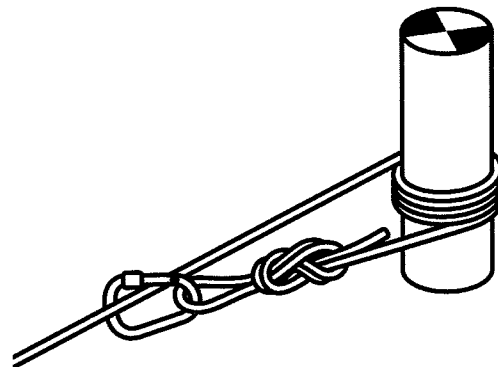

6. Tensionless Hitch

1. Figure Eight Stopper (Required)

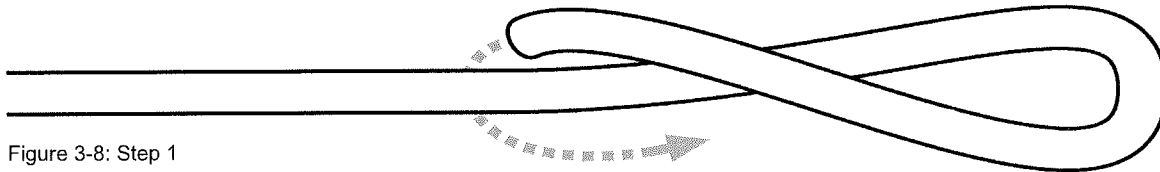

Figure 3-8: Step 1

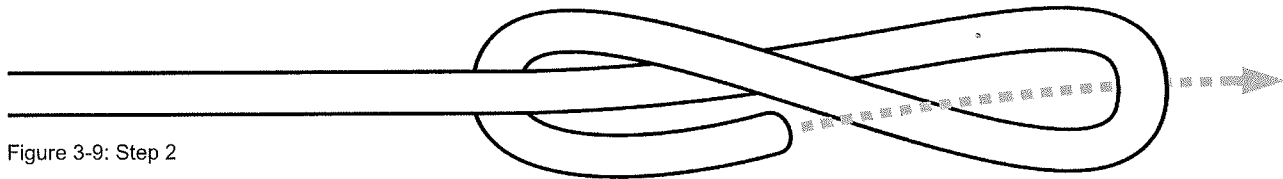

Figure 3-9: Step 2

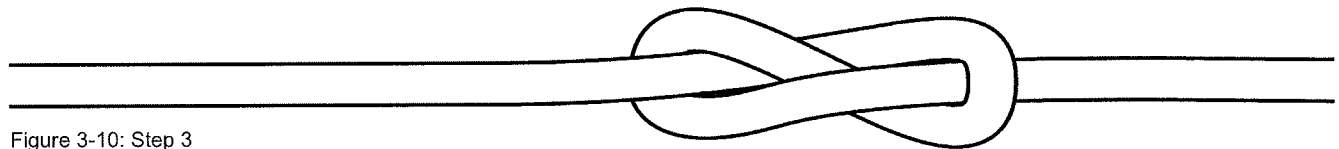

Figure 3-10: Step 3

Use

- Indicator of the end of the rope.
- Keep rope from pulling through a system or hands.
- Stop rope against a component in the system.
- Foundational knot for the rest of the family of eight knots

Specifics

- Tail length is dictated by use.
 - If used as an indicator of the end of the rope, leave enough rope to tie into a new system.
 - Generally 6".
- Dressed and set.

2. Figure Eight on a Bight (Required)

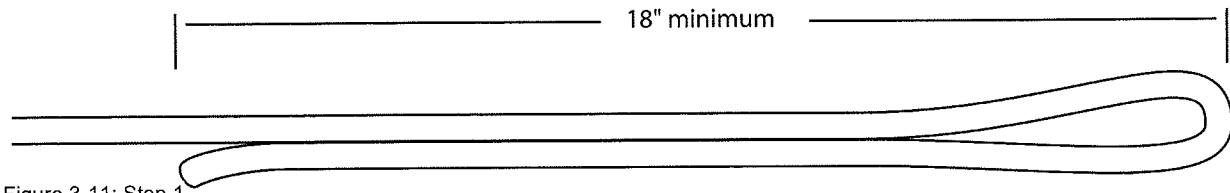

Figure 3-11: Step 1

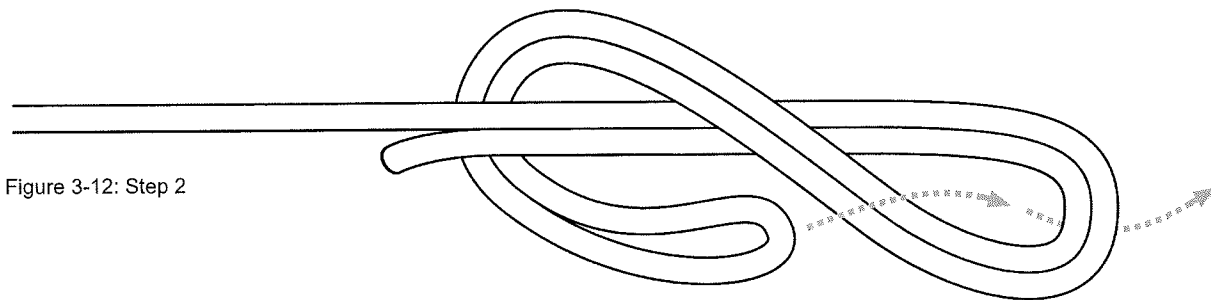

Figure 3-12: Step 2



Figure 3-13: Step 3

Use

- Form a secure loop in lifeline that can be attached to system components with a carabiner.
- Attach main lines and safety lines to:
 - Litters.
 - Anchors.
 - Rescuers.
 - Victims.

Specifics

- 6" tail (minimum).
- The length of the bight is determined by the use of the knot.
 - When attaching into a single point (i.e., pelvic harness), the bight should be 4".
 - When attaching into two points (i.e., pelvic and chest harness), the bight should be 6"-10".
 - When maximum length or availability of the line is needed, the bight should be kept 1"-2" in length.
- Dressed and set.

3. Overhand Knot (Required)

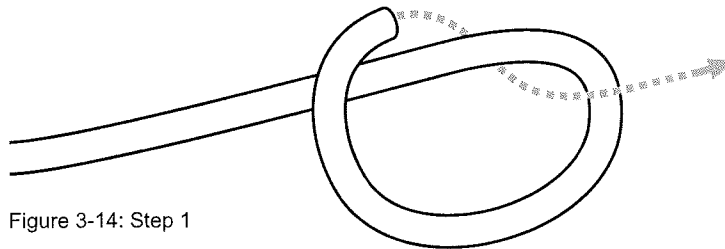

Figure 3-14: Step 1

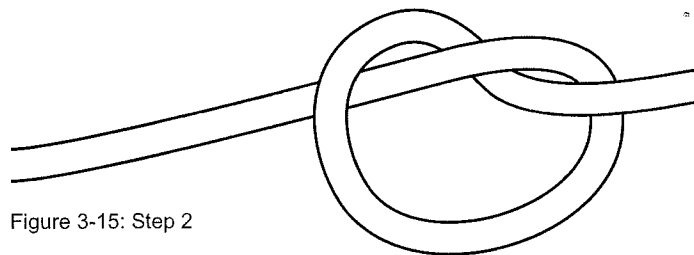

Figure 3-15: Step 2

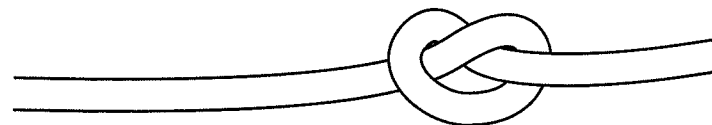

Figure 3-16: Step 3

Use

- Used on the tails of other knots (e.g., figure eight on a bight).
- Secure or take up loose or long ends in lifeline or webbing (e.g., excessive tail on a round turn with two half hitches).
- Can be used in place of half hitches.

Specifics

- 2" tails (minimum).
- Should be tied cleanly without twists in the webbing.
- Forms the foundation of the overhand bend.
- Dressed and set.

4. Overhand Bend (Required)

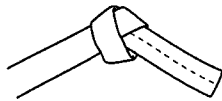

Figure 3-17: Step 1

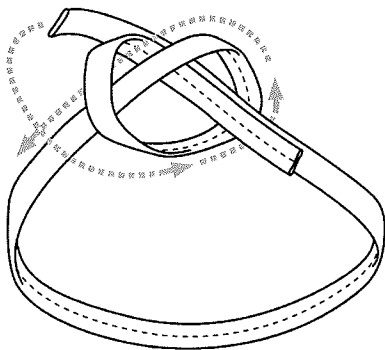

Figure 3-18: Step 2

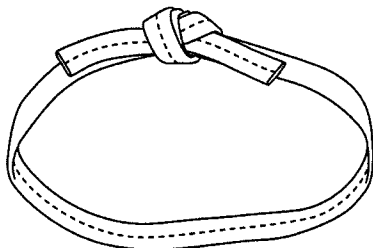

Figure 3-19: Step 3

Use

- Primary knot used in webbing to form a continuous loop.
- Join two pieces of webbing together to increase length.

Specifics

- 2" tails (minimum).
- Knots should be tied cleanly without twists in the webbing.
- Can be difficult to untie once loaded.
- Dressed and set.

5. Round Turn and Two Half Hitches (Required)

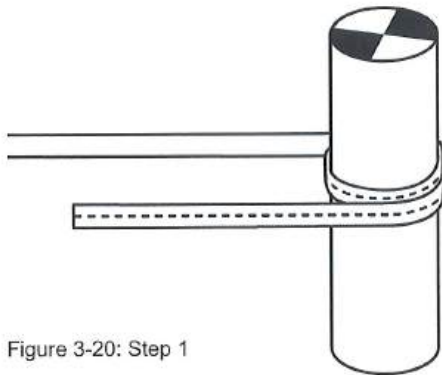

Figure 3-20: Step 1

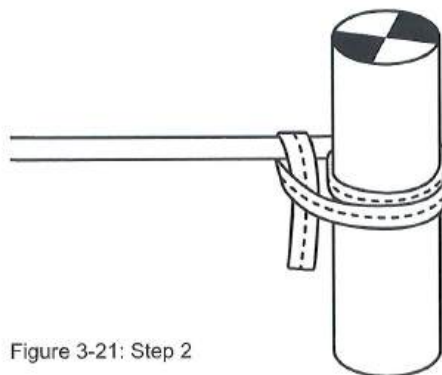

Figure 3-21: Step 2

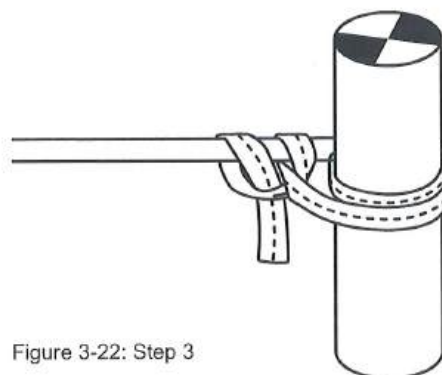

Figure 3-22: Step 3

Use

- Secure webbing or lifeline to an object.
 - Rescue litter.
 - Ladder rung.
 - Picket.

Specifics

- 2" tails (minimum).
- Should be tied cleanly without twists in webbing.
- Some rescue teams substitute two overhand knots for the two half hitches.
- Dressed and set.

6. Three Wrap Prusik Hitch (Required)

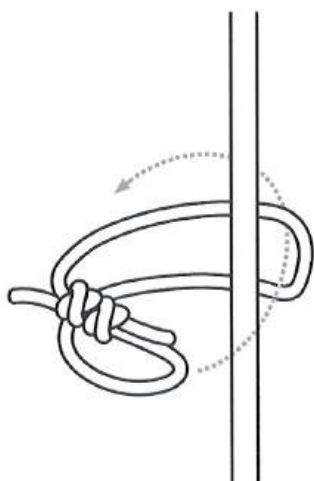

Figure 3-23: Step 1

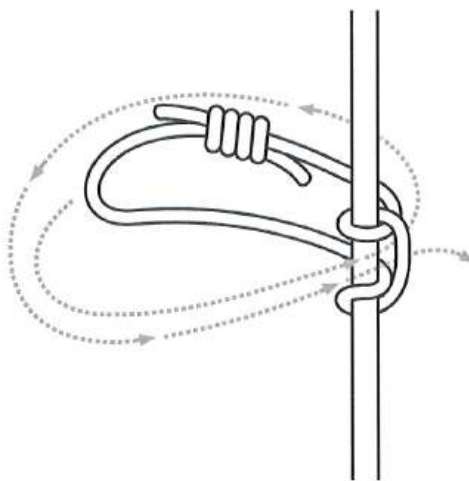

Figure 3-24: Step 2

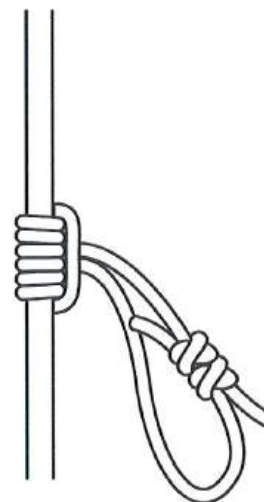

Figure 3-25: Step 3

Use

- Attach a prusik loop to a lifeline, forming a hauling, ratchet, or braking cam.

Specifics

- Use prusik loop made from 8mm cordage.
- The double overhand bend used to form the prusik loop should be positioned so that it does not interfere with the clipping point of the carabiner.
- The wraps of the prusik should be even and smooth.
- Some rescue teams utilize the "quick release" variation of the three-wrap prusik hitch.
 - Double overhand bend is positioned over the wraps of the prusik hitch.
- Contact the lifeline manufacturer to identify compatible cordage for the specific lifeline.
- Dressed and set.

1. Figure Eight Follow Through (Optional)

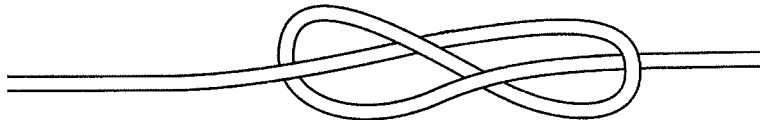

Figure 3-26: Step 1

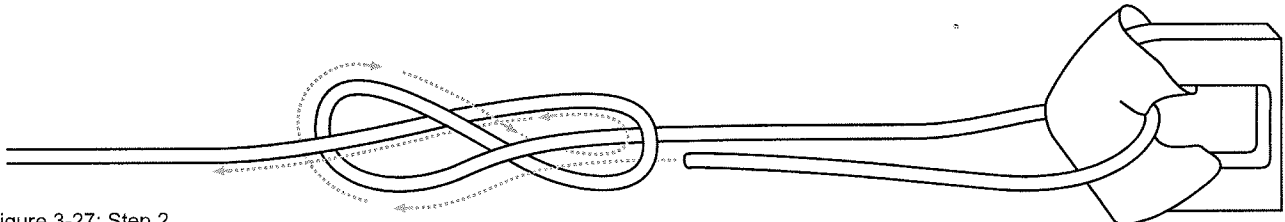
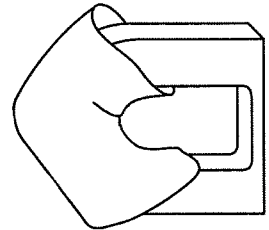

Figure 3-27: Step 2

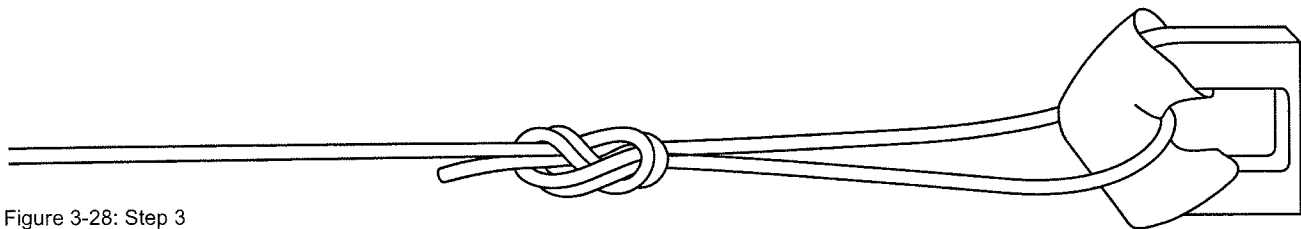

Figure 3-28: Step 3

Use

- Secure lifeline around an object such as a tree.
- Secure lifeline through a "trussed" anchor such as a closed tow hook on a fire engine.

Specifics

- 6" tail (minimum).
- Chaffing protection may be needed.
- Difficult to untie after loading.
- Dressed and set.

2. Figure Eight Bend (Optional)

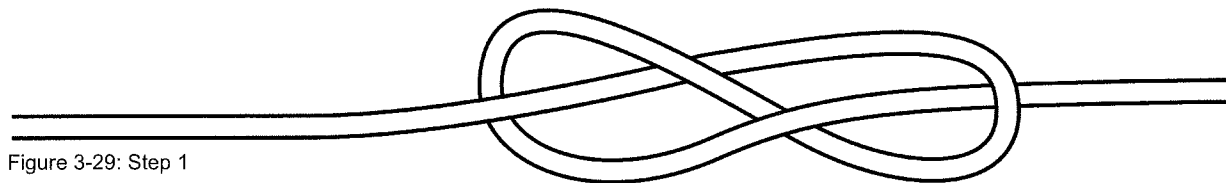

Figure 3-29: Step 1

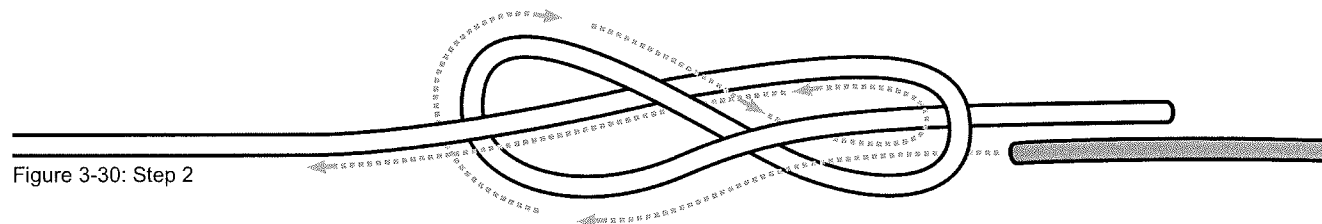

Figure 3-30: Step 2

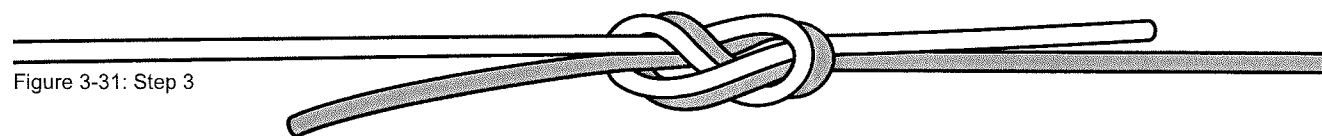

Figure 3-31: Step 3

Use

- Join two lifelines of the same diameter together.
- Tie one length of lifeline into a loop.

Specifics

- 6" tail (minimum).
- Difficult to untie after loading.
- Dressed and set.

3. Double Overhand Bend (Optional)

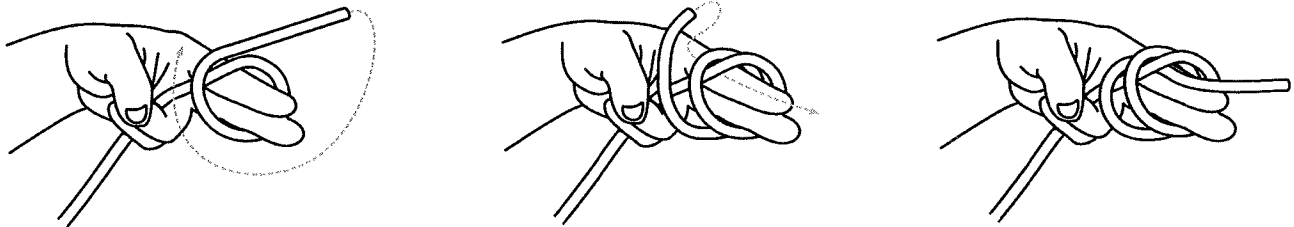

Figure 3-32

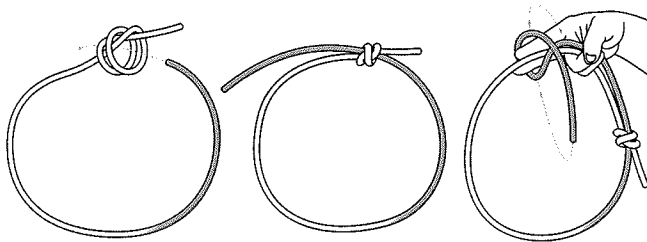

Figure 3-33

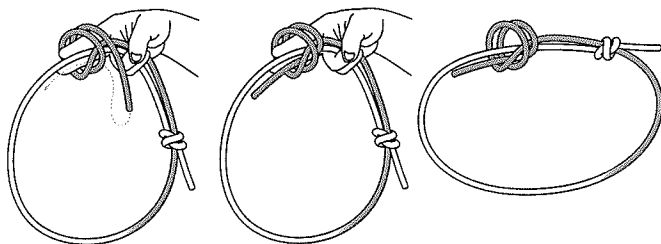

Figure 3-34



Figure 3-35

Use

- Tie two equal diameter ropes ends together.
- Preferred knot for tying prusik loops.

Specifics

- 1" tails (minimum).
- When tied correctly, the tail of each rope should end up on the side of the knot opposite the side it entered.
- The two turns from each half of the knot should lie flat against one another on one face of the knot and appear as a double X on the other side.
- Difficult to untie once loaded.
 - It is for this reason that once tied, prusik loops are not generally untied until damaged or retired.
- Dressed and set.

4. Clove Hitch (Optional)

Method 1: Slid Over the Open End of an Anchor

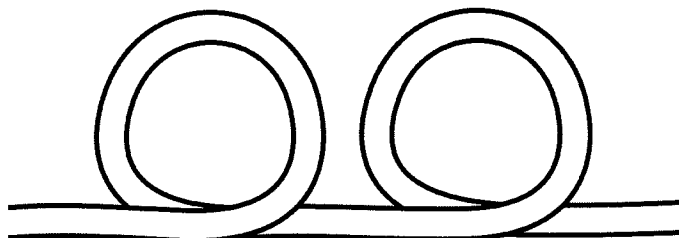

Figure 3-36: Step 1

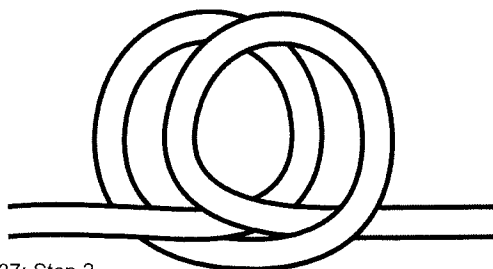

Figure 3-37: Step 2

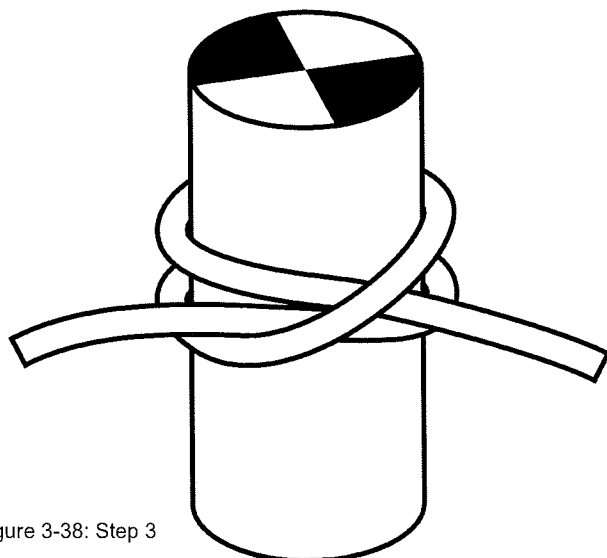

Figure 3-38: Step 3

Use

- Secure webbing or lifeline to a round, nontrussed anchor.
 - Picket.
 - Bullard.
- Used when the hitch can be slipped over one end of an anchor.

Specific

- 4" tail (minimum).
- Often backed up with one overhand knot or two half hitches.
- Dressed and set.

Method 2: Tied Around a Trussed Anchor

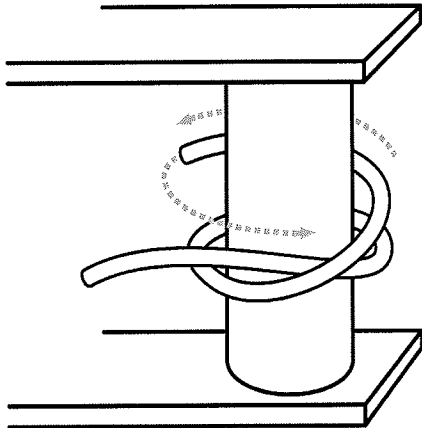

Figure 3-39: Step 1

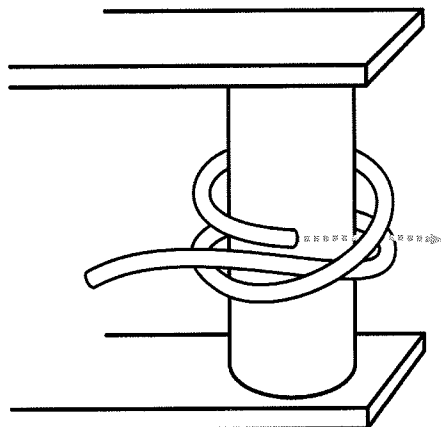

Figure 3-40: Step 2

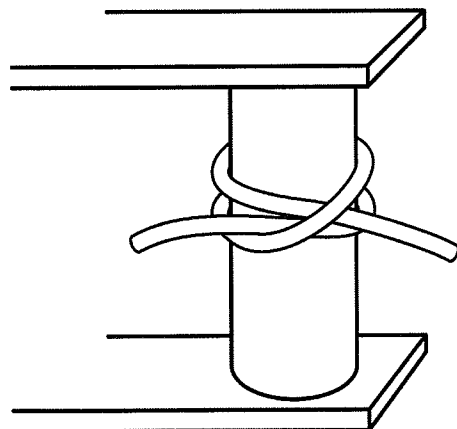

Figure 3-41: Step 3

Use

- Secure webbing or lifeline to a round, trussed anchor.
 - Litter rail.
 - Ladder rung.
 - Tree.
- Used when the hitch *cannot* be slipped over one end of an object.

Specifics

- 4" tail (minimum).
- Often backed up with one overhand knot or two half hitches.
- Dressed and set.

5. Double Overhand on a Bight (Optional)

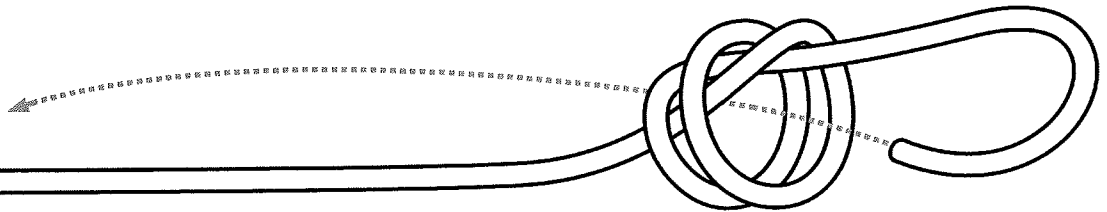

Figure 3-42: Step 1

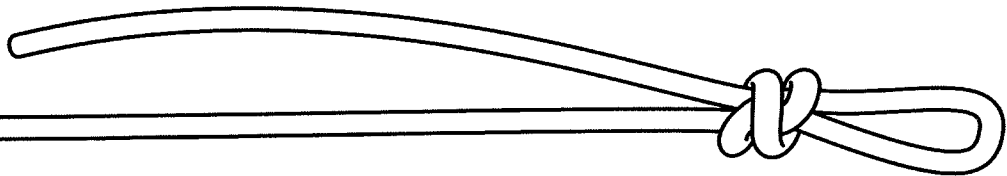

Figure 3-43: Step 2

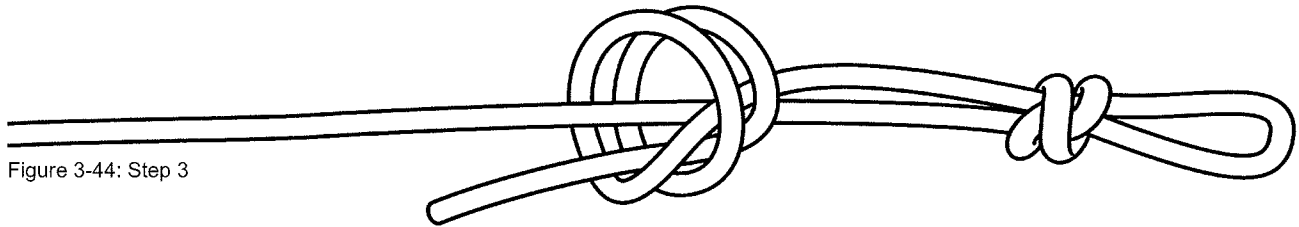

Figure 3-44: Step 3

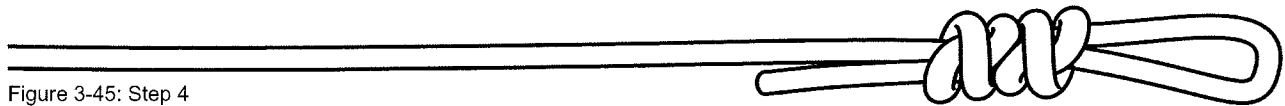

Figure 3-45: Step 4

Use

- Provide permanent bight or loop at the end of a rope or lifeline.
- Commonly used to replace the figure eight on a bight at the ends of prerigs.

Specifics

- 2" tail minimum.
- Once loaded, will not come undone.
- Very difficult to untie.
- Dressed and set.

6. Tensionless Hitch (Optional)

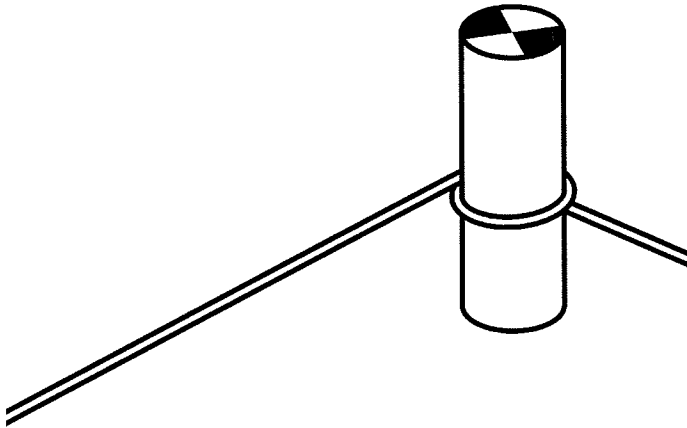

Figure 3-46: Step 1

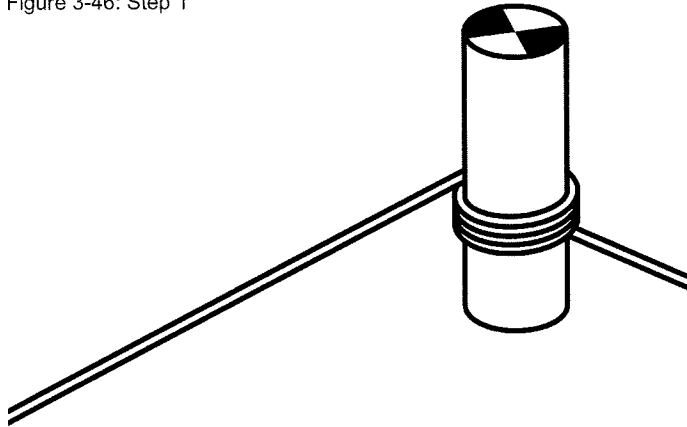

Figure 3-47: Step 2

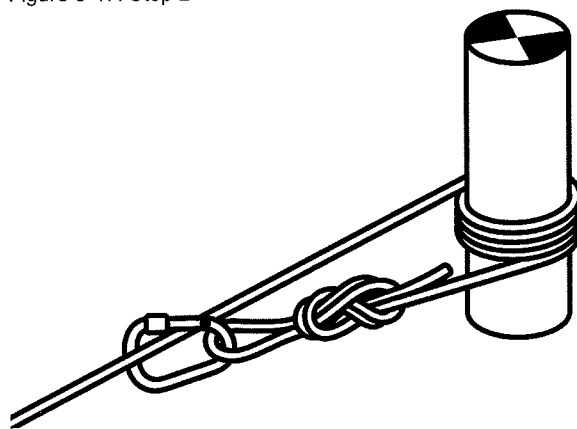

Figure 3-48: Step 3

Use

- Simple method to anchor a rope to a round anchor point.

Specifics

- Derives its name from the fact that the standing end of the lifeline does not have any tension in it when the working end is pulled on.
- Can preserve up to 100% of the strength of the lifeline.
- The number of wraps depends on the smoothness of the anchor.
 - The smoother the surface, the more wraps that will be needed.
 - Between 4-6 wraps.
- Using a round anchor less than 4" in diameter will result in a reduction in the strength of the lifeline.
- The lifeline is tied to the standing end of the lifeline as a safety measure using an overhand knot or secured with a carabiner.
- While this is an extremely strong way to anchor a lifeline, it can use a significant portion of the length of lifeline.
 - This shortening of available lifeline length must be considered before this anchor is used in a system.
- Dressed and set.

Chapter 4: Anchor Systems

Scope: This chapter serves as an introduction to anchor systems.

Terminal Learning Objective (TLO): At the end of this chapter, the student will be aware of anchor selection and anchor system construction.

Enabling Learning Objectives (ELO):

1. Describe a personal fall arrest system
2. Describe considerations when selecting anchors
3. Describe the types of anchors
4. Demonstrate how to form a single loop, double loop, locking girth hitch (lark's foot)
5. Demonstrate how to form a single and double loop basket sling (three bight)
6. Demonstrate how to form a single and multi-loop anchor sling
7. Demonstrate how to form a wrap three pull two anchor sling
8. Demonstrate how to construct a two-point/three-point self-adjusting anchor system
9. Demonstrate how to construct a tagged anchor system
10. Demonstrate how to construct a 1-1-1 inline and triangle windlass
11. Demonstrate describe sling anchor attachments: pretied
12. Demonstrate describe single sling anchor attachments: open
13. Demonstrate describe multi-point self-adjusting anchor systems
14. Demonstrate describe windlassed picket systems

An anchor (also called an anchor point) is a stationary object capable of supporting the load attached to it. An anchor system is the rope, slings, and hardware used to attach a load to the anchor, and includes the anchor. The result of an inadequate anchor or anchor system is failure of the system. Therefore anchor selection and anchor system construction are fundamental skills for the rescuer.

California Code of Regulations, Title 8, Section 1670

Personal Fall Arrest Systems

This standard requires that anchors be capable of supporting at least 5,000 pounds per employee attached or must be designed, installed, and used as part of a complete fall arrest system that maintains a safety factor of at least two and used under the supervision of a qualified person.

The systems described in this manual have been tested and found to comply with this standard. However, the user is responsible for ensuring all components of the system used are strong enough for their application.

Considerations When Selecting Anchors

When selecting an anchor several factors must be considered:

- How much force will the anchor need to be able to hold?
- What direction will the pull or force come from?
 - A "nondirectional anchor" will withstand a pull from any direction.

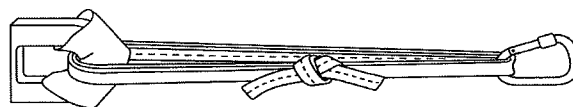

Figure 4-1: Nondirectional Anchor

- A "directional anchor" will fail if the load shifts to an unintended direction of pull.
- Is there an adequate and safe working distance between the anchor, anchor system, and edge?
- Does the anchor need to be padded to protect the anchor sling material from sharp edges, excessive heat, or caustic materials?

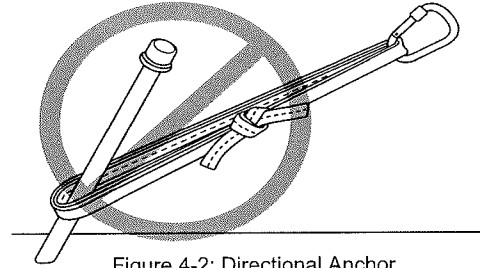

Figure 4-2: Directional Anchor

Types of Anchors

Natural Anchors

- Large living trees or solid rock.

Manufactured Anchors

Vehicles

- Potential anchor point
 - Preinstalled connect point.
- Have solid points to connect to:
 - Wheels.
 - Rear exterior dual preferred.
- Mitigate excessive heat and sharp edge conditions.
- Turn off engine.
 - Remove key if possible.
 - Tag out (sign on steering wheel).
- Set brake and chock wheels.
 - Should not move vehicle during rescue operation.
 - Light vehicles (pick-ups and other passenger types) may not be adequate.

Structural Components

- Utilize major structural components.
- Utilize well-established anchors on large machinery and equipment.
- Inspect potential anchors for rust, corrosion, weathering, and quality of installation.
- Consider spanning windows and door openings to create anchors.

Pickets

- Offer a portable, drivable set of anchors if the soil is available and adequate.
- Must be driven at an angle (approximately 15°) away from the load.
- The lower the windlass (if utilized) the stronger the system will be.
- Check for underground utilities before driving.

Others

There are several other types of manufactured anchors that will not be covered in this class. These range from setting large and permanent anchor bolts in holes drilled in concrete in heavy rescue operations, to inserting very small and temporary anchoring devices unique to mountain rescue operations. These are specialized pieces of equipment that require additional training. This course will deal with anchor options that are more common to most low angle rescue operations.

Sling Anchor Attachments: Pretied

To perform low angle rope rescue quickly and efficiently, anchors must be placed in service rapidly. Pretied slings can be used to accomplish this; eliminating the time taken to tie knots at the scene. Pretied sling attachments are formed with a length of webbing or lifeline that is tied into itself to create a continuous loop. Webbing is commonly pretied with an overhand bend. Lifeline is commonly pretied with a figure eight bend or a double overhand bend.

Advantages

- Quick to form around anchors.
- Easy to relocate.
- Quick to remove from anchors.
- Easy to increase the sling's strength by doubling the loop.

Disadvantages

- Unable to be adjusted to larger anchors.
- May be weakened by changes in the direction of pull.

Forming the Double Loop

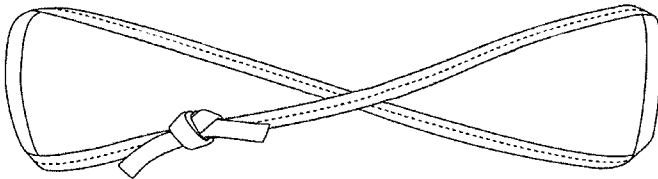

Figure 4-3: Step 1

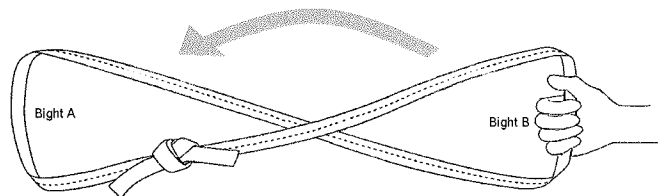

Figure 4-4: Step 2

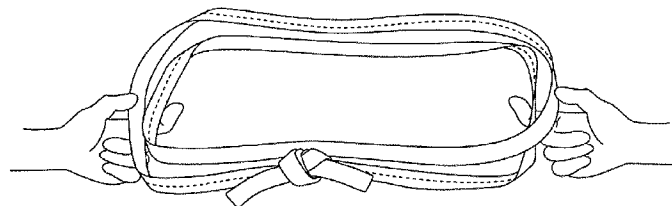

Figure 4-5: Step 3

- 1) Form a large, single loop in the shape of a figure eight.
- 2) Move Bight B on top of Bight A.
- 3) Pull hands apart to form the double loop.

Single Loop Girth Hitch (Lark's Foot)

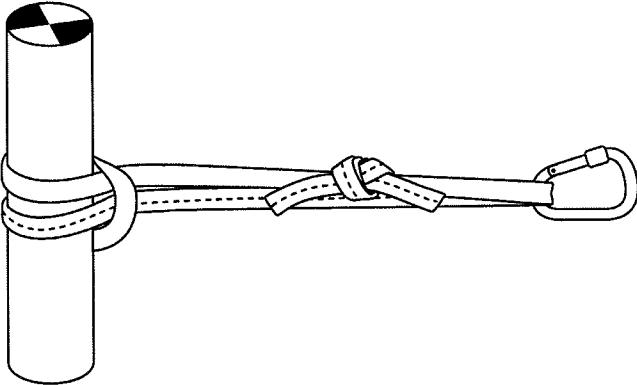

Figure 4-6: Single Loop Girth Hitch (Lark's Foot)

- Rating.
 - General use when formed with lifeline.
 - Light use when formed with webbing.
 - Working position, single person load only.
- Advantages.
 - Holds position on anchor reasonably well.
- Disadvantages.
 - Overloading may cause the sling to slide against itself, generating enough heat to damage it.

Double Loop Girth Hitch (Lark's Foot)

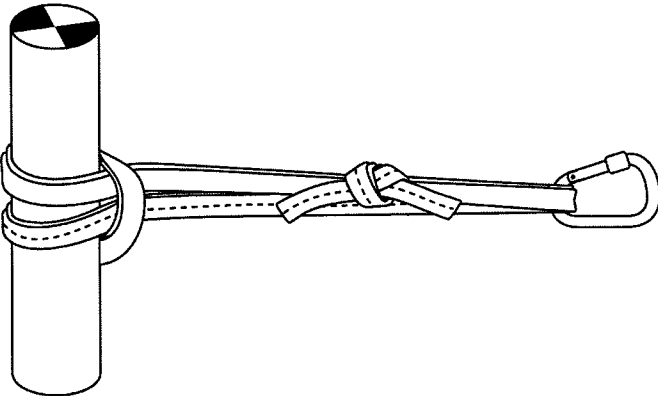

Figure 4-7: Double Loop Girth Hitch (Lark's Foot)

- Rating.
 - General use when formed with lifeline or webbing.
- Advantages.
 - Holds position on anchor reasonably well.
 - Significantly stronger than the single loop girth hitch.
- Disadvantages.
 - Overloading may cause the sling to slide against itself, generating enough heat to damage it.

Locking Girth Hitch (Lark's Foot)

This hitch can be used to "finish" a single or double loop girth hitch.

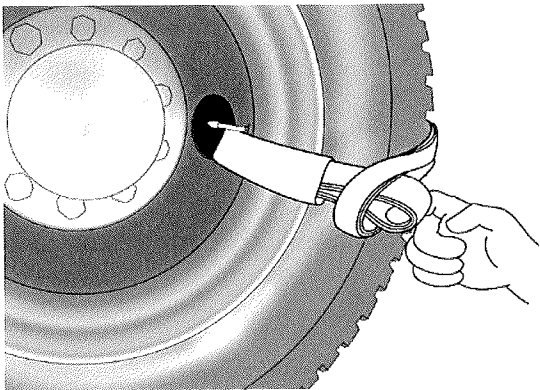

Figure 4-8: Step 1

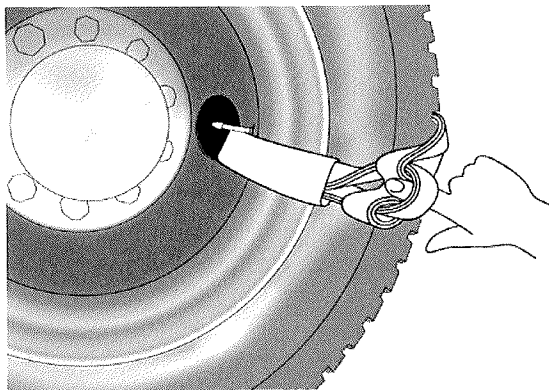

Figure 4-9: Step 2

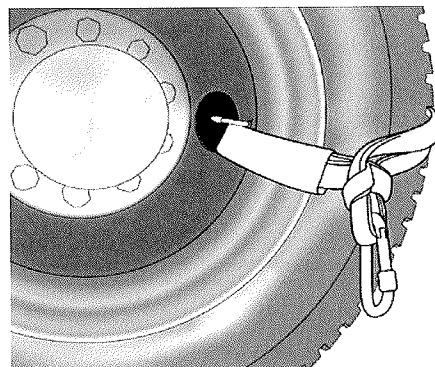

Figure 4-10: Locking Double Loop Girth Hitch (Lark's Foot)

- ❑ Rating.
 - General use when formed with:
 - Single loop girth hitch with lifeline.
 - Double loop girth hitch with lifeline or webbing.
 - Light use when formed with a single loop girth hitch with webbing.
- ❑ Advantages.
 - Holds position on anchor extremely well.
- ❑ Disadvantages.
 - Overloading may cause the sling to slide against itself, generating enough heat to damage it.

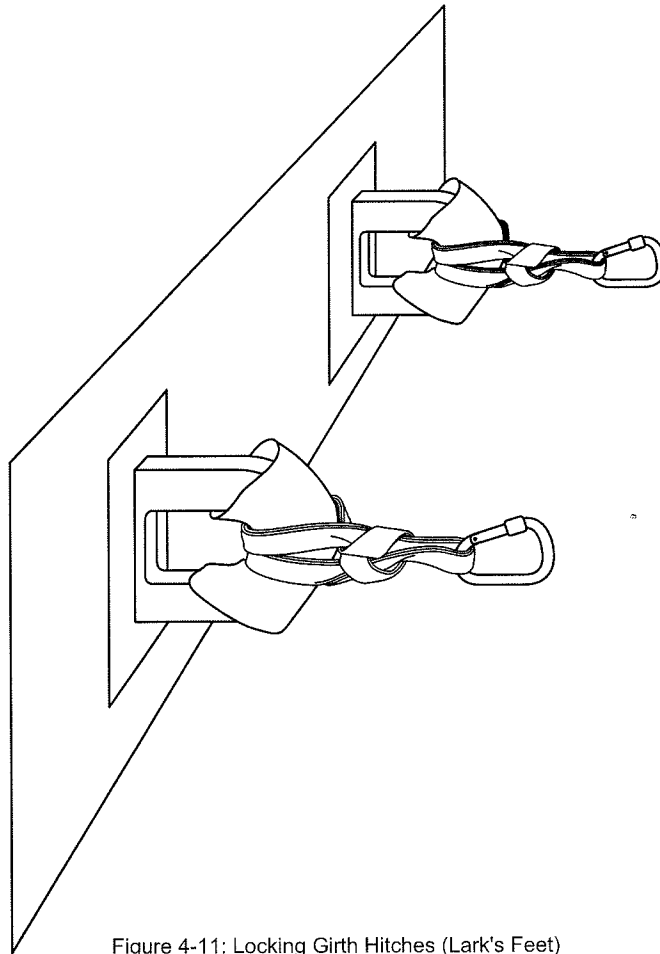

Figure 4-11: Locking Girth Hitches (Lark's Feet)

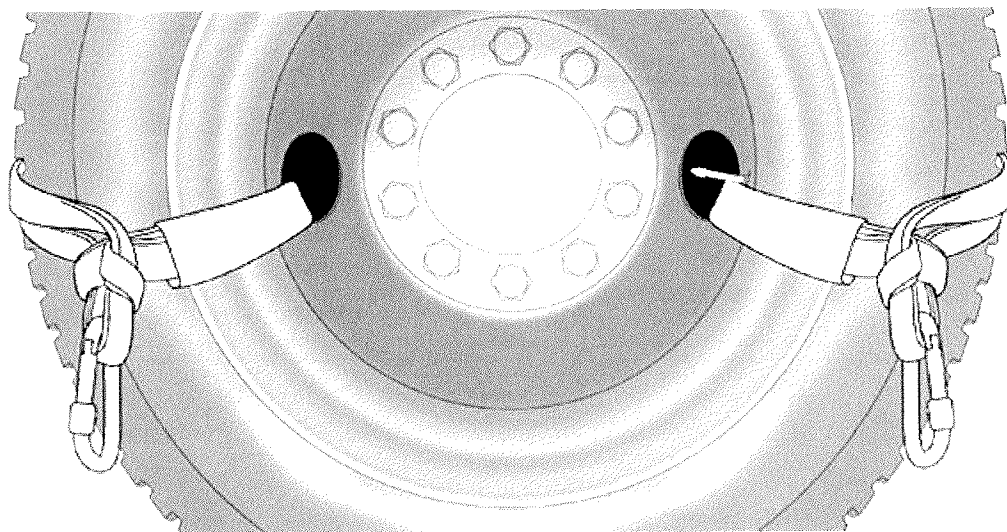

Figure 4-12: Locking Girth Hitches (Lark's Feet) Shown Tandem on a Wheel

Single Loop Basket Sling (Three Bight)

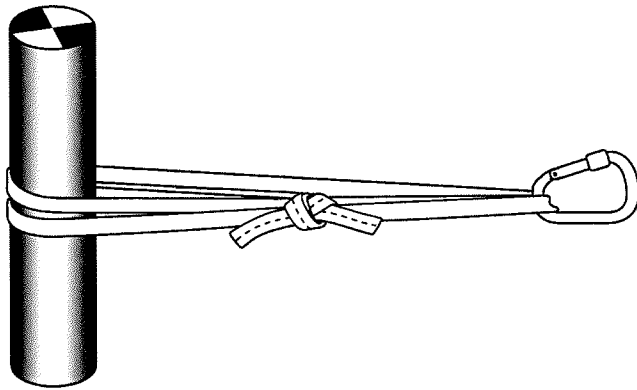

Figure 4-13: Single Loop Basket Sling (Three Bight)

- Rating.
 - General use when formed with lifeline or webbing.
- Advantages.
 - Does not slide against itself, so no heat generation.
- Disadvantages.
 - When the length of the sling is too short, it will tri-load the connecting carabiner.
 - This significantly decreases the strength of the carabiner.
 - Does not hold position on anchor unless loaded.

Double Loop Basket Sling (Three Bight)

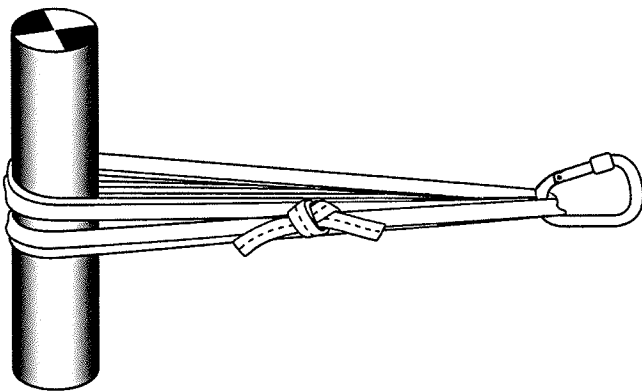

Figure 4-14: Double Loop Basket Sling (Three Bight)

- Rating.
 - General use when formed with lifeline or webbing.
- Advantages.
 - Significantly stronger than a single loop basket sling.
- Disadvantages.
 - When the length of the sling is too short, it will tri-load the connecting carabiner.
 - This significantly decreases the strength of the carabiner.
 - Does not hold position on anchor unless loaded.

Single Sling Anchor Attachments: Open

When pre-established anchors are not available and anchors of unknown size are used, it may be necessary to use open slings. Open slings are lengths of webbing or lifeline that are left untied until needed.

Open sling attachments are formed by wrapping a length of webbing or lifeline around an anchor and then tying it into itself. Webbing is commonly tied with an overhand bend. Lifeline is commonly tied with a figure eight bend or a double overhand bend.

Advantages

- Can be lengthened for larger anchors by tying slings together.
- Can be made stronger with multiple wraps.
- Can be adjusted more loosely or tightly by changing the length of the knot tail.
- Can adjust to changes of direction without losing strength.

Disadvantages

- Slow to form around anchors.
- Difficult to relocate (requires untying and retying a knot).
- Slow to remove from an anchor.
- Do not provide a stationary directional anchor point.

Types of Single Sling Attachments: Open

Single Loop

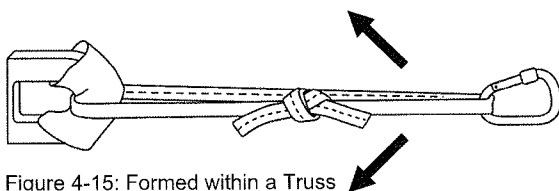

Figure 4-15: Formed within a Truss

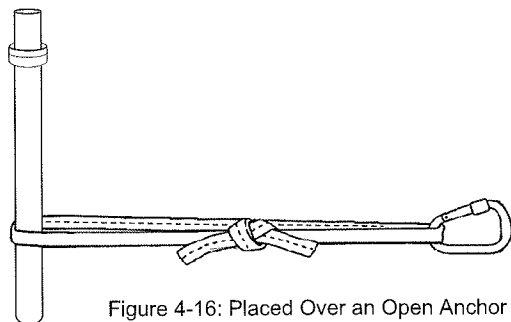

Figure 4-16: Placed Over an Open Anchor

- Rating.
 - General use when formed with lifeline.
 - Light use when formed with webbing.
 - Working position, single person load only.
- Advantages.
 - Less sling material required.
- Disadvantages.
 - Weaker than other slings of similar material.
 - Does not hold position on anchor unless loaded.

Multi-loop

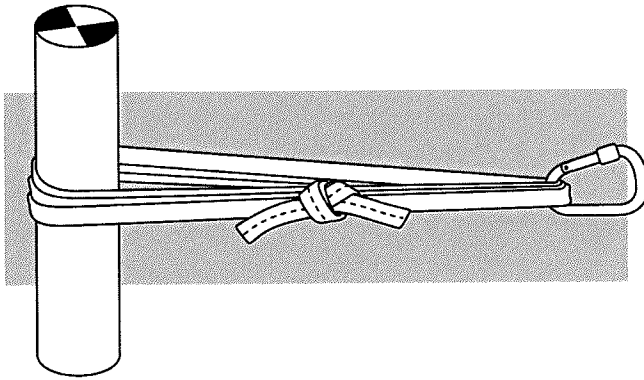

Figure 4-17: Multi-loop

- Rating.
 - General use when formed with lifeline or webbing.
- Advantages.
 - Significantly stronger than single loop.
 - Generally stronger than most open and pre-tied slings.
- Disadvantages.
 - Does not hold position on anchor unless loaded.
 - Requires longer lengths of material to form.

Wrap Three Pull Two

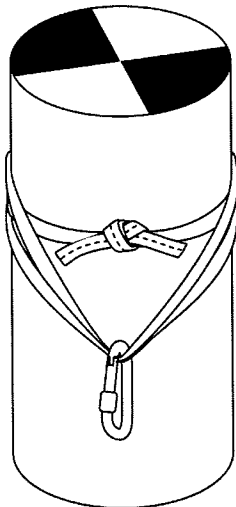

Figure 4-18: Wrap Three Pull Two

- Rating.
 - General use when formed with lifeline or webbing.
- Advantages.
 - Generally stronger than most open and pre-tied slings.
 - Holds position on anchor without being loaded.
 - Easy to untie if the knot is positioned as shown.
- Disadvantages.
 - Requires longer lengths of material to form.
 - Most complex to form and position.
 - Slowest of open slings to form.

Multi-Point Self-adjusting Anchor Systems

Situations will arise when a single anchor could fail when subjected to the forces of a load. Understanding how to construct multiple point anchor systems allows the rescuer to combine the strength of comparatively weaker anchors into one central anchoring point.

Two- and three-point multiple anchor systems can be constructed so they will "self-adjust." This means two things:

1. The system will allow for some change of direction in the force applied to the anchors.
2. The amount of force from the load is distributed to each of the anchor points.

It is subjective at best to attempt to rate the holding capacity of these systems. The rescuer must keep in mind that each of the single anchors was determined to be inadequate to support the estimated load. Failure of any of these single anchors in the multiple system will create a shock load to the remaining system. The result of this will most likely be failure of the entire system.

Two-point Self-adjusting Anchor System

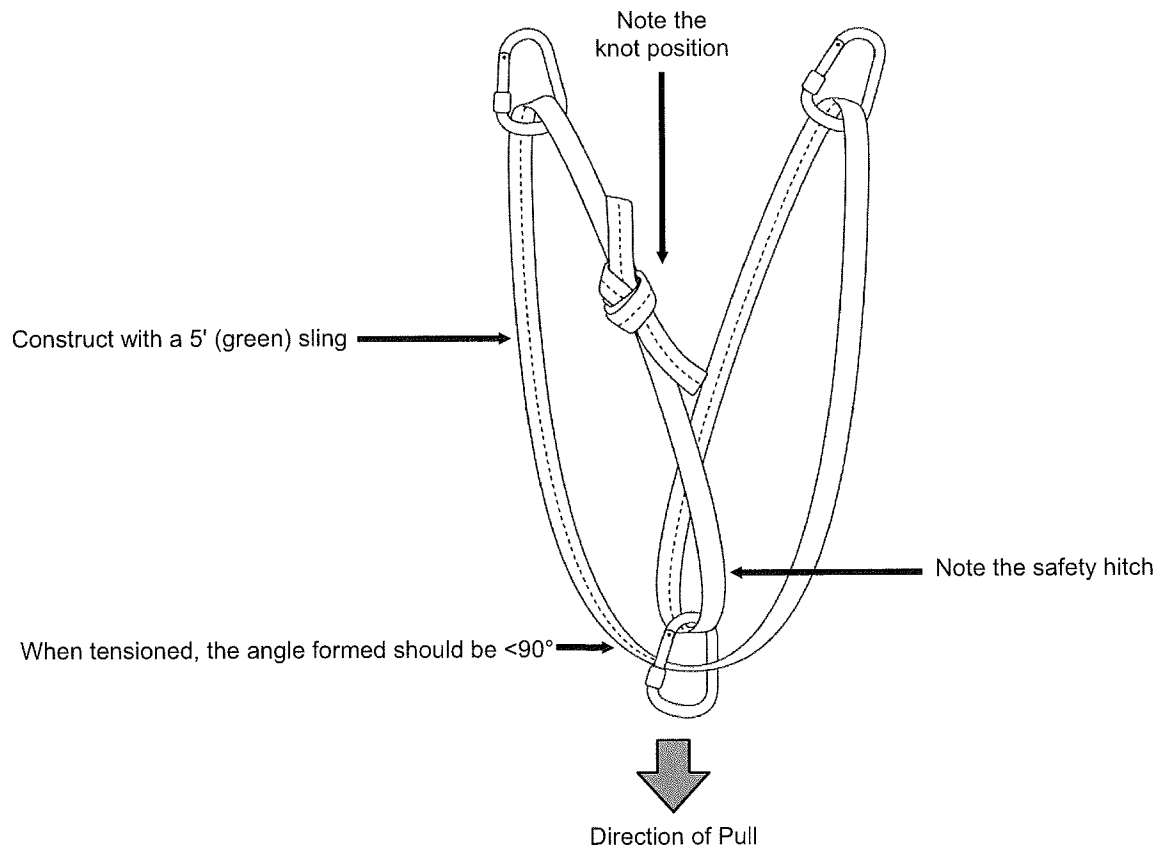

Figure 4-19: Two-point Self-adjusting Anchor System

Three-point Self-adjusting Anchor System

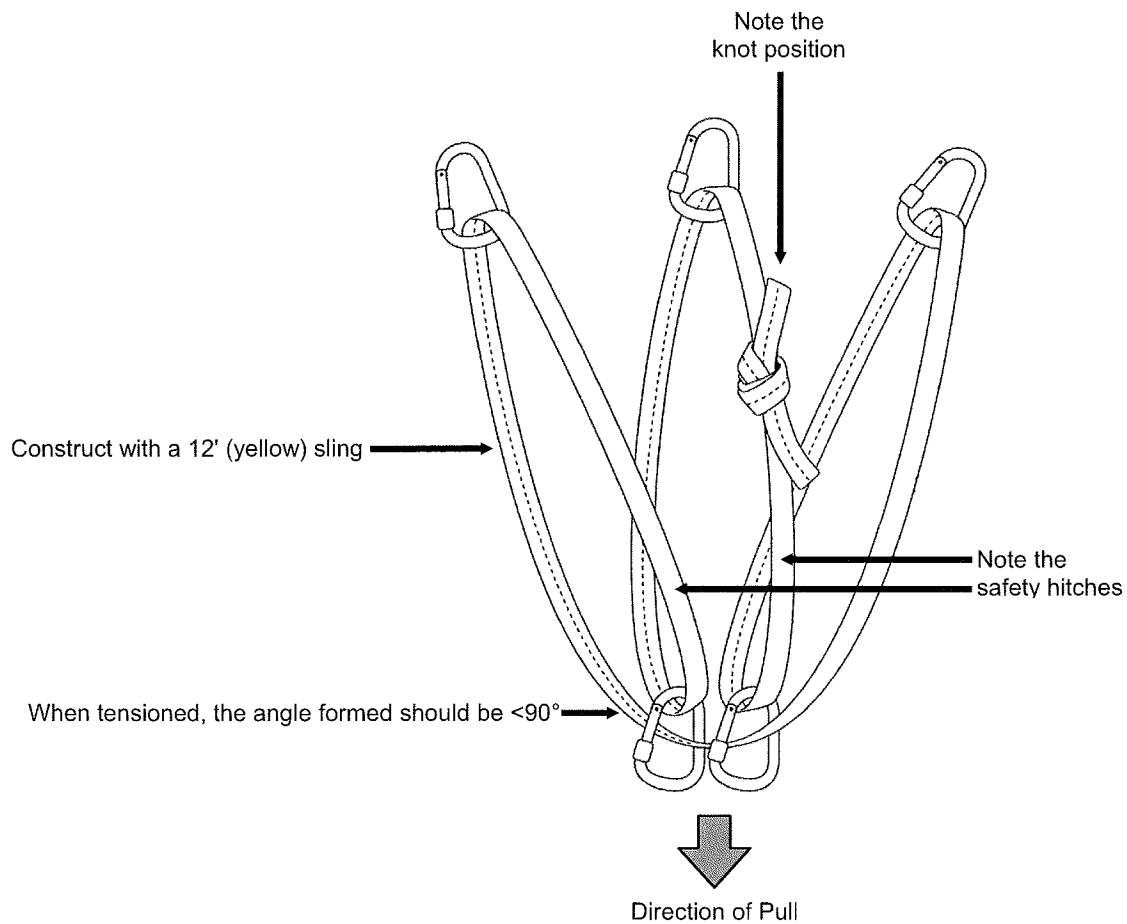

Figure 4-20: Three-point Self-adjusting Anchor System

Critical Angles

A major concern in constructing any self-adjusting multiple point anchor system is to ensure that the interior angle of the self-adjusting sling is directing less weight to each single anchor than that of the main load. The rescuer needs to know and understand the impact that this angle or its variations will have on the single anchors. Most agencies define the critical angle as between 45 and 90 degrees.

*How Angles Affect Load Distribution to Single Anchors**

45 Degree



Figure 4-21: 300# Load = 150# at each anchor
600# Load = 300# at each anchor

90 Degree

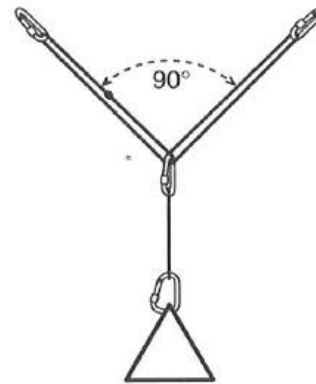

Figure 4-22: 300# Load = 210# at each anchor
600# Load = 420# at each anchor

120 Degree

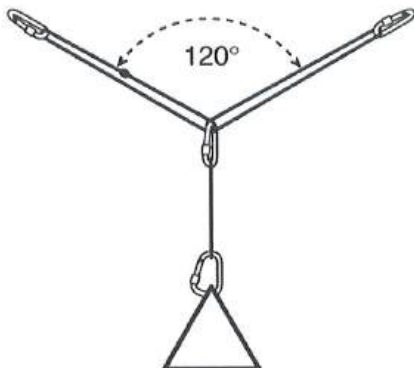

Figure 4-23: 300# Load = 300# at each anchor
600# Load = 600# at each anchor

160 Degree

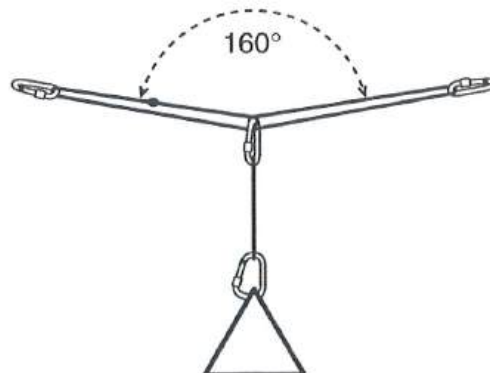

Figure 4-24: 300# Load = 1,125# at each anchor
600# Load = 2,250# at each anchor

* A single-person load is commonly estimated as 300 pounds and a two-person load as 600 pounds.

Tagged Anchor System

When the anchor points are not close together, tag lines made of webbing or lifeline, are used to extend them to a collection point where the self-adjusting sling is attached. This allows the legs on a self-adjusting sling to remain short. Tagged anchors also allow the attachment point of a single point anchor to be extended to a more desirable location.

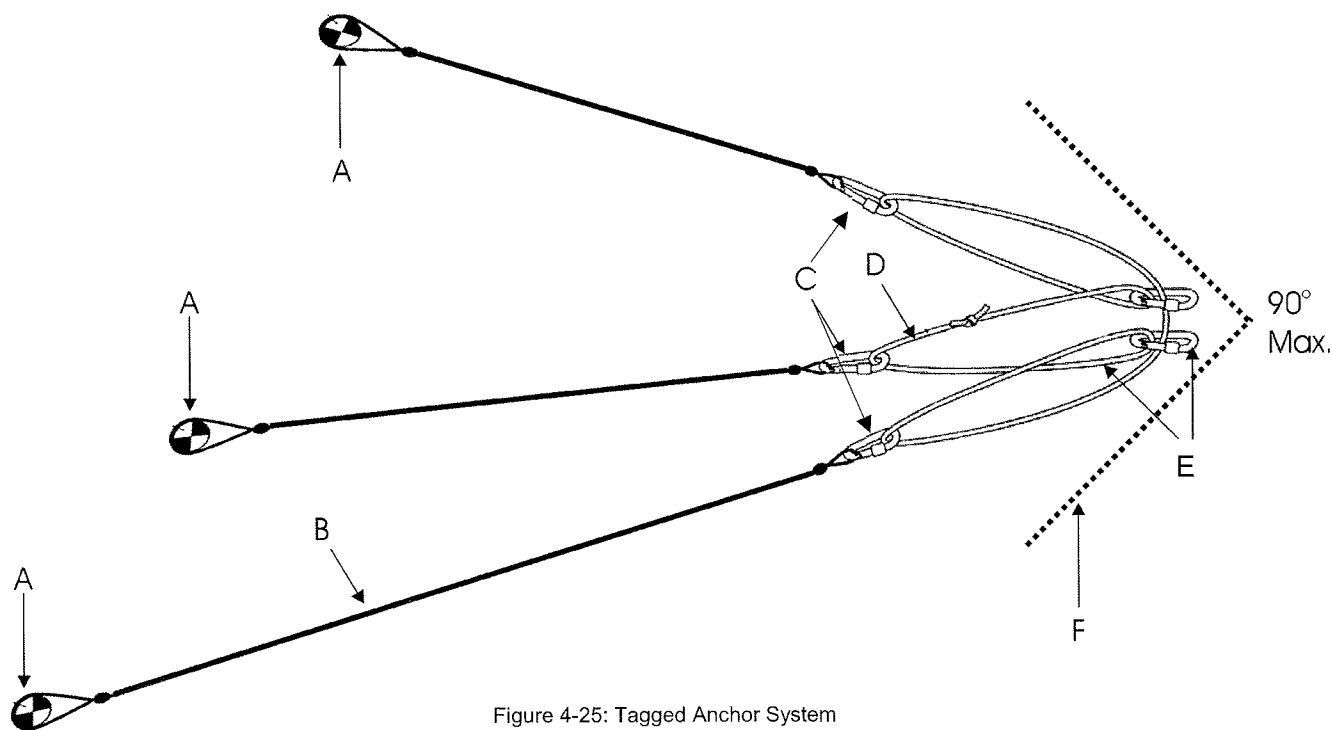

Figure 4-25: Tagged Anchor System

Components of a Self-adjusting Anchor

- A = The anchors of the system.
- B = Tag lines, if anchors are distant.
- C = Carabiners to join tag lines to the self-adjusting loop.
- D = Self-adjusting sling or loop.
- E = Safety loops and double carabiners.
- F = Proper field angle (45°-90°).

Windlassed Picket Systems

In most situations, anchors of some type can be found. A big fine tree, a big fine rock, apparatus components, or structural components usually can be identified and used. However, there are situations when none of the above is available, or they are not positioned sufficiently in line with the incident to be effective. Being able to utilize picket systems may be the solution to this problem.

The two types of windlass picket systems covered in this course are
1-1-1 Inline ✱ 1-1-1 Triangle

Ratings

- General use when in configurations of three and used in hard, compact soil.
 - Field testing shows over 5,000 pounds holding power.
- Light use (work positioning only, single person load) if single picket is used in hard, compact soil.
 - The Army Corps of Engineers rates a single picket at 700 pounds holding power.

Advantages

- Can be carried by rescue personnel to remote locations.
- Can predetermine the specific location to build the anchor system.

Disadvantages

- Strength and availability is dependent on soil type.
- Can be time consuming to set up.
- Can damage underground utilities.
- May be difficult to remove.

Common Specifications for Pickets

- 48" x 1" cold rolled steel.

Common Specifications for Tensioning Devices

- Usually a smaller size than a picket.
- 18"–24" long, ½"–¾" diameter.

System Set-up

- Each picket should be in a straight line with the direction of the load.
- Each picket should be driven at a 15° angle, tilted away from the load, to maximize its holding power.
- Driven 24"–36" into the soil.
- Spaced one picket length apart from each other.
- The pickets of these systems are connected to each other with lengths lifeline or webbing. This connecting technique is referred to a windlass.

The Steps to Form a Windlass

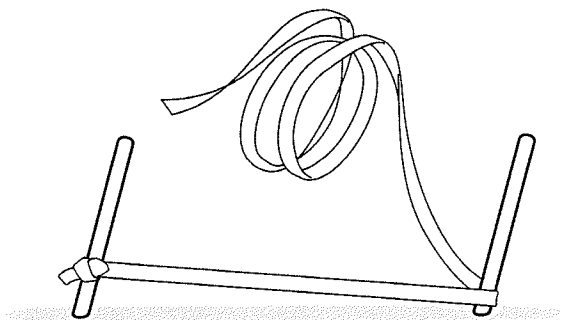

Figure 4-26: Step 1



Figure 4-27: Step 2

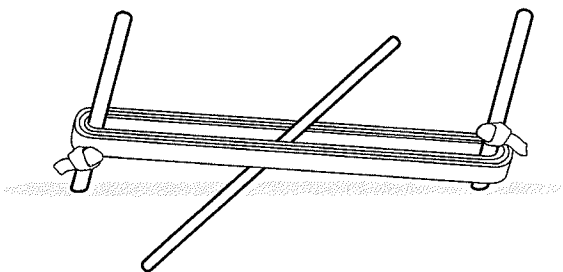

Figure 4-28: Step 3

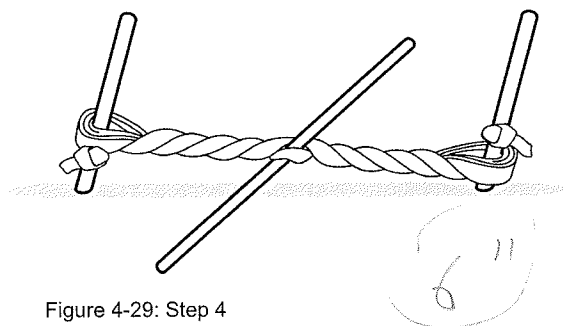

Figure 4-29: Step 4

1. Secure the end of the windlass material to the base of the front picket, approximately 2"–6" from ground level with a clove hitch or round turn and two half hitches.
2. Form a series of wraps around the base of one rear picket and the tie off point of the front picket and secure the end of the windlass material to either picket with a clove hitch or round turn and two half hitches.
 - Rope Minimum of two wraps (a 20-foot length should be adequate)
 - Webbing Minimum of four wraps (two 20-foot lengths of webbing tied together should be adequate)
 - Some teams will have 36- to 40-foot lengths of webbing prebagged for windlass material. It is common to see orange or a nonstandard color of webbing for this purpose.
3. Tighten the windlasses by inserting a tensioning device between the wraps and turning it, this will cause the loops to twist and tighten.
4. Continue to tighten until the front picket starts to move.
5. Secure the tensioning device by driving it into, or placing it on, the ground.

1-1-1 Inline Windlass Picket System

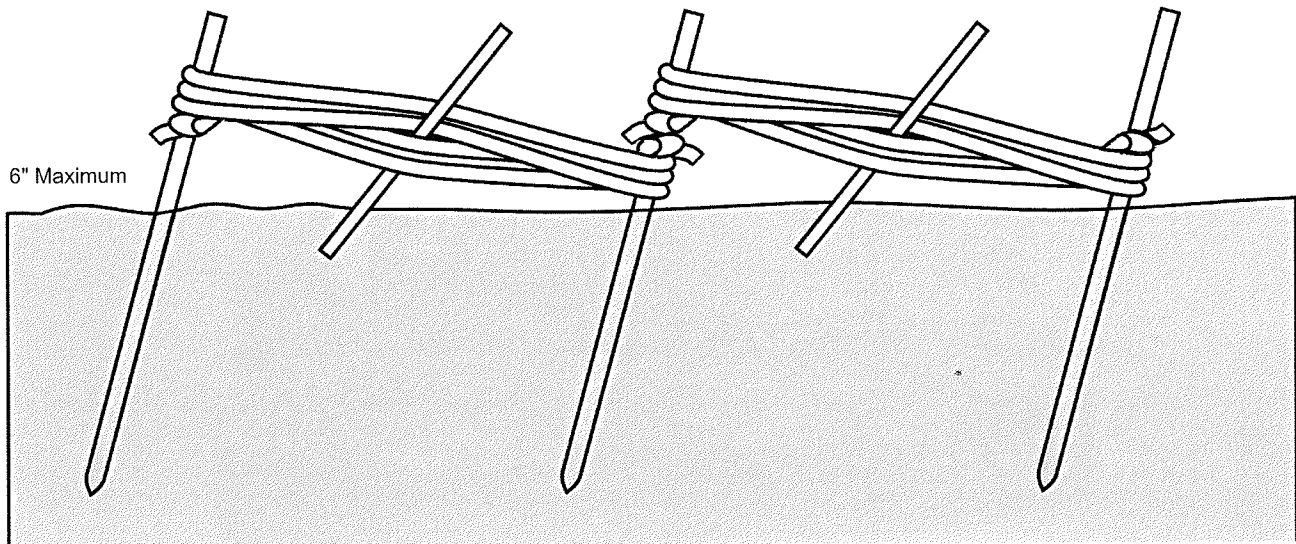

Figure 4-30: Side View

Shown with tensioning device inserted into the windlass material.

- Tension and secure rear windlass first.
- Note direction of load. This tends to be a directional type of anchor system.

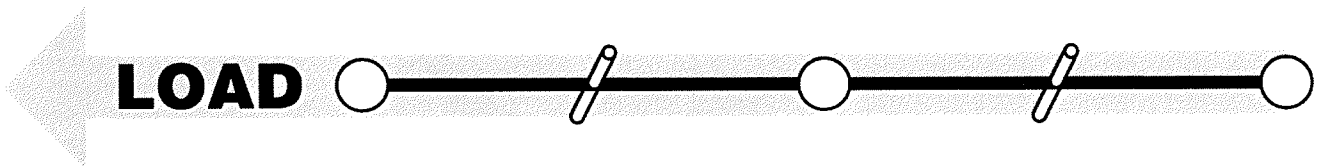

Figure 4-31: Top View

In situations where there will be only one direction of pull on the anchor, a 1-1-1 inline picket system can be used. This could be for a mainline that is set well back from the edge to accommodate an inline mechanical advantage system, a belay/safety line, or a secondary anchor for a mechanical advantage system.

This system is set up with three pickets placed inline. Each picket is spaced a picket length from the other. The load is shared by all three pickets through a windlass, each holding against the other.

A 1-1-1 inline picket system is strongest when the pull is along the line of pickets. If the load shifts, the load will be applied to only the front picket, and the anchor system may fail.

1-1-1 Triangle Windlass Picket System

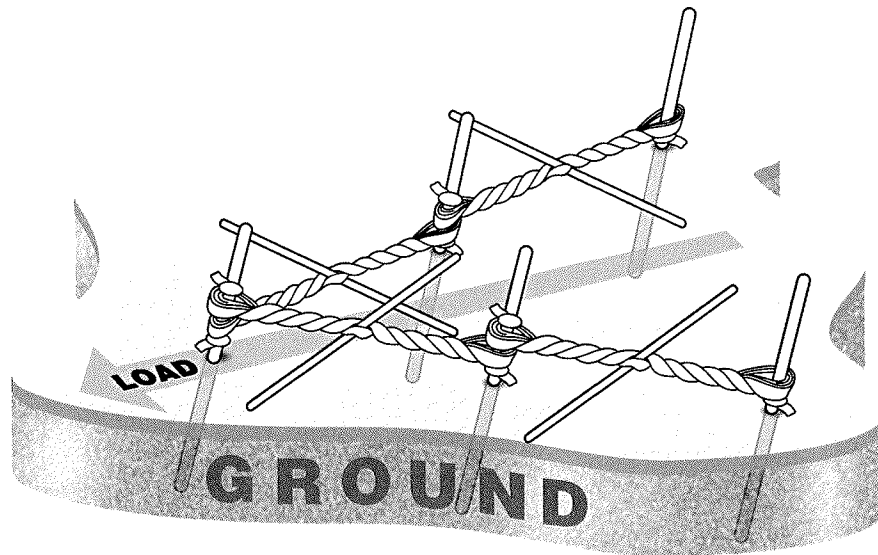

Figure 4-32: Side View

- ❑ Shown with windlass material tensioned and set.
- ❑ Note directions of load. This offers more flexibility in load changes than the 1:1:1 inline windlass picket system.

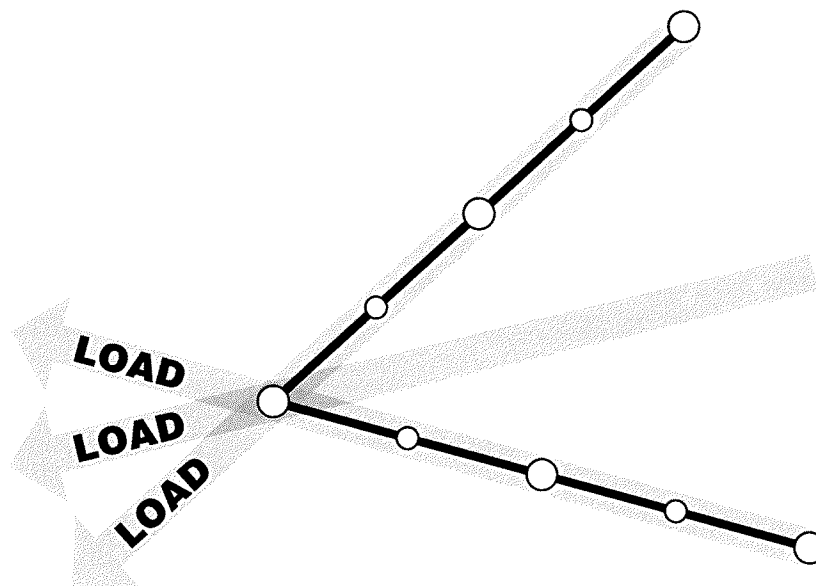

Figure 4-33: Top View

Chapter 5: Rescuer and Ambulatory Victim Packaging

Scope: This chapter serves as an introduction to rescuer and ambulatory victim packaging.

Terminal Learning Objective (TLO): At the end of this chapter, the student will be aware of how to properly package rescuers and victims to safely and effectively complete a rope rescue operation.

Enabling Learning Objectives (ELO):

1. Describe rescue harnesses and rescuer packaging
2. Demonstrate how to don a class ii harness
3. Demonstrate how to package a victim in a commercial victim harness
4. Demonstrate how to package a victim in a hasty pelvic harness

Proper packaging of rescuers and victims is essential to a safe and effective rope rescue operation. It is imperative that all rescuers have the knowledge, skill, and ability to efficiently and effectively place a harness on themselves as well as an ambulatory victim.

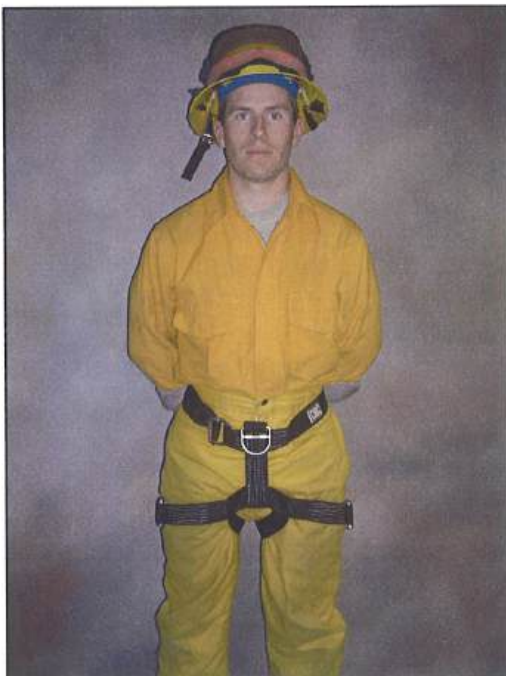

Figure 5-1: Class II Harness

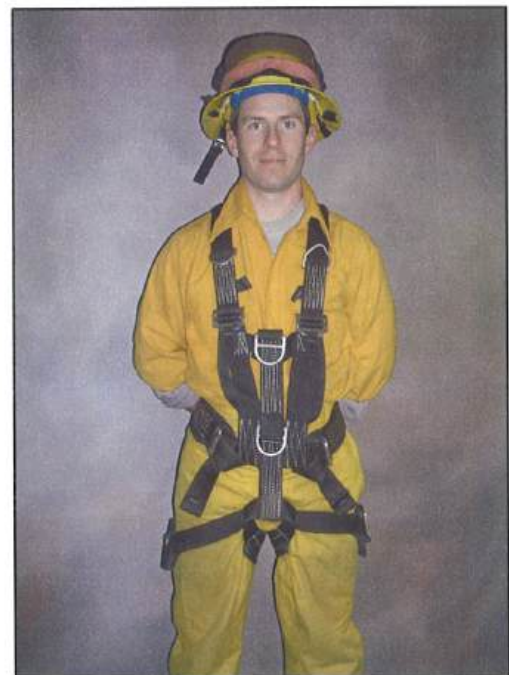

Figure 5-2: Class III Harness

Rescuer Packaging

There are several commercially manufactured rescue harnesses available. The minimum standard for this course is NFPA 1983 Class II harnesses. A Class III harness may be used if equipped with a front waist D-ring for low angle attachments to the rope system. Harnesses are required for all rescuers going over the edge as well as those positioned within ten feet of the edge.

- Package rescuers per manufacturer's specifications.
 - Proper fit of harnesses on students/rescuers must be ensured by qualified instructor.

Sample NFPA Class II Harness Instruction Card

USER INSTRUCTIONS

NFPA Standard 1983 recommends separating the user instructions from the harness and retaining them in permanent record. The standard also recommends making a copy of the instructions to keep with the harness and that the instructions should be referred to before and after each use. Additional information regarding life safety harnesses can be found at least in the NFPA 1500, Standard on Fire Department Occupational Safety and Health Program and NFPA 1983, Standard on Fire Service Life Safety Rope and System Components.

INSPECTING YOUR HARNESS

Inspect the harness according to your department's policy for inspecting life safety equipment. The harness should be inspected after each use by an inspector that meets your department's training standard for inspection of life safety equipment. Record the date of the inspection and the results in the equipment log or on a tag that attaches to the harness. Each user should be trained in equipment inspection and should do a cursory inspection before each use.

When inspecting the harness, check the webbing for cuts, worn or frayed areas, broken fibers, soft or hard spots, discoloration, or melted fibers. Check the stitching for pulled threads, abrasion, or breaks. Check the hardware for damage, sharp edges, and improper operation. If any of the above is noted, or if the harness has been subjected to shock loads, fall loads, or abuse other than normal use, remove the harness from service and destroy it. If there is any doubt about the serviceability of the harness, remove the harness from service and destroy it.

PUTTING ON YOUR HARNESS

Loosen the waist strap and leg loops as far as possible, but do not pull the web out of the buckles. Hold the harness in front of you. Make sure the D-ring loop is in front and the leg loops are not twisted. Lower the harness until the leg loops are laying on the ground in the proper position. Step over the waist belt and into the leg loops.

Pull the harness up around your hips and tighten the waist strap until it is snug and the D-Ring is centered. Next, adjust the leg loops to the desired tightness. In most cases, snug waist and leg loops provide the best comfort. Time spent practicing donning the harness and adjusting the straps will increase your level of comfort and your ability to quickly put on and adjust the harness.

WARNING: Make sure that the harness fits snugly and that all the buckles are secure before using the harness. Make sure the ends of all straps are secured or are tied off using an overhand knot as shown on the right. When wearing the harness, double-check the buckles, adjusters, and fit of the harness immediately prior to relying on it for support. High impact fall situations should be avoided. Always keep the safety line (belay) above the wearer. Always minimize the slack in the safety line. To prevent roll out, always use locking carabiners when connecting to the D-Rings.

USING YOUR HARNESS

For ascending, descending, and static belays, use a carabiner to connect directly to the front, waist D-Ring. There is plenty of room for extra carabiners. The CMC Rescue Harness is not intended for rock climbing. Lead climbing ropes should not be tied into the D-Ring or connected into it with a carabiner.

CARRYING, MAINTENANCE, AND STORAGE

During use, carrying, and storage, keep the Utility Harness away from acids, alkalis, exhaust emissions, rust and strong chemicals. Do not expose the harness to flame or high temperatures. Carry the harness where it will be protected as it could melt or burn and fail if exposed to flame or high temperatures. If the Utility Harness becomes soiled, it can be washed in cold water with a mild detergent. Dry out of direct sunlight. Do not dry in an automatic dryer. Store in a cool, dry location. Keep the harness away from acids, alkalis, exhaust emissions, rust or strong chemicals during storage or use. Do not store where the equipment may be exposed to moist air, particularly where dissimilar metals are stored together.

Ambulatory Victim Packaging Overview

Rope rescues will often involve victims that do not need to be carried out of a steep environment in a rescue litter. Often, they have simply become stuck on a steep cliff or hillside. Other times they may have been minorly injured during a fall of some type. In these situations, the rescuer must be able to quickly and effectively secure the victim with a harness and into the rope rescue system. Once the victim is secured to the system, they can walk along with the ropes as they are raised or lowered to a safe environment. Rescuers have historically performed this task with a Hasty Harness tied out of webbing. In recent years, commercial victim pelvic harnesses have become available and are now the preferred method for packaging ambulatory victims if available.

Ambulatory Victim Packaging

Method 1: Commercial Victim Pelvic Harness

There are a variety of commercially manufactured victim pelvic harnesses on the market. All models attach quickly and securely around the waist and thighs or under buttocks no matter where or how the victim is positioned. The design allows the harness to be put on without the victim having to step into the harness. Package victim per manufacturer's specifications.

Sample Victim Harness Instructions

The ProSeries Lifesaver™ Victim Harness is intended for use on a victim and not as a harness for the rescuer. With proper training and adequate practice, a rescuer should be able to quickly secure a victim with the waist strap then add the leg loops for safer support. The straps are color coded to simplify connecting the correct buckle and V-Ring in order to prevent uncomfortable twists in the harness. While the Lifesaver™ can be used in any situation where the victim needs a harness, it is particularly valuable when the victim is in a precarious position and the rescuer is working on rappel.

Before using the Lifesaver™ Harness in a high angle rescue, or training, practice putting the harness on while on the ground. As in any rescue situation, proper safety precautions and appropriate belays should be used for rescuer and victim.

USER INSTRUCTIONS

NFPA Standard 1983 recommends separating the user instructions from the harness and retaining the instructions in a permanent record. The standard also recommends making a copy of the instructions to keep with the harness and that the instructions should be referred to before and after each use.

Additional information regarding life safety harnesses can be found at least in the NFPA 1500, *Standard on Fire Department Occupational Safety and Health Program* and NFPA 1983, *Standard on Fire Service Life Safety Rope and System Components*.

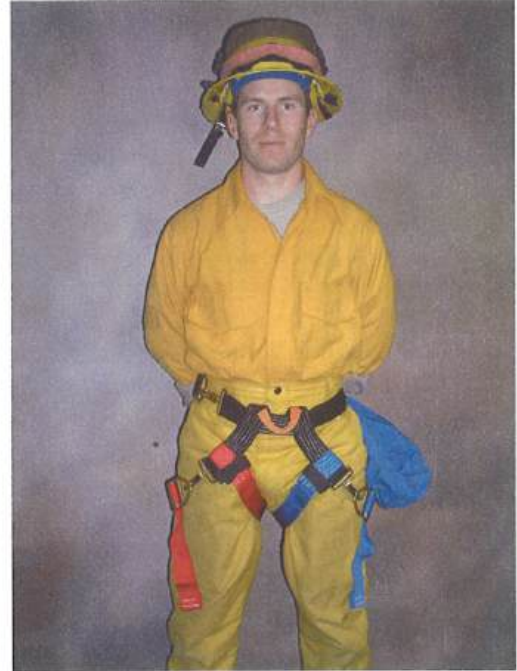

Figure 5-3: Commercial Victim Harness

INSPECTING YOUR HARNESS

Inspect the harness according to your department's policy for inspecting life-support equipment. The harness should be inspected after each use and at least once a year by an inspector that meets your department's training standard for inspection of life-support equipment. Record the date of the inspection and the results in the equipment log or on a tag that attaches to the harness. Each user should be trained in equipment inspection and should do a cursory inspection, and check component compatibility before each use.

When inspecting the harness, check the webbing for cuts, worn or frayed areas, broken fibers, soft or hard spots, discoloration, or melted fibers. Check the stitching for pulled threads, abrasion, or breaks. Check the hardware for damage, sharp edges, and improper operation. If any of the above is noted, or if the harness has been subjected to shock loads, fall loads, or abuse other than normal use, remove the harness from service and destroy it. If there is any doubt about the serviceability of the harness, remove the harness from service and destroy it. When operating under EN standards the user should retire the harness 5 years after date in service, regardless of its condition.

PREPARATION

After inspection, the Lifesaver™ Harness should be packed in its distinctive blue storage bag so that it is ready for the next deployment. Start by pulling the leg V-Rings all the way to the end of the straps. Then fold the leg straps back and forth and secure them with the hook and loop strap. Be sure to position the V-Ring so that it can be pulled down and towards the center. Pull the waist strap V-Ring all the way to the end. Do not connect the waist buckles. Stuff the harness into the bag so that the waist loop (orange) is at the top.

PUTTING ON THE HARNESS

We use the following method for putting on the harness for the most common situations. Practice with this method should allow you to modify the steps to meet unusual situations.

1. Start by pulling the waist loop (orange) out of the bag. Attach a carabiner to it and clip it onto the victim's anchorage point. This could be:
 - To your descender with a Pick-off or Multi-loop Strap.
 - To a separate rope intended for the victim.
 - To your rope with a prusik hitch or ascender.

In any situation, the anchorage point should be above the victim. Tighten the drawstring so the harness does not fall out on the way down and make sure the bag will not interfere with your rappel.

2. Rappel to a position level with and to the left of the victim. Lock off your descender and secure your belay.
3. Pull the drawstring to open the bag and remove the harness completely out of the bag. Hold the waist buckle (black) in your left hand. The waist loop (orange) should be next to your wrist. The "ProSeries" label should be towards the victim.
4. Reach around and clip the waist V-Ring into its buckle. Center the waist loop (orange) to the victim's front and tighten the waist belt snugly. Take up any slack in the victim's belay.
5. Pull the leg loops down, between the legs, and to the outside of the victim's body.
6. Clip the V-Rings into the buckles of the matching color. Pull the ends to tighten so the leg loops fit snugly. If you are concerned about the buckles slipping, tie an overhand knot in the end of all the straps.
7. Check the following:
 - The V-Rings are securely clipped into each buckle.
 - The harness is snug and not pinching or binding.
 - The buckles are not causing the victim any discomfort.
 - The victim's carabiners are locked.

Method 2: The Hasty Pelvic Harness



Figure 5-4



Figure 5-5

1. Tie a 15-foot piece of webbing into a loop forming a sling using an overhand bend.
2. Place the overhand bend knot in the small of the rescuer's back at waist height with the rescuer's hands on either side of the bend.



Figure 5-6



Figure 5-7

3. Wrap the webbing around the waist creating bights at each hip and allowing the lower part of sling to hang behind the knees.
4. Slide both hands under the bights near the hips and move hands through the bights and over the front of the thighs.
5. Grasp the lower part of the sling near the knees with both hands.



Figure 5-8

6. Slide both hands back up over the thighs and through the bights at the hips while maintaining grip on lower part of loop with both hands.
7. This will create two bights of webbing. Hold them in one hand while you use the other to work any loose or slack webbing out around the waist and thighs.

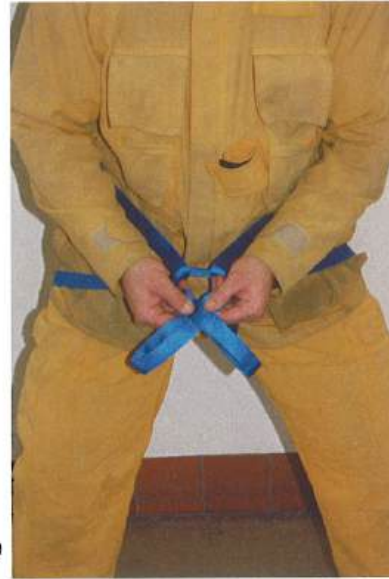

Figure 5-9

8. Tie the two bights together by crossing the bight on the right over the left and pulling it up through the hole created.



Figure 5-10

9. Pull this knot snug.



Figure 5-11

10. Finish the knot by crossing the bight on the left over the bight on the right, pulling it up through the hole created, and forming a square knot.



Figure 5-12

11. Pull this knot snug.



Figure 5-13

12. Attach a carabiner through both bights.



Figure 5-14

13. Finished hasty pelvic harness.

The student must be able to attach this harness around himself or herself as well as a victim.

Chapter 6: Types of Litters and Victim Packaging

Scope: This chapter serves as an introduction to rescue litters and victim packaging.

Terminal Learning Objective (TLO): At the end of this chapter, the student will be aware the role of the rescue litter and how to secure a victim in order to move over unstable terrain.

Enabling Learning Objectives (ELO):

1. Describe the types of rescue litters
2. Describe the specifics, advantages, and disadvantages of metal, metal/plastic, and plastic rescue litters
3. Demonstrate how to secure a victim to a rescue litter
4. Describe the considerations for packaging nonambulatory victims in unstable terrain

Rescue litters serve several purposes during rope rescue operations. They provide stabilization and protection for the victim to protect them against hazards such as protruding rocks while being evacuated. The litter also serves to provide a way for the rescuers to easily handle the victim over terrain. The rescue litter also provides a foundation to which ropes can be attached to assist in raising or lowering a victim on sloped terrain. Due to its size, a rescue litter is not easily used in confined space or limited access areas.

Rescue Litters

The rescue litter, or Stokes basket as it is commonly referred to, has been the standard for victim removal over rough terrain for many years. It can be carried by hand over mild terrain, or used in tandem with ropes or ladders to negotiate steep or rough terrain. The rescue litter by itself does not provide spinal immobilization. A victim requiring C-spine immobilization should first be placed on a backboard, which is then placed inside the litter.

Rescue litters should be inspected regularly for bends, cracks, broken welds, and damage or wear to any plastic. Cleaning can be performed with mild soap and water. Decontamination can be accomplished as per department policies.

Litters come in a variety of shapes and materials. This course will discuss the three most common types of litters.

- ① Metal litters
- ② Metal/plastic litters
- ③ Plastic litters

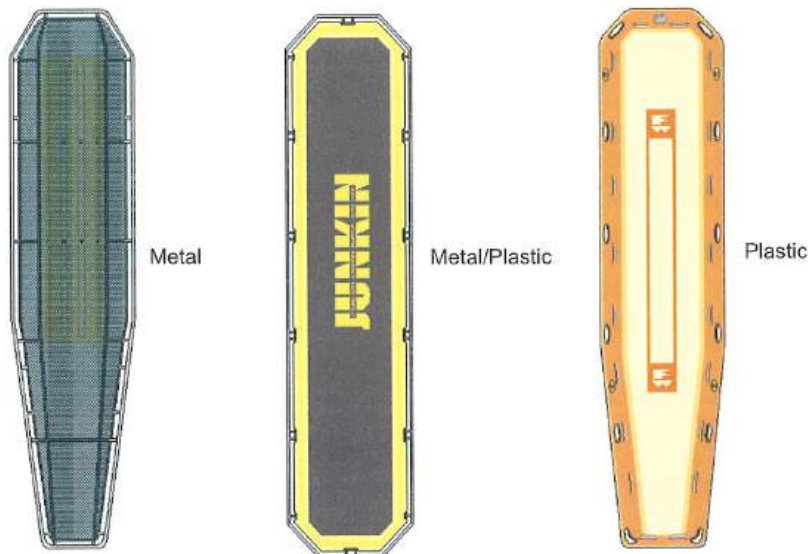

Figure 6-1: Common Litters

Metal Litters

Specifics

- The most commonly used rescue litter.
- Metal frame with wire, mesh, or nylon victim bearing surface.
- Various metals used for construction from heavy-duty steel to lightweight titanium.
- Multiple designs from rectangular to tapered leg models.

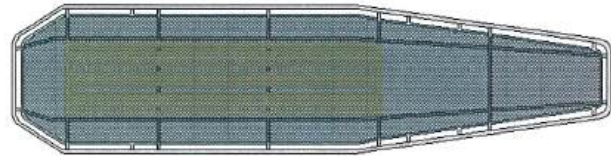

Figure 6-2: Metal Litter

Advantages

- Excellent strength and durability.
- Multiple lashing options and points of attachment.

Disadvantages

- Heavy and often bulky for confined spaces or restricted areas.
- May present a snagging or entanglement hazard.

Metal/Plastic Litters

Specifics

- Metal frame with a plastic shell attached to frame as victim bearing surface.
- Usually rectangular.



Figure 6-3: Metal/Plastic Litter

Advantages

- Metal frame is strong and durable enough for rope rescue operations.
- Slides easily over obstacles.

Disadvantages

- Limited lashing options and limited points of attachment.
- Plastic is vulnerable to wear and damage.
- Plastic will degrade if stored in sunlight for long periods of time.

Plastic Litters

Specifics

- Litter is a plastic shell with a metal rail that forms a ring around the rim of the litter.
- Usually rectangular in shape but may be tapered at the foot.

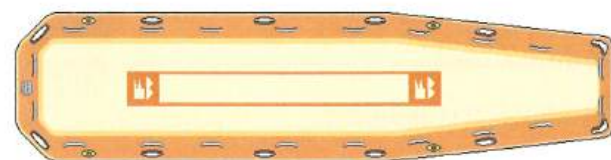

Figure 6-4: Plastic Litter

Advantages

- Lightweight.
- Useful for snow and water evacuations.

Disadvantages

- These litters are generally not the best choice for rope rescue operations due to their lack of structural stability.
- Limited lashing options and points of attachment.
- Plastic is vulnerable to wear and damage.
- Plastic will degrade if stored in sunlight for long periods of time.

How to Secure a Victim to a Rescue Litter

Victim packaging is an essential skill for all rescuers. If a victim is insufficiently secured to the litter, existing injuries can be worsened, and new injuries can be created. Victims are generally secured to the litter with interior and exterior lashings. Interior lashing consists of chest and pelvic lashings, which keep the victim from sliding out the head or foot of the litter. External lashing consists of webbing or other straps that are arranged across the victim from one side of the litter to the other; this keeps the victim from coming out the top of the litter. All victim lashings should be secured to structural members of the litter other than the top rail to avoid abrasion. Interior and exterior lashings are commonly constructed using twenty-foot sections of webbing though longer sections may be needed with large victims.

Interior Lashing

To improve efficiency, webbing should be placed into the rescue litter before the victim, and oriented as shown.

1. Lay a 20-foot piece of webbing across the litter with the middle at the point where the victim's crotch will be.
2. Form an 18" loop in the middle of a second 20-foot piece of webbing and lay it in the litter so that the top of the loop is where the top of the victim's head will be.

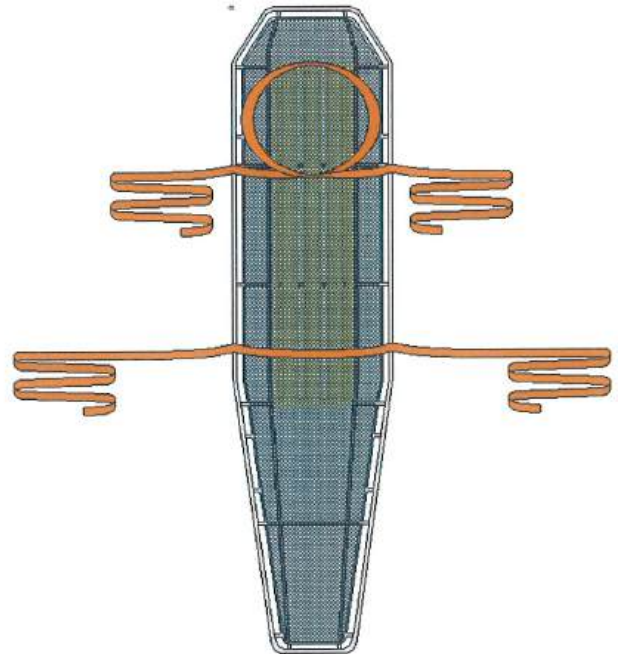

Figure 6-5: Steps 1 and 2 Prepping the Litter

Chest Lash

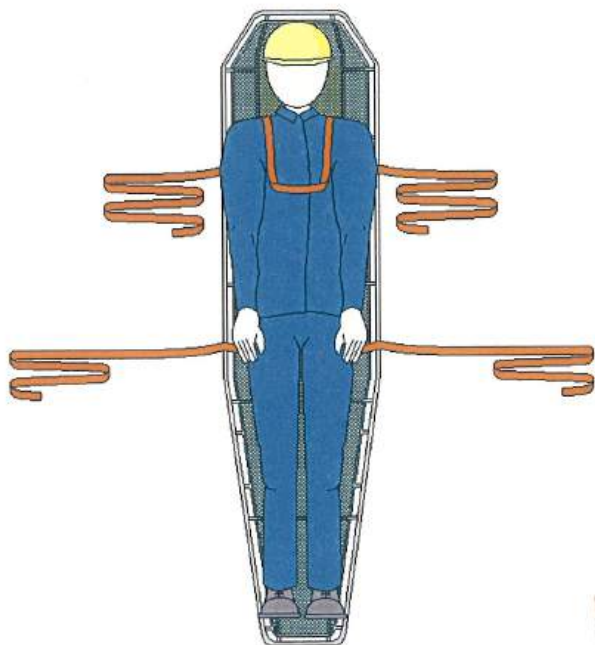

Figure 6-6: Step 1

1. Pass the loop over the victim's head to the victim's nipple line.

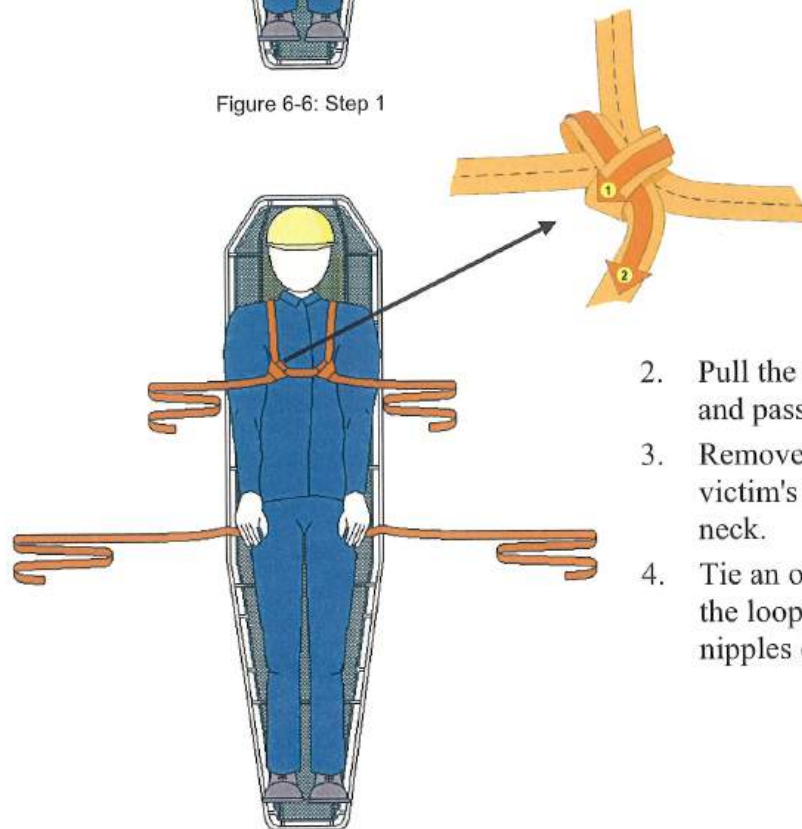

Figure 6-7: Steps 2-4

2. Pull the webbing ends from under each arm and pass through loop at chest.
3. Remove slack ensuring crossed webbing at victim's shoulder blades does not ride up on neck.
4. Tie an overhand knot in the webbing around the loop at the point it passes over the nipples on each side.

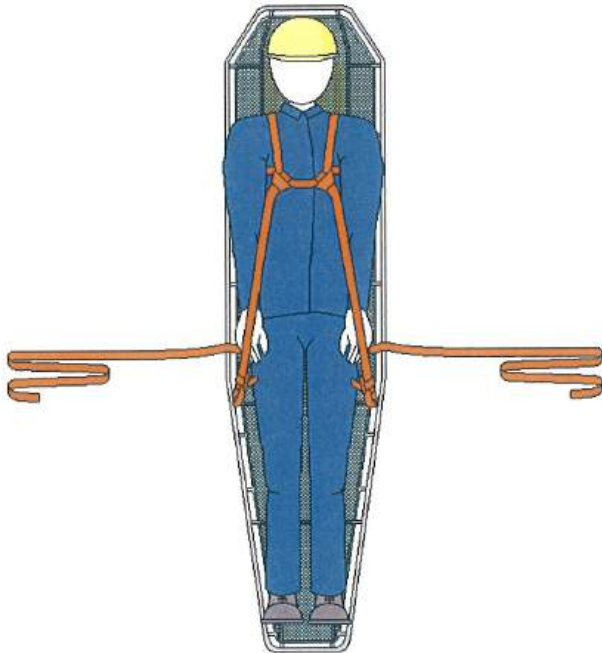

Figure 6-8: Steps 5 and 6

5. Tie a round turn and two half hitches at the ends of the webbing around a rib below the victim's waist where the rib meets the main frame.
6. Keep even tension between the two ends of the webbing when tying the knots.

Pelvic Lash

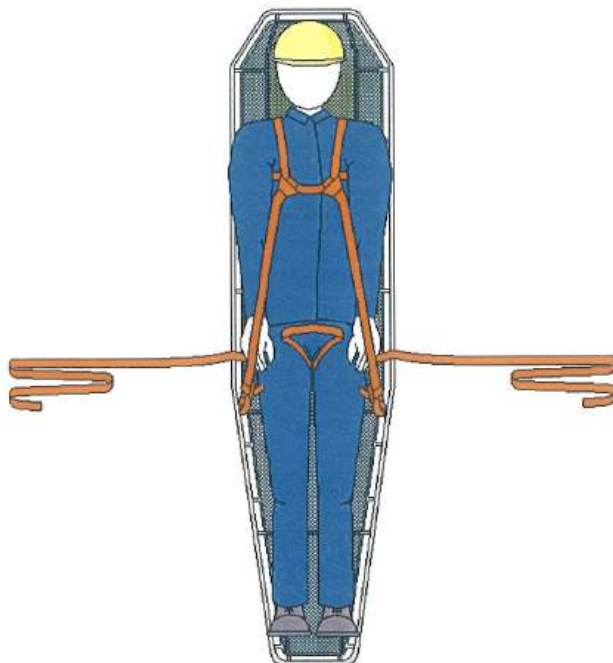

Figure 6-9: Step 1

1. Pull midpoint of webbing between legs up to victim's waist creating a 6" triangle.

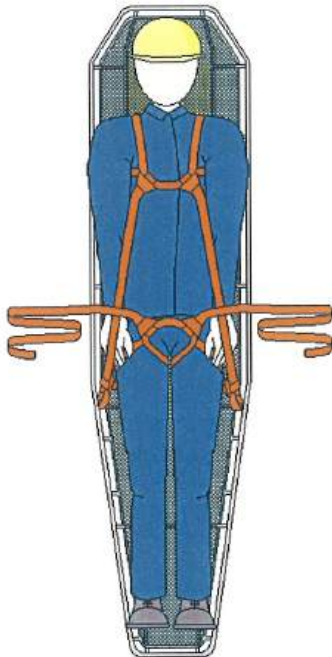

Figure 6-10: Steps 2 and 3

2. Pass ends of webbing around thighs and through triangle pulling up towards shoulders to remove slack.
3. Tie an overhand knot in the webbing on each side at the point it passes through the triangle.

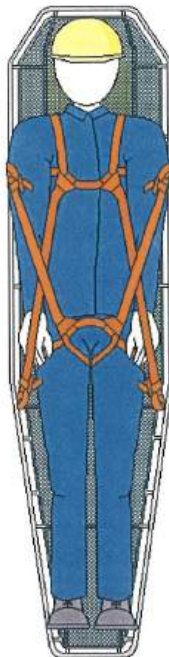

Figure 6-11: Steps 4 and 5

4. Tie a round turn and two half hitches at the ends of the webbing around a rib near the victim's shoulders where the rib meets the main frame.
5. Keep even tension between the two ends of webbing when tying the knots.

Exterior Lashing



Figure 6-12: Steps 1-7

1. Place a 20-foot piece of webbing across the victim's legs with the mid point at or below the knees.
Note: Depending on the victim's size, the 20-foot piece of webbing may be too short. Either tie another piece of 5- or 12-foot webbing to the 20-foot length or cut a 25- or 30-foot piece of webbing specifically for exterior lashing.
2. Pass the ends of the webbing around the rib at or below the victim's knees on both sides where the rib meets the main frame.
- DO NOT WRAP THE MAIN FRAME!**
3. Cross the webbing and pass the ends of the webbing around the next rib moving towards the head.
4. Repeat this operation until webbing passes around the ribs near the victim's shoulders.
5. Tie a round turn and two half hitches at one end of the webbing around the rib to secure the end.
6. Remove slack by pulling webbing from secured end toward free end.
7. Tie a round turn and two half hitches with the free end around the rib to secure the webbing.

Alternative Victim Packaging (Optional)

There are several alternative methods available for lashing a victim to the litter. Many agencies are now using commercially available victim packaging equipment in place of the traditional webbing lashings. These methods of victim packaging are designed to make the job of packaging a victim more efficient. Each method has advantages and limitations and requires specific training for safe and efficient use. This text will present one method of alternative packaging. This method is **not** a FSTEP standard for victim packaging; it is an example of a regional standard developed through a local fire and EMS effort. The instructor may choose to incorporate local standards into his or her course content.

Equipment Needed

- One rescue litter.
- One NFPA Class II harness or victim harness.
- One backboard.
- Two sets of adjustable Velcro "spider" straps.

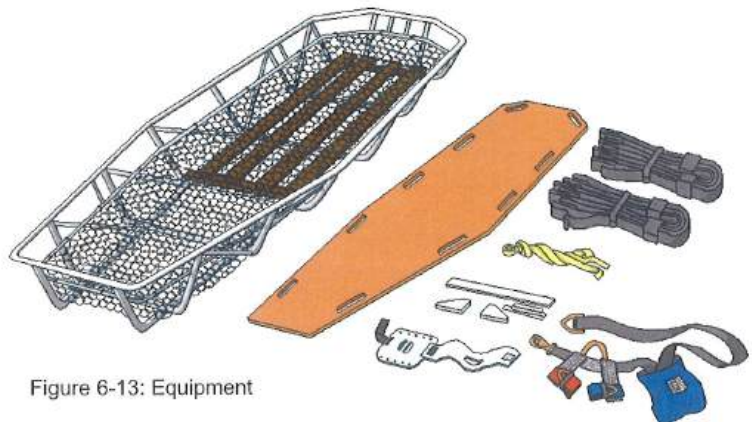

Figure 6-13: Equipment

- One C-spine and head immobilizer.
- One 12-foot section of webbing.

Advantages

- Quick and reliable means of securing a victim to litter.

Disadvantages

- Harnesses can be difficult to place around some victims.
- The number of victims may exceed the number of victim harnesses. In this case, the webbing hasty harness described in Chapter 5 should be considered.
- Adjustable Velcro "spider" straps are not well suited to use with children or very large adults due to minimal Velcro overlap. In this case consider:
 - Size specific adjustable Velcro "spider" straps, i.e., small or x-large.
 - Webbing exterior lashing.

Uses

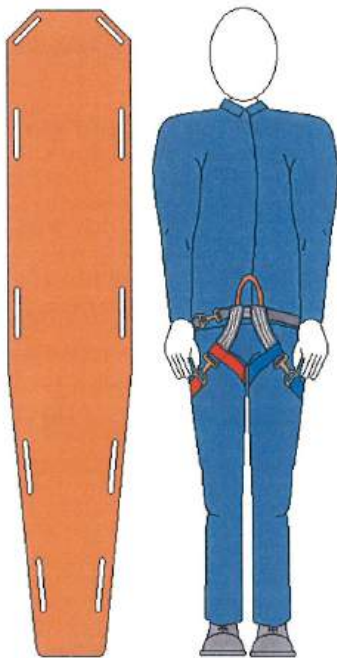

Figure 6-14: Step 1

1. Place a victim harness on the victim before placing in the backboard or litter.

2. If the victim requires C-spine immobilization, place on a backboard and secure per local protocols.



Figure 6-15: Step 2

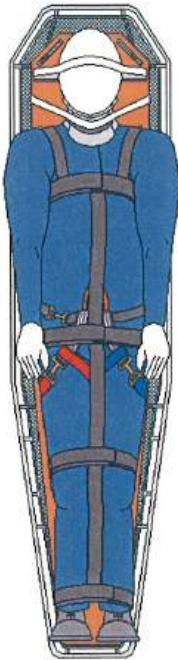

Figure 6-16: Step 3

3. Place the victim into the rescue litter.

4. Secure midpoint of 12-foot webbing to the victim harness attachment point with a lark's foot.
5. Secure the ends of the 12-foot webbing to the litter at or above the victim's shoulders with a round turn and two half hitches.

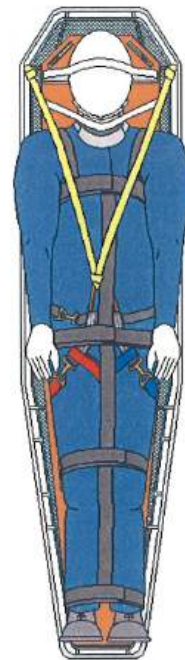

Figure 6-17: Steps 4 and 5

6. Place the adjustable straps along the body.
7. Secure the cross straps to the lower rail of the litter across chest, pelvis, femurs, and shins.
8. Place the shoulder straps over the shoulders and secure to the lower rail of litter.

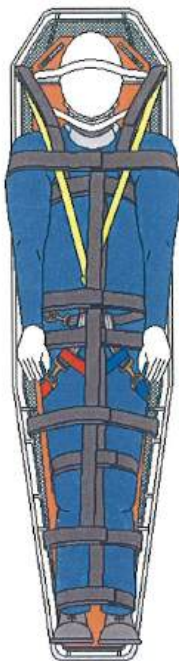

Figure 6-18: Steps 6-8

Considerations for Packaging Nonambulatory Victims in Unstable Terrain

- If the victim is in danger of falling, secure the victim to the main and belay/safety line with the victim harness and prusiks.
- Position the rescue litter below the victim in a horizontal, level position as if it is flat on the ground.
 - Secure the rescue litter in place against the rescuer's knees.
- Ease the victim onto the rescue litter and package as shown previously in this chapter.
- Once packaged, the rescue litter can be placed in a normal position for the raise.

Chapter 7: System Attachments and Fall Restraint

Scope: This chapter serves as an introduction to system attachments and fall restraint.

Terminal Learning Objective (TLO): At the end of this chapter, the student will be aware of several methods of system attachments for rescuers and victims.

Enabling Learning Objectives (ELO):

1. Describe system attachments and fall protection
2. Demonstrate how to attach a rescuer to a rope rescue system
3. Demonstrate how to attach an ambulatory victim to a rope rescue system
4. Demonstrate how to attach a rescue litter to a rope rescue system
5. Demonstrate how to attach a litter to a rope rescue system with three rescuers
6. Demonstrate how to attach a litter to a rope rescue system with four rescuers
7. Demonstrate how to attach a rescuer to a fall restraint system

This chapter describes several methods of system attachments for rescuers and victims. The systems addressed are:

- Rescuer attachment to a rope rescue system.
- Ambulatory victim attachment to a rope rescue system.
- Litter attachment to a rope rescue system.
- Litter harness (pre-rig) attachments to a rescue system.
 - Three-rescuer configuration.
 - Four-rescuer configuration.
- Rescuer attachment(s) to the litter harnesses.
 - Three-rescuer configuration.
 - Four-rescuer configuration.
- Rescuer attachment to fall restraint systems.

Rescuer Attachment to a Rope Rescue System

In low angle operations, the main and belay/safety lines are attached to the rescuers pelvic harness.

Specifics

- NFPA Class II harness minimum.
- Main line attached to front waist D-ring with NFPA General rated carabiner.
- Belay/safety line attached to front waist D-ring with NFPA General rated carabiner.

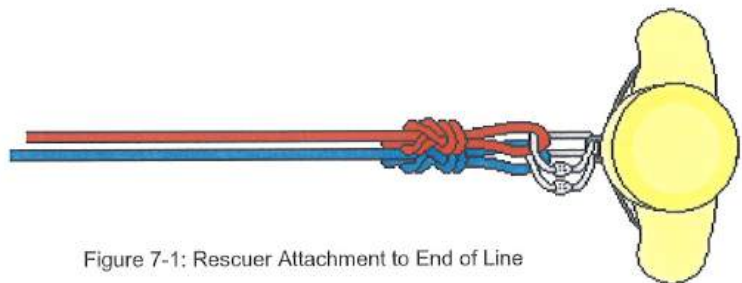

Figure 7-1: Rescuer Attachment to End of Line

Advantages

- Attachment at front waist D-ring allows excellent mobility for rescuer.
- Allows rescuer's posture to remain perpendicular to the slope.

Disadvantages

- Attachment at front waist D-ring can allow rescuer to completely invert in the event of a fall, or foot entrapment during lowering operations.

Ambulatory Victim Attachment to a Rope Rescue System

It is common to encounter an ambulatory victim during rope rescue operations. The victim is packaged in either a commercial victim harness or a hasty pelvic harness. Once the victim is packaged, he or she must be attached with prusiks into the main and the belay/safety lines that are already connected to the rescuer. The longer prusiks are commonly utilized for this attachment. This victim will then be able to walk up or down the slope with controlled assistance from the rope rescue system.

Specifics

- The preferred victim harness is commercially produced. If such a harness is not available, the hasty harness shown in Chapter 5 can be utilized.
- The victim is secured to the main line with a three-wrap prusik around the main line, connected to the front waist attachment on the harness with a NFPA General Use carabiner.
- The victim is secured to the belay/safety line with a three-wrap prusik around the belay/safety line and connected to the front waist attachment on the harness with a NFPA General Use carabiner.
- Position the victim ahead of the rescuer so that the rescuer can assist the travel of the victim.

Advantages

- Prusik attachments allow victims to be positioned various distances above rescuer depending on situational needs.

Disadvantages

- In steeper terrain, it becomes difficult to adjust the victim's position when they are dependant on the system to keep from falling.

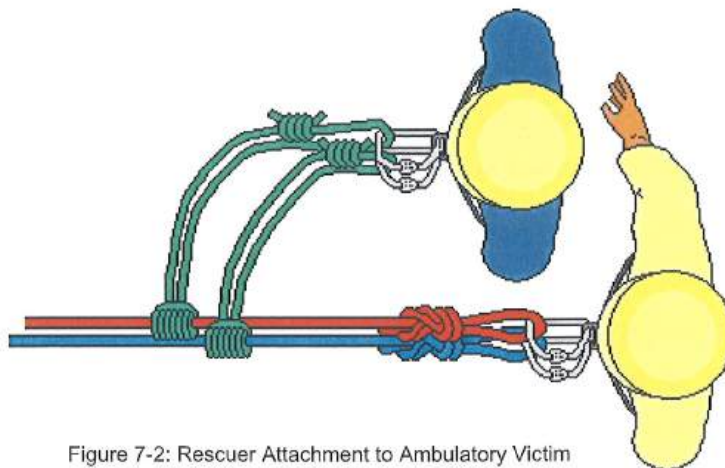

Figure 7-2: Rescuer Attachment to Ambulatory Victim

Rescue Litter Attachments to a Rope Rescue System

Litters are attached to the ends of the main line and the belay/safety line with head lashings. These lashings are constructed of either a 5-foot section of webbing or an 8-foot section of lifeline. Head lashings can be tied on scene or left pre-attached to the litter while in storage. These attachment points are for the commonly used rescue litters.

Constructing the Head Lashing (Figures 7-3 and 7-4)

- Wrap an open 5-foot length of webbing or an 8-foot length of lifeline around the main frame at the head of the rescue litter. Beginning outside one of the skids and ending outside the opposite skid. Some plastic bodied litters do not have skid rails. For these applications, the head lashing will be wrapped around the top handholds.
- Avoid the weld in the middle to prevent abrasion to the webbing or lifeline.
- Tie the webbing or lifeline into a loop with an overhand bend (webbing) or a double overhand knot (lifeline).
- Pull the webbing or lifeline from the center of the main frame (at the weld point) until it reaches the end of the sling.
- Rotate sling until knot is off to one side.
- The head lashing should be connected to a central small hole in a rigging plate with a NFPA General Use carabiner as shown.

Constructing the Head Lashing (Figure 7-5)

- Form one closed (tied) 5-foot sling on one side of the rescue litter around the handrail and main rib.
- Wrap a second closed 5-foot sling on the other side of the rescue litter in the same manner.
- Attach a carabiner to each of the slings.
- Attach both carabiners to the collection plate as shown.

Constructing the Head Lashing (Figures 7-6)

- Wrap an open 5-foot length of webbing or an 8-foot length of lifeline around the main frame at the head of the rescue litter. Beginning outside one of the skids and ending outside the opposite skid. Some plastic bodied litters do not have skid rails. For these applications, the head lashing will be wrapped around the top handholds.
- Avoid the weld in the middle to prevent abrasion to the webbing or lifeline.
- Tie the webbing or lifeline into a loop with an overhand bend (webbing) or a double overhand knot (lifeline).
- Pull the webbing or lifeline from the center of the main frame (at the weld point) until it reaches the end of the sling.
- Rotate sling until knot is off to one side.
- The head lashing should be connected with two NFPA General Use carabiners directly into both the main and safety/belay lines as shown.

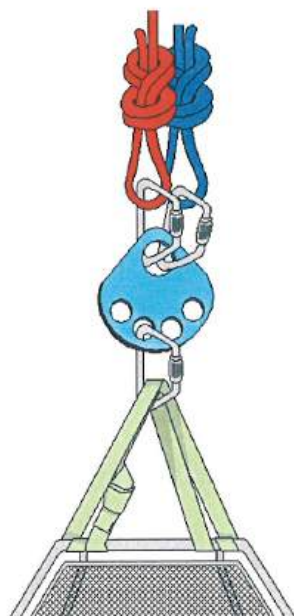

Figure 7-3: 5-foot Webbing

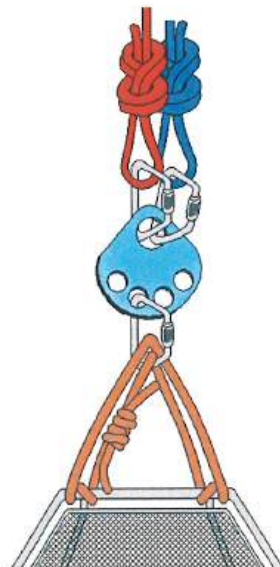

Figure 7-4: 8-foot Lifeline

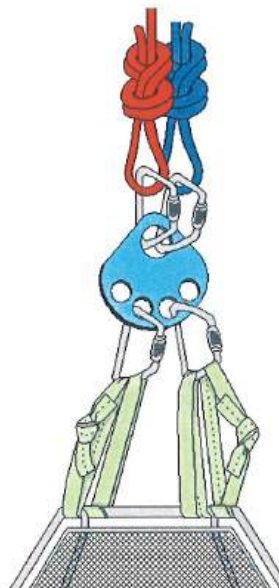

Figure 7-5: Pre-rig

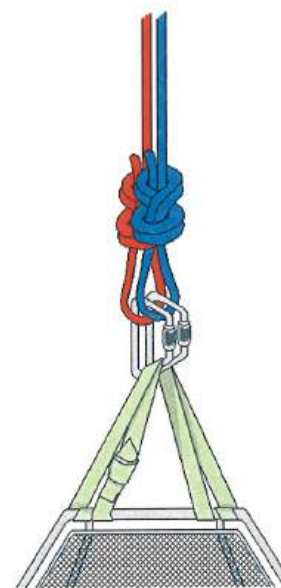

Figure 7-6: Without an anchor plate

	<i>Advantages of Each</i>	<i>Disadvantages of Each</i>
Figure 7-3	Compact, simple to tie, pre-rig, and attach.	Least strength.
Figure 7-4	Strong and abrasion resistant.	May be bulky to tie and attach to.
Figure 7-5	The webbing is backed up and separate.	Most complicated to construct.
Figure 7-6	Requires less equipment.	Difficult to modify configuration.

Rescuer Attachment to the Litter System

Rescuers are attached to the litter system using a litter harness pre-rig (pre-rig), made up of two bridles. The configuration of the pre-rig is determined by the number of rescuers used to support the litter. The use of a three- or four-rescuer configuration is determined by the victim weight and size, availability and strength of personnel, incline of slope, and type of terrain.

Litter Harness Pre-rig

The rescuers are attached to the litter with a litter harness pre-rig. A pre-rig is an adjustable pre-tied combination of lifeline, prusiks, and carabiners. It is used to connect the rescue lines, litter, and rescuers together. The adjustability of the pre-rig allows it to be used in low angle, high angle, or high line operations. A pre-rig consists of two bridles as shown in Figure 7-7.

Bridle Construction

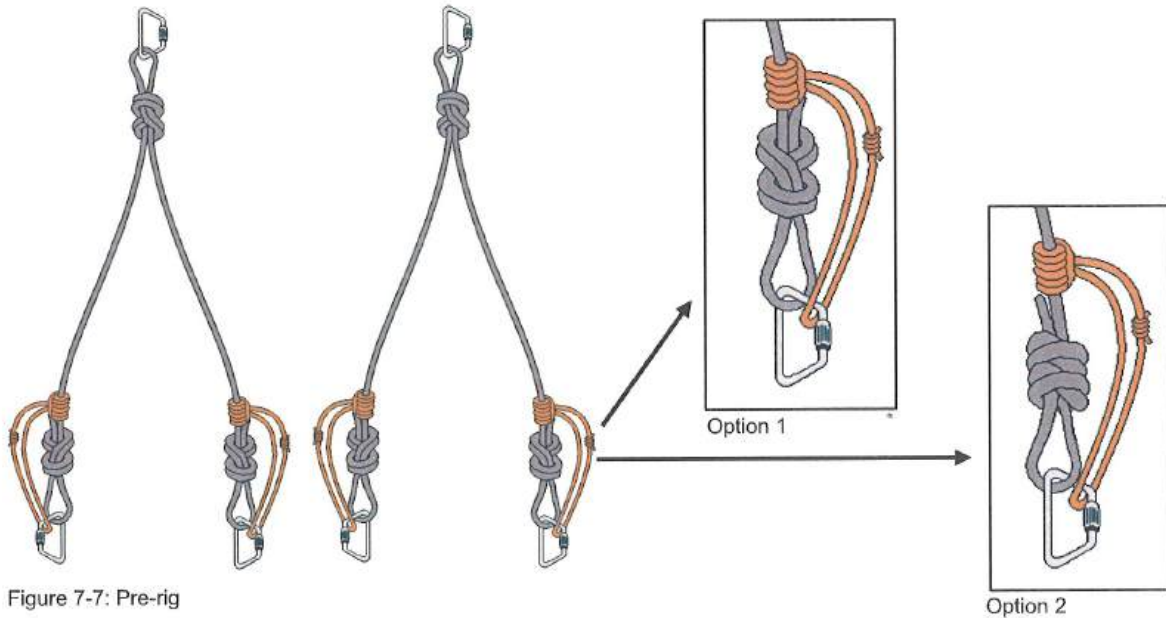

Figure 7-7: Pre-rig

- ❑ Tie a figure eight on a bight or a double overhand on a bight in the middle of a 16-foot section of lifeline and attach a NFPA General Use carabiner to this knot.
- ❑ Tie a figure eight on a bight into each end of the 16-foot section of lifeline and attach NFPA General Use carabiner to each knot.
- ❑ Attach a three-wrap prusik to each leg of the pre-rig and clip the prusik loop into the carabiner at the end of each leg.

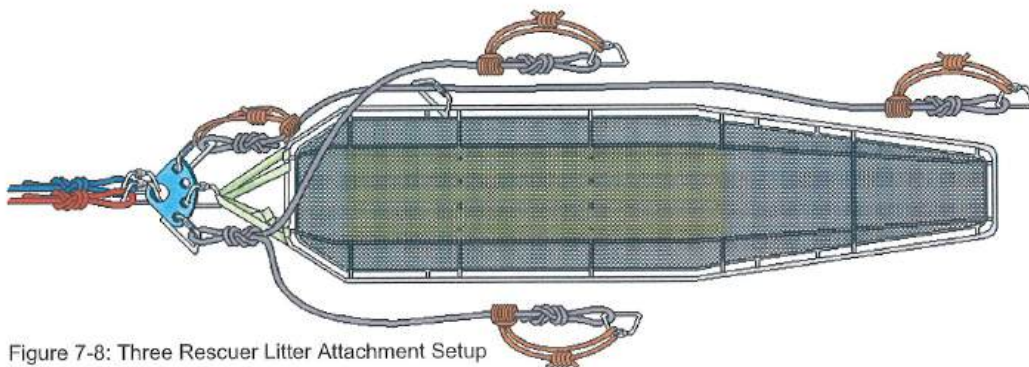

Figure 7-8: Three Rescuer Litter Attachment Setup

Three Rescuer Litter Attachment

In this orientation, the rescuers will be positioned as follows:

- One rescuer at the foot of the litter.
- One rescuer on each side of the litter located near the victim's shoulder.

Setup Specifics

- One pre-rig bridle is connected to an outside hole on the rigging plate with a carabiner at the midpoint knot.
- The second bridle of the pre-rig has the midpoint knot untied.
 - One end of the untied bridle is secured to the unused outside hole of the rigging plate.
 - The other end of untied bridle is placed near the foot of the litter.
 - This section of the bridle is attached to shoulder of the litter with the carabiner freed up from untying the midpoint knot. This helps keep the line clear of the victim.
- The three rescuers attach the front waist D-rings on their harnesses to the carabiner attached to the figure eight knot and prusik loop on the end of the pre-rigs.
 - They then slide the prusik along the pre-rig to position themselves.

Key Points

- The victim, personnel, slope, and terrain will determine the need for either three rescuers or four rescuers.

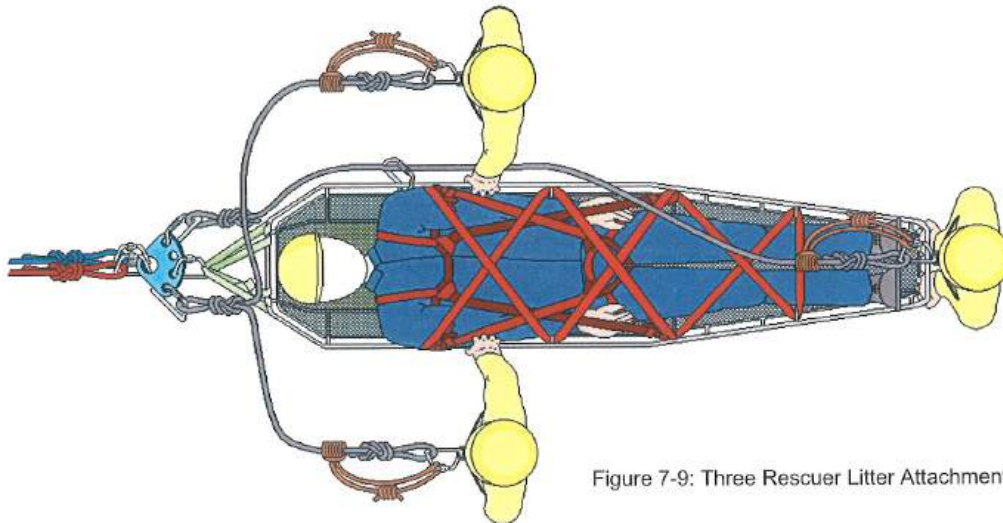

Figure 7-9: Three Rescuer Litter Attachment

Advantages

- Fewer personnel required.
- Less equipment necessary.
- Steep slopes place more of the victim's weight on the ropes.

Disadvantages

- Shallower slopes place more of the victim's weight on the rescuers.
- Difficult for Foot Person to see path of travel.

Four Rescuer Litter Attachment

In this orientation, rescuers will be positioned at the shoulders and the knees on each side of the litter.

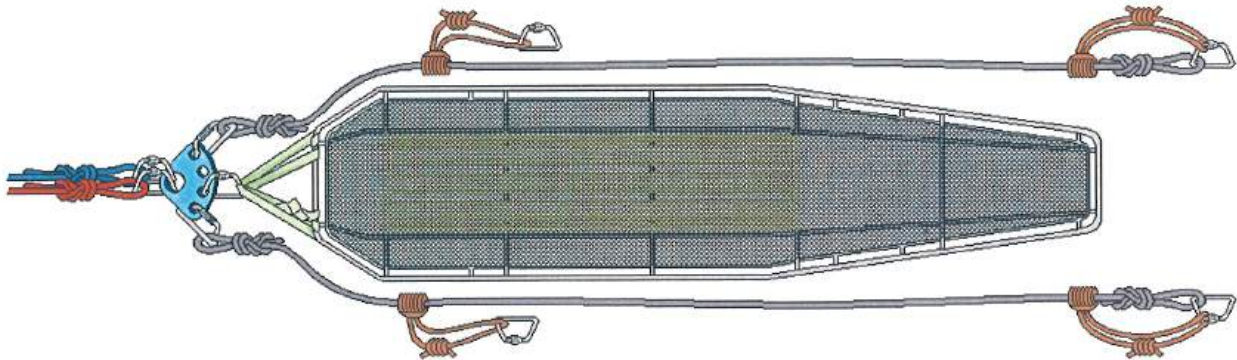

Figure 7-10: Four Rescuer Litter Attachment Setup

Setup Specifics

- Untie the midpoint knot from both bridles of the pre-rig after removing the carabiners.
- Attach the figure eight knot on the end of the bridle to an outside hole on the rigging plate.
- Extend the bridle along the side of the litter so that the figure eight knot on the opposite end of the bridle from the rigging plate is at the foot of the litter.
- Detach the prusik loop from the bridle carabiner at the rigging plate and slide the prusik down the bridle to the shoulder of the litter.
- Attach the carabiner removed from the midpoint knot to this prusik.
- Repeat above steps with the second bridle on the other side of the litter.
- Rescuers at the shoulders will attach the front waist D-rings on their harnesses to the prusik loop at the shoulders of the litter and position themselves by adjusting the prusiks.
- Rescuers at the knees of the litter will attach the front waist D-ring of their harnesses to the carabiner attached to the figure eight knot and prusik loop on the end of the bridle. They will position themselves by sliding the prusik up as needed.

Key Points

- The victim, personnel, slope, and terrain will determine the need for either three rescuers or four rescuers.

Advantages

- More rescuers to support the victim's weight on shallower slopes.
- All personnel can see terrain for footing.

Disadvantages

- More personnel required.
- More equipment required.
- Greater load applied to the system than 3-person.

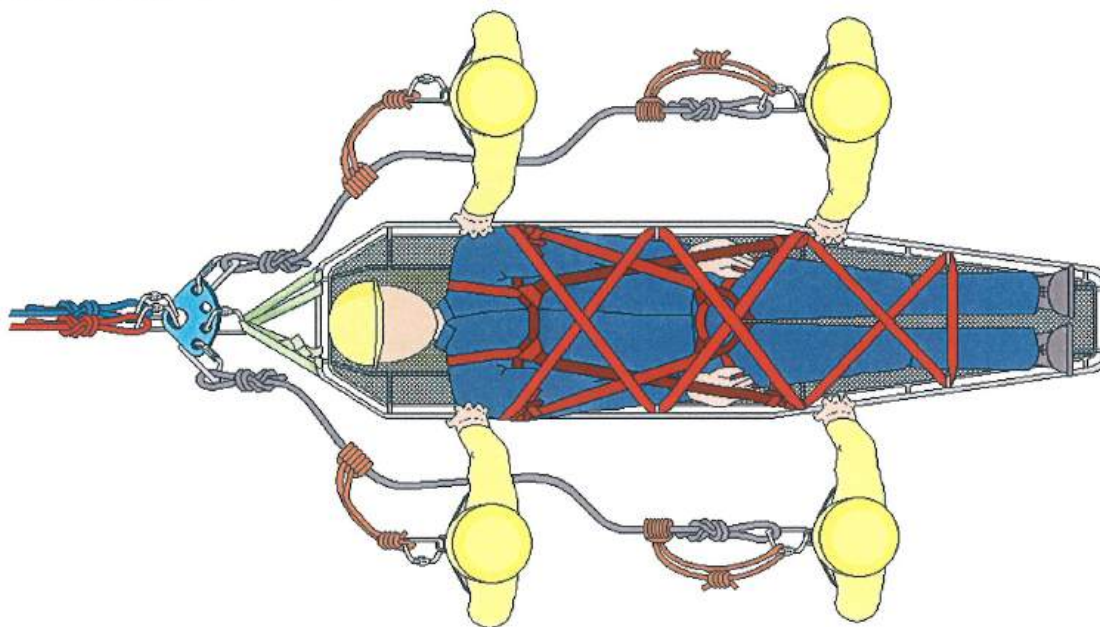

Figure 7-11: Four Rescuer Litter Attachment

Fall Restraint

Personnel exposed to a potentially hazardous fall should be protected with a fall restraint system. A fall restraint system is assembled to prevent the rescuer from falling off an edge. The purpose of a fall restraint system is to prevent injury by limiting the distance a person can fall while still allowing the necessary degree of movement to perform their assignment. The fall restraint system consists of an anchor, approved harness, lifeline, and related hardware and software adjusted to limit the potential fall to two (2) feet.

Standard

The standard that governs fall protection is in Title 8 of the California Code of Regulations, §1670. This standard specifically defines industry standards for the construction industry. These standards may not be applicable to fire and rescue emergency operations.

Considerations

When should a fall restraint system be attached to a rescuer working on or near an edge in a low angle operation?

- ① Always make this consideration.
- ② Is there a real potential for a rescuer to fall? An example would be a rescuer assigned to manage rope protection that is positioned at the edge of a steep, slippery bank.

- ③ Will fall restraint lines create more hazard potential than protection potential for the rescuer?
- ④ When the Safety Officer and/or an appointed lookout is not available to provide visual supervision to keep rescuers from moving in and out of fall-risk areas.
- ⑤ Continue to evaluate the scene as the operation progresses.

Components of a Fall Restraint System

- An adequate anchor that is able to support a single-person load and in line with the working area and the rescuer to be restrained.
- An appropriate length of lifeline attached to the anchor and rescuer.
 - At the most 2 feet of extra line beyond the edge.
 - With a device or mechanism of adjusting the length at one or both ends of the line.
 - Having adjustment mechanisms at both ends of the system allows large adjustments to be made at the anchor end and fine adjustments to be made at the rescuer's end.
 - ♦ This allows fine-tuning of the line length by the rescuer while limiting the potential for extra rope to gather near the rescuer's feet, creating a tripping hazard.

How to Construct a Fall Restraint System

- Identify the anchor point to be used.
 - If the anchor is a picket, drive it into the soil with the proper angle to the load.
- Tie a figure eight on a bight on one end of the lifeline and toss it from a safe distance to the edge of the bank.
- Extend the line to the anchor.
- Attach the line to the anchor using either of the following methods.

Using a Picket

This method reduces the equipment needed to a picket and a lifeline.

- Form a clove hitch over the picket.
- Pay out 3 feet of slack from behind the knot.
- Form a figure eight on a bight and place it over the picket.
- The clove hitch can be used for adjustment.
- The figure eight on a bight is a backup to the clove hitch.

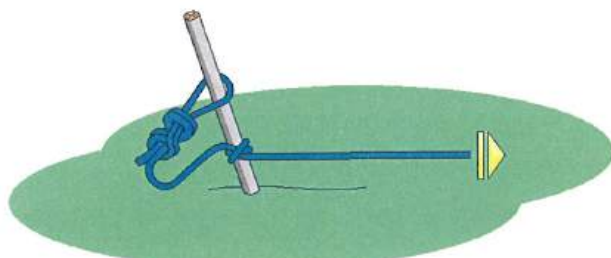

Figure 7-12: Using a Picket

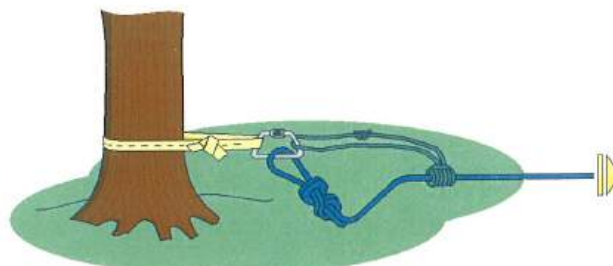

Figure 7-13: Other than a Picket

Using an Anchor Other than a Picket

This method can also be used with a picket anchor.

- Attach a sling and carabiner to the selected anchor.
- Form a three-wrap prusik on the line and attach it to the carabiner on the anchor sling.
- Pay out 3 feet of slack from behind the prusik and tie a figure eight on a bight.
- Attach the figure eight on a bight to the carabiner on the anchor sling.
- The prusik can be used for adjustment.

How to Construct a Fall Restraint System – Rescuer Connections

- Retrieve the end of the rope with the figure eight on a bight from the edge.
- Attach the end of the line to the rescuer using either of the following methods.

Direct, Nonadjustable Attachment

This method uses the least amount of equipment to connect and results in less slack line to maintain, reducing tripping hazards.

- Attach the figure eight on a bight knot in the end of the fall restraint line to the rescuer's harness with a carabiner.
 - Attachment can be made to either the front or rear D-ring attachment on the harness.

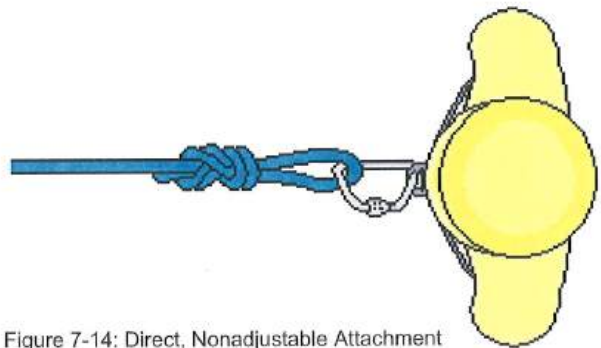

Figure 7-14: Direct, Nonadjustable Attachment

Adjustable Attachment

- Place a three-wrap prusik just behind the figure eight on a bight in the end of the fall restraint line.
- Attach a carabiner to both the figure eight on a bight and the prusik.
- Connect the carabiner to the front D-ring on the rescuer's harness.
- The prusik allows the rescuer to make his or her own adjustments as needed.

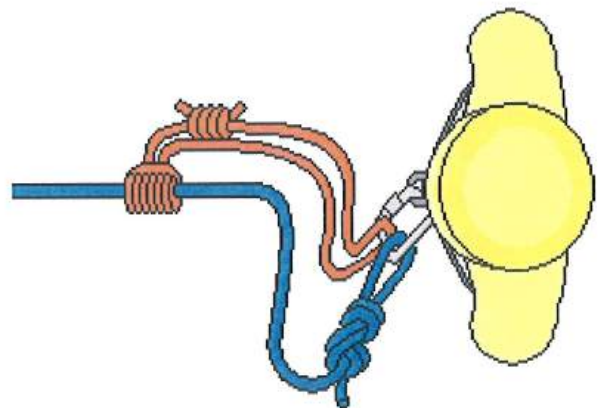

Figure 7-15: Adjustable Attachment

Chapter 8: Three Main Components of a Rope Rescue System

Scope: This chapter serves as an orientation to the three main components of a rope rescue system.

Terminal Learning Objective (TLO): At the end of this chapter, the student will be aware of rope rescue system construction requiring the assembly of individual items (rescue rope and related equipment) into functional components.

Enabling Learning Objectives (ELO):

1. Define key points about the component approach
2. Demonstrate a single RPM configuration
3. Demonstrate a prerigged dual RPM system

The construction of rope rescue systems requires the assembly of individual items (rescue rope and related equipment) into functional components that when put together form operating systems. Traditionally these individual items have been stored and transported as a cache of equipment grouped by like items to the rescue scene. Rescuers then assemble these individual items into components, and then into working systems. At best, this is not a timely or efficient approach to bring to the rescue scene.

Grouping these individual items into component systems, and prepackaging them into a standardized system will greatly reduce set-up time and simplify the construction and safe operation of low angle rope rescue systems. Local and regional standardization based on this concept will help ensure smooth interagency operations of these types.

This manual identifies three main components of low angle rope rescue operations.

1. **Belay/Safety Line Component**
2. **Main Line Component:** Can function as a lowering line, raising line, or fixed line for rappelling.
3. **Mechanical Advantage Component:** Can be independent or part of the main line.

Key Points about the Component Approach

- The basic system requires two lifelines: one to support a belay/safety line component and another to support a main line component.
- These two components can each be preassembled and carried on an apparatus, ready to be put into immediate service.
- The belay/safety line component is the back up to all other components of any rope rescue system in the event of its failure. This line will be loaded only if there is a failure in the main line system.
- The main line component carries the load in all rappel, lower, and raise operations. The main line component will convert into a part of the mechanical advantage or haul line system depending on what type of mechanical advantage is constructed.
- A main line component that carries a collection of equipment that includes a descent control device, pulley, and load-releasing device with one or two prusiks is commonly referred to as a **RPM**. The "**R**" refers to resistance, meaning a figure of eight descender or brake bar rack. The "**P**" refers to a pulley. The "**M**" refers to a Mariner's hitch, an early form of load releasing device.

- The mechanical advantage component is the minimum equipment required to construct any of the mechanical advantage systems shown in this manual. This equipment is commonly carried in the main line component rope bag equipment pocket or a separate equipment bag.

Belay/Safety Component



Figure 8-1

Function: This component will provide fall arrest for rescuers and victims and shall be included in all systems. Staffing this component shall be the sole responsibility of a competent individual.

Minimum equipment:

- LRD
- Two carabiners
- One short prusik
- One long prusik

May be stand-alone or part of an RPM.

Main Line Component (RPM)



Figure 8-2

Function: This component will provide lowering capabilities for rescuers and victims during system operations. During lowering operations, the braking components (tandem prusiks) will be optional.

Minimum equipment:

- Anchor plate
- Descent control device
- Pulley
- LRD
- One short prusik
- One long prusik
- Five carabiners

Mechanical Advantage Component

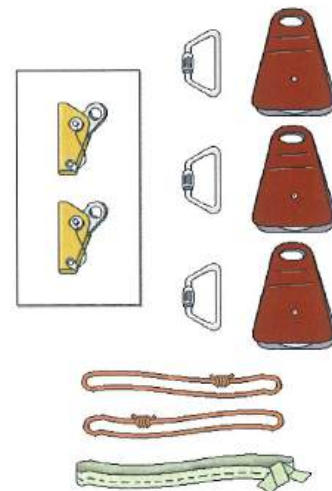

Figure 8-3

Function: To provide raising capabilities for rescuers and victims during system operation. During raising operations, the braking component will be required.

Minimum equipment:

- Three carabiners
- Three pulleys
- Two short prusiks or mechanical rope grabs
- One anchor sling (5' – 20') as needed

Supports the construction of 3:1 or 5:1 mechanical advantage systems.

Prerigged Dual RPM Systems

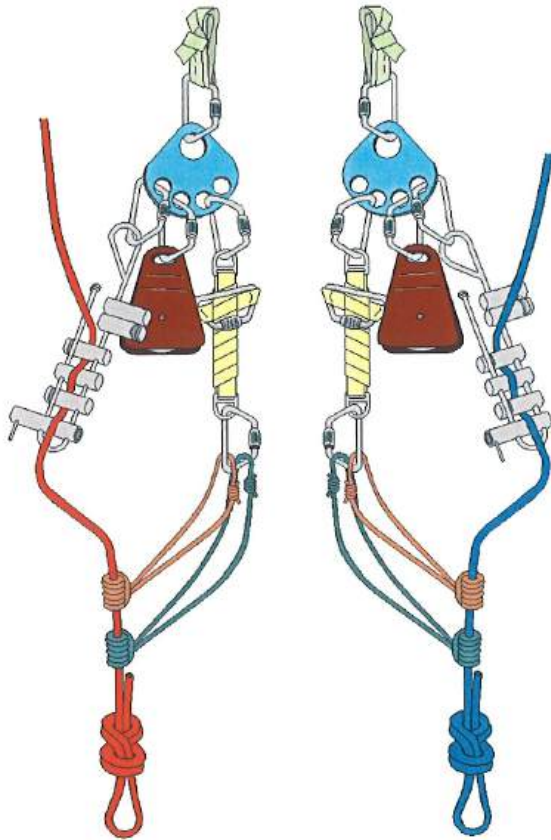

Figure 8-6: With Brake Bar Rack

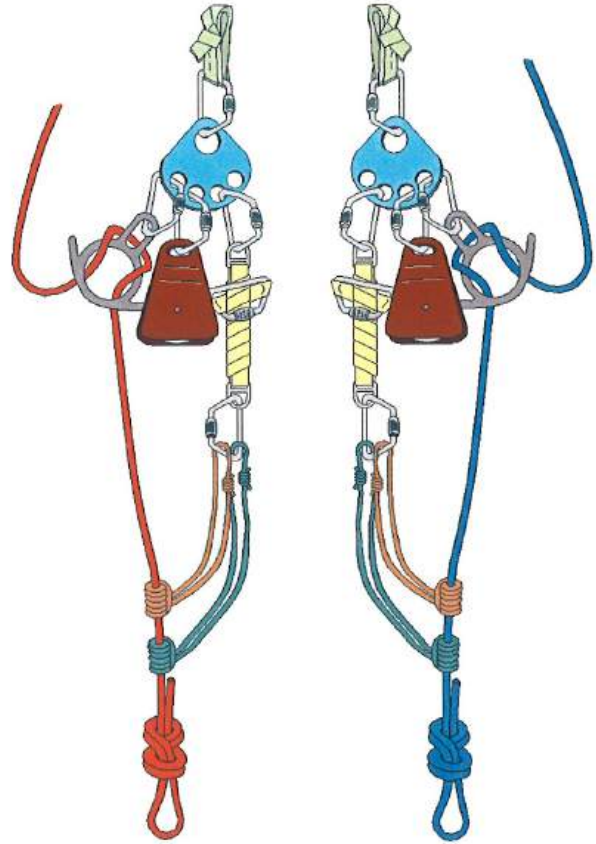

Figure 8-7: With Figure Eight Descender

- Prerigged dual RPMs with tandem prusiks are a common rural configuration where low angle rope rescue operations are most often, if not exclusively, utilizing a directional change pulley off the collection plate.
- When attached to anchors, the RPMs are configured with the load-releasing devices (LRDs) to the inside and adjacent as shown.
- This configuration is ideal for lower/raise operations in environments with a limited operating distance between the main anchor and the working edge. This is a common scenario in over the bank operations on narrow roadways.
- Either RPM can become the belay/safety or main line side of the system based on site specifics and operational needs.
- The equipment required for the construction of the mechanical advantage system is commonly carried in a pocket in one of the two rope bags, bagged separately, or preassembled and attached to a lifeline in a separate rope bag. (Figure 8-3)

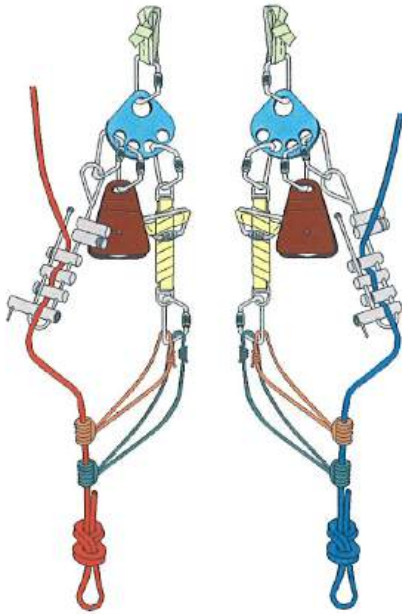

Figure 8-8: With Brake Bar Rack: As Stored

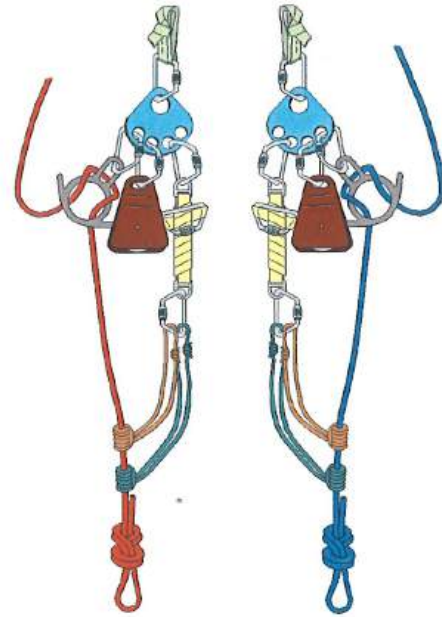

Figure 8-9: With Figure Eight Plate: As Stored

- Redundant RPM systems are stored in the configurations above.
- This allows for the use either as a belay/safety line or main line.

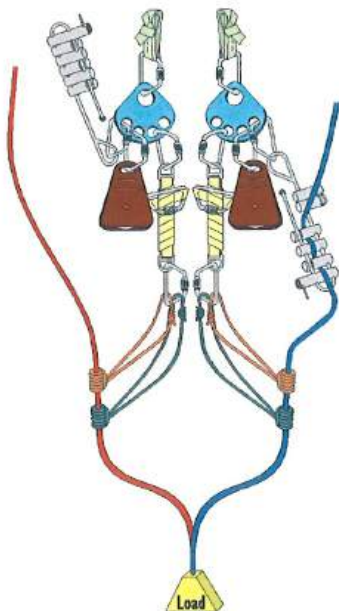

Figure 8-10: With Brake Bar Rack: In-service Lower

The main/lowering line tandem prusiks are optional during lowering operations.

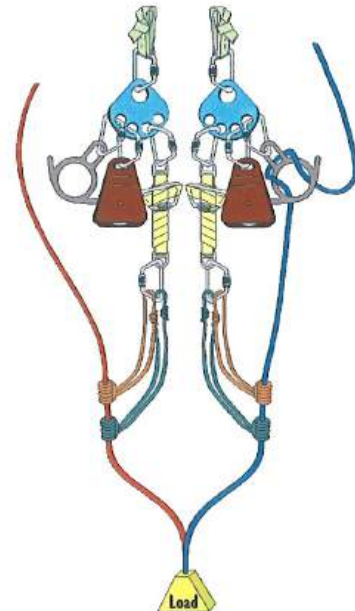

Figure 8-11: With Figure Eight Plate: In-service Lower

- To place the system in-service, the belay/safety line is removed from the descent control device.
- If the prusiks are left in-service for lowering, a main line brake tender is **required**.

Chapter 9: Belay/Safety Line Systems

Scope: This chapter serves as an introduction to belay/safety line systems.

Terminal Learning Objective (TLO): At the end of this chapter, the student will be aware of the importance of utilizing a back-up line to catch the load in the event of a failure of the main line.

Enabling Learning Objectives (ELO):

1. Define key points regarding the operation of a belay/safety line system
2. Demonstrate belay/safety line configurations
3. Demonstrate lowering operations – basic configuration
4. Demonstrate retrieval operations – basic configuration
5. Demonstrate lowering operations – PMP configuration
6. Demonstrate retrieval operations – PMP configuration
7. Describe system variations

In all emergency operations, the words "Safety First" need to be more than a catchy phrase. Rope rescue operations are no exception to this rule. An important part of ensuring safety is the utilization of a back-up line to catch the load in the event of a failure of the main line.

Many teams refer to this back-up line as the "belay line." This is a mountaineering term meaning, "To hold fast or provide security."

Other teams refer to this line as the "safety line." With this orientation, the term "Safety First" can provide a verbal reference to the back-up line and reinforce the concept of staffing, checking, and attaching the safety line first in all operations.

This manual will use both terms with the understanding that local agencies will use one or the other as their reference. With that being said, the belay/safety line systems and operations that are presented here *must be followed without exception*.

Key Points Regarding the Operation of Belay/Safety Line Systems

- The entire operation is only as safe as the belay/safety line system, its anchor, and its operator.
- Personnel staffing the belay/safety line must have sound operational skills. These skills are perishable and their maintenance requires regular hands-on practice under the supervision of a qualified person.
- Communication is essential during the operation of these systems.** The "edge" position is a critical link in the safe operation of the belay/safety line system. The edge person will communicate to the belay/safety line tender the amount of line and speed needed to accommodate the rescuer's needs. On occasion, the rescuer may need to move rapidly over an area. **The edge person will direct the belay/safety line tender regarding the operation of the system during these situations.**
- The Technical Safety Officer or Rescue Group Supervisor may fill the roll of "edge" as dictated by staffing and operational needs.
- Rope rescue operations are a go only when the "edge" position is filled.**

Belay/Safety Line Configurations

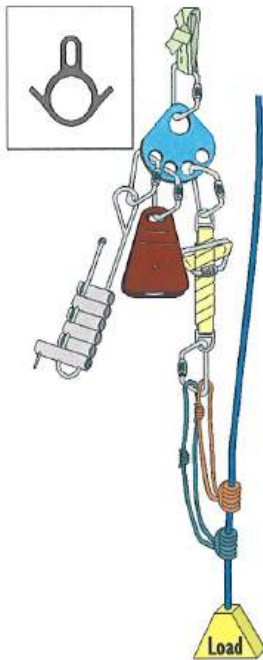

Figure 9-1: Basic Configuration

The basic belay/safety line configuration does not utilize the prusik minding pulley. This configuration does not provide for rapid retrieval of an unloaded line, however, it will allow the tender better "feel" of systems operation.

This configuration will minimize the potential of prusiks to grab or jam. The basic belay/safety line configuration also reduces the potential for damage to system components (line and prusiks) caused by the heat of friction. The potential for system problems associated with the use of the prusik minding pulley in the systems is eliminated.

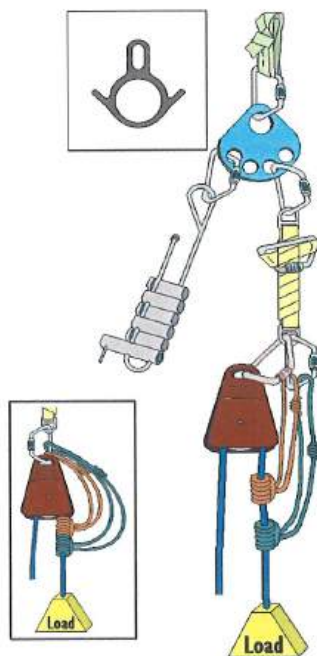

Figure 9-2: PMP Configuration

The prusik minding pulley (PMP) allows the belayer to retrieve the belay/safety line with hand over hand motion. This provides a quick method of retrieving a line that has been disconnected from the load.

This configuration can also be used while retrieving a belay/safety line during raising operations. The operator must ensure that the proper amount of tension is maintained in the prusik hitches around the belay/safety line. Excessive grip of the prusik to the line will cause the tandem prusiks to jam and/or be damaged due to the heat of friction.

Extreme caution must be used if utilizing this system to protect the load during lowering operations. The weight of the additional hardware can cause the tandem prusiks to grab unexpectedly. The system may be placed flat on the ground to prevent this. Prusik hitches that are too loose or improperly tended will not arrest a fall.

Lowering Operations – Basic Configuration

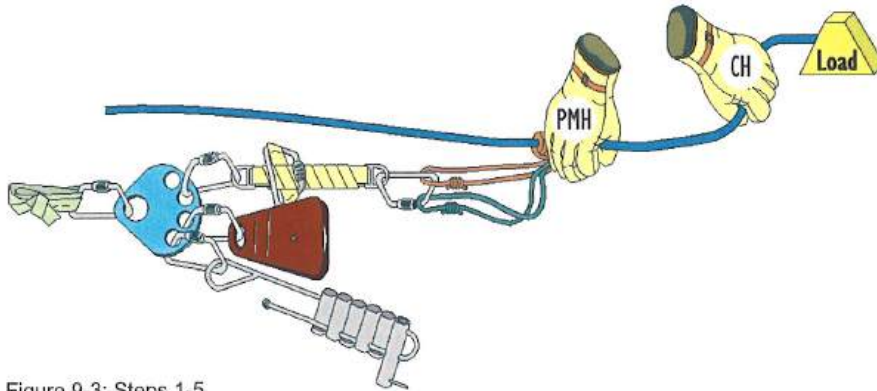

Figure 9-3: Steps 1-5

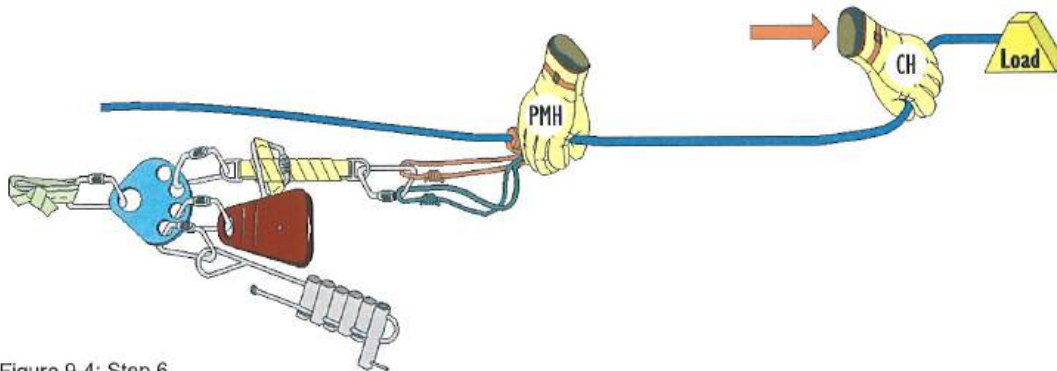

Figure 9-4: Step 6

- 1) **Prusik Minding Hand (PMH)** – Form a circle with the index finger and thumb around the line and against the load side of the long prusik.
- 2) **Control Hand (CH)** – Grasp the line on the load side of the tandem prusiks.
- 3) **Control Hand** – Angle the line with the hand as shown.
- 4) **Prusik Minding Hand** – Slide the long prusik toward the anchor until it contacts the short prusik and rest the remaining fingers of the **prusik minding hand** on the short prusik.
- 5) **Prusik Minding Hand** – Slide the tandem prusiks toward the anchor to develop 2"–3" of slack.
- 6) **Control Hand** – As the load moves away from the anchor, pull the line through the tandem prusiks to maintain less than 2 feet of slack in the line.
- 7) **Control Hand** – When arm's length is reached, repeat Step 6.

When pull straightens the angle at the control hand, set the prusiks unless otherwise directed.

Tandem prusiks are commonly set by "throwing" them towards the load with the prusik minding hand.

Retrieval Operations – Basic Configuration

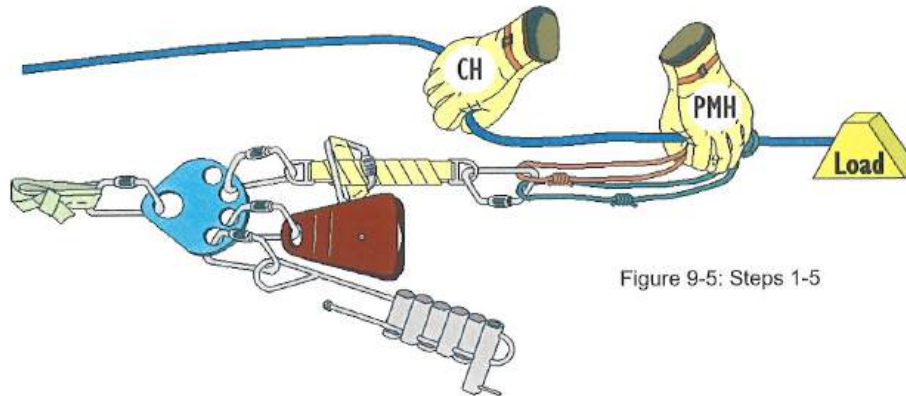

Figure 9-5: Steps 1-5

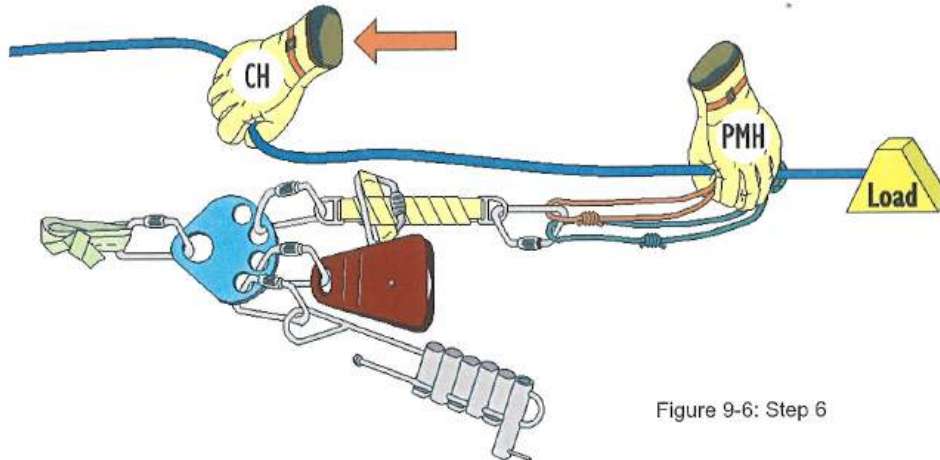

Figure 9-6: Step 6

- 1) **Prusik Minding Hand** – Form a circle with the index finger and thumb around the line and against the anchor side of the short prusik.
- 2) **Prusik Minding Hand** – Short prusik remains taut throughout the operation.
- 3) **Control Hand** – Grasp the line on the anchor side of the tandem prusiks.
- 4) **Control Hand** – Angle the line with the hand as shown.
- 5) **Control Hand** – As slack develops during retrieval, pull the line through the tandem prusiks to maintain a taut line.
- 6) **Prusik Minding Hand** – As the line is retrieved by the control hand, the long prusik will move to contact the short prusik. Rest the remaining fingers of the **prusik minding hand** on the long prusik.
- 7) **Control Hand** – When arm's length is reached, repeat Steps 3, 4, and 5.

When direction of travel reverses, properly tended prusiks will set.

Tandem prusiks are commonly set by "throwing" them towards the load with the prusik minding hand.

Lowering Operations – PMP Configuration (Optional)

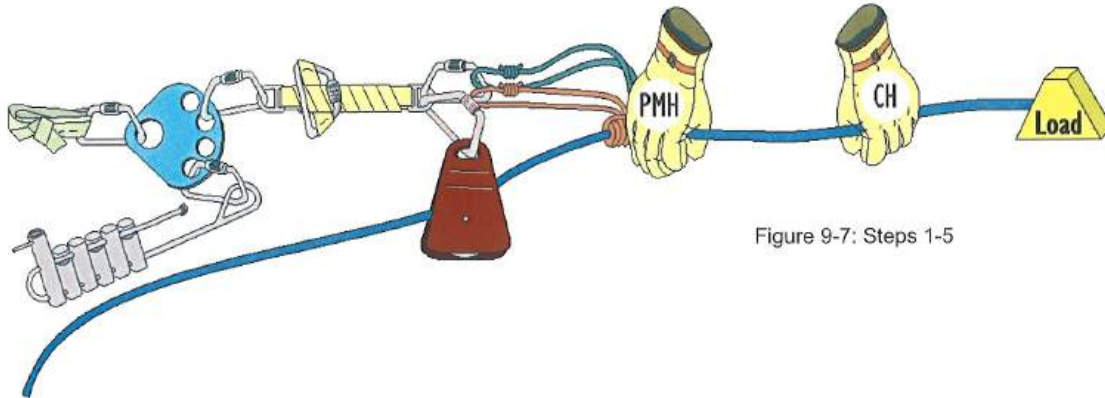

Figure 9-7: Steps 1-5

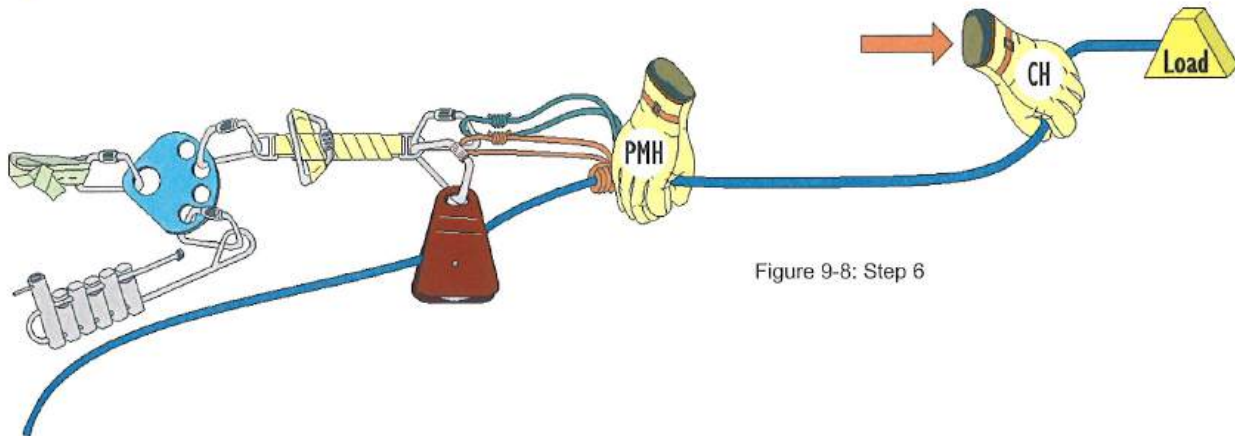

Figure 9-8: Step 6

If possible, open the angle of the line in the pulley as shown. This will allow the line to feed through the system more easily.

- 1) **Prusik Minding Hand** – Form a circle with the index finger and thumb around the line and against the load side of the long prusik.
 - 2) **Control Hand** – Grasp the line on the load side of the tandem prusiks.
 - 3) **Control Hand** – Angle the line with the hand as shown.
 - 4) **Prusik Minding Hand** – Slide the long prusik toward the anchor until it contacts the short prusik and rest the remaining fingers of the **prusik minding hand** on the short prusik.
 - 5) **Prusik Minding Hand** – Slide the tandem prusiks toward the anchor to develop 2" – 3" of slack.
 - 6) **Control Hand** – As the load moves away from the anchor, pull the line through the tandem prusiks to maintain less than 2 feet of slack in the line.
 - 7) **Control Hand** – When arm's length is reached, repeat Step 6.
- When pull straightens the angle at the control hand, set the prusiks unless otherwise directed. Tandem prusiks are commonly set by "throwing" them towards the load with the prusik minding hand.

Retrieval Operations – PMP Configuration (Optional)

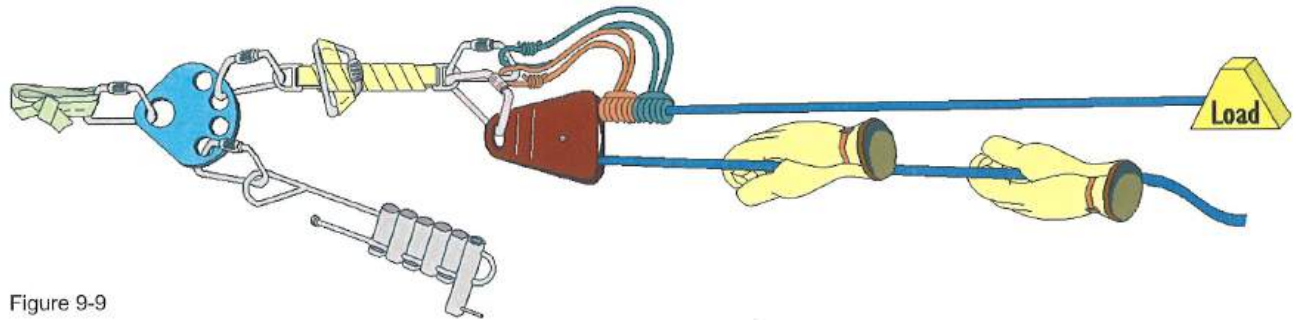

Figure 9-9

- 1) With one hand, grasp the line on the side opposite the tandem prusiks 2 feet below the pulley.
- 2) With the other hand, grasp the line on the same side of the pulley a comfortable distance away from the first hand.
- 3) Pull the line hand-over-hand, away from the anchor.

Key Points

- Maintain a two-foot spacing between hands and pulley to avoid possible entanglement in pulley.
- The line must be maintained at 180° in and out of the prusik minding pulley.
- Prusiks must ride squarely on the bottom edge of the pulley.
- Prusiks allowed to ride up the side of the pulley may jam or be damaged by the heat of friction.
- When direction of travel reverses, the prusiks will set.

System Variations

It is common to see the basic belay/safety system configuration utilized during lowering operations and the belay/safety line system with the prusik minding pulley utilized during retrieval operations.

Dual RPMs Configuration

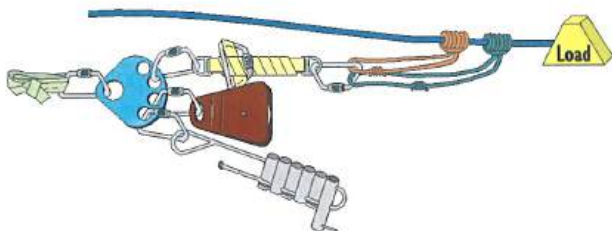

Figure 9-10: Basic Configuration – Lower

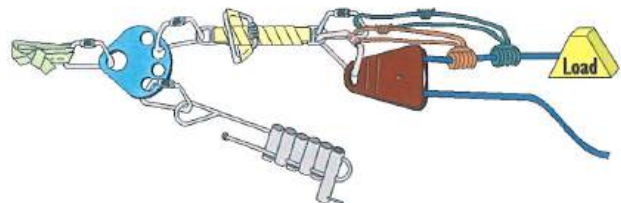

Figure 9-11: PMP Configuration – Retrieve

Belay/Safety Line Single Configuration (as shown in Chapter 8)

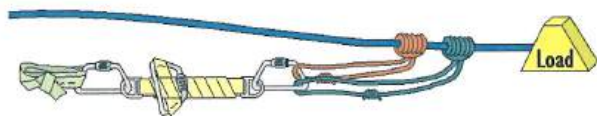

Figure 9-12: Single Configuration without PMP

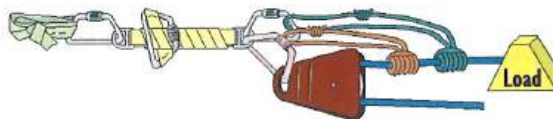

Figure 9-13: Single Configuration with PMP

Key Points

- A belay/safety line system shall be utilized any time a main line is used (two line systems).
- The belay/safety line system is the most critical part of any rope system as it provides for fall arrest in the event of main line system failure.
- The operation of this system is a critical skill requiring a high degree of knowledge and understanding.

Chapter 10: Descending/Ascending

Scope: This chapter serves as an introduction to descending and ascending techniques and the use of descent control devices.

Terminal Learning Objective (TLO): At the end of this chapter, the student will be aware how to complete a slow, steady descent and then ascend under controlled conditions.

Enabling Learning Objectives (ELO):

1. Describe ascending and descending techniques
2. Demonstrate how to construct a fixed line for a rappel
3. Demonstrate how reeve a figure eight descender and brake bar rack
4. Demonstrate a rappel and lock-off using a figure eight descender and brake bar rack
5. Demonstrate how to ascend a fixed line and escape jammed friction devices

Descending

Descending, or what is more commonly referred to as rappelling, is a seldom used element of low angle rope rescue. In most situations, it is better to lower rescuers to an incident; however, on occasion, a rescuer needs to rappel to access the site. For instance, a fixed (rappel) line may be necessary when multiple rescuers are needed quickly at the bottom of a slope. Rappelling is a valuable skill that teaches the use of different rescue equipment and builds confidence in the rescuer's ability, equipment, and team capability. Rappelling is a dangerous activity, however, and must be completed under controlled conditions. A proper rappel is a slow, controlled walk down the slope. A slow, steady descent is much easier on ropes and anchors and prevents serious heat buildup from friction that can damage nylon ropes. A fast, bounding rappel has no place in the rescue service and only serves to overheat the descent control device (DCD) and shock load the anchors and their components.

Types of Descent Control Devices (DCD)

Figure Eight Descender (Eight Plate)

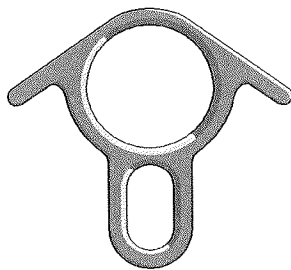

10-1: With Long Ears

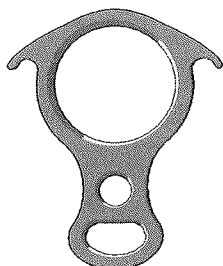

10-2: With Short Ears

Brake Bar Rack

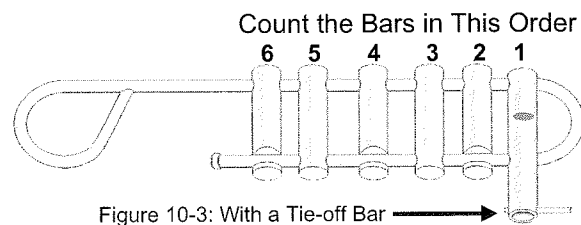

Figure 10-3: With a Tie-off Bar

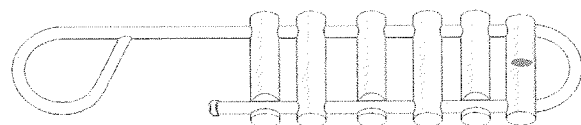

Figure 10-4: Without a Tie-off Bar

Rigging a Fixed Line

- Attach a RPM to a suitable anchor.
- Always tie a figure eight stopper knot in the end of any rappel line.
 - This reduces the potential for rappelling off the end of the line.
- Pay out enough line to reach the desired location.
- Reeve line through the DCD on the RPM.
 - Maintain a minimum 20-foot tail in the fixed line.
 - Lock-off the DCD (illustrated later in this chapter).
 - Form a figure eight on a bight with the tail near the DCD and clip onto the open hole of the anchor plate using a separate carabiner, maintaining 2 feet of slack.

Belay/Safety Line

- The anchor must be located inline with the main line.
 - This prevents a pendulum action if the main line fails.
- Construct a belay/safety line system.

Line Attachments

The rescuer dons a pelvic harness, positions a safe distance from the edge, and faces the anchor with the fixed/rappel line on the right side. The belay/safety line and DCD should attach to separate carabiners at the rescuer's harness.

- Belay/safety line.
 1. Tie a figure eight on a bight in the end of the belay/safety line.
 2. Attach the figure eight on a bight to the rescuer's harness.
- Fixed/rappel line.
 1. Reeve DCD.
 2. Ensure DCD is secured to the rescuer's harness.

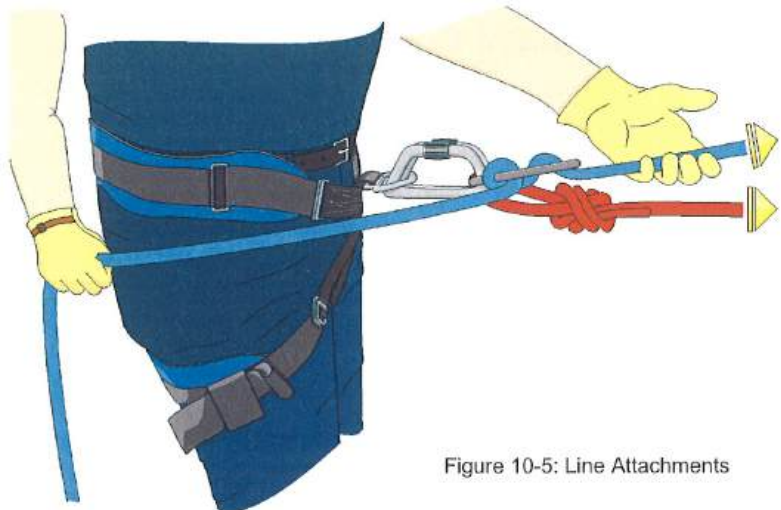

Figure 10-5: Line Attachments

Figure 10-5 depicts the rescuer with main line and belay/safety line attachments. The remaining graphics have the belay/safety line omitted for clarity.

Reeve the Figure Eight Descender

The figure eight descender is shown being reeved for right-handed operation. For a left-handed rescuer, the belay safety line carabiner must be attached to the right side of the figure eight carabiner. Attention must be given to keeping the belay/safety line running clear of the main line. It is because of this potential problem that some agencies encourage or require right-handed operations in rappelling evolutions.

1. Form a bight in the fixed line and pass it toward you through the large hole.
 - Some agencies may choose to pass the bight through the opposite direction. This will affect the lock-off procedures described later in this chapter.

Figure 10-6: Step 1

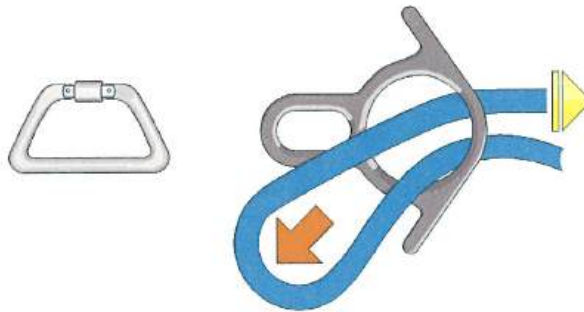

2. Pull the bight through and pass it over the smaller portion of the descender.

Figure 10-7: Step 2

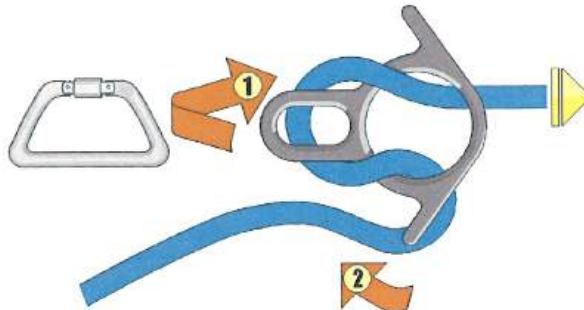

3. Attach the figure eight descender to the harness with a carabiner.

Figure 10-8: Step 3

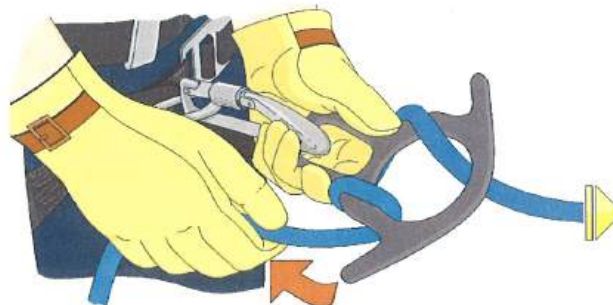

Reeve the Brake Bar Rack

1. Attach the brake bar rack to the harness with a carabiner.

Figure 10-9: Step 2

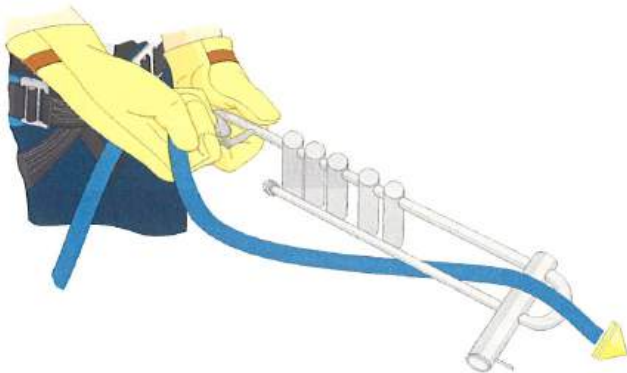

2. Lay the fixed line in the groove on the first bar on the rack.

- Allow the line to pass through the opening of the rack.

Figure 10-10: Step 3

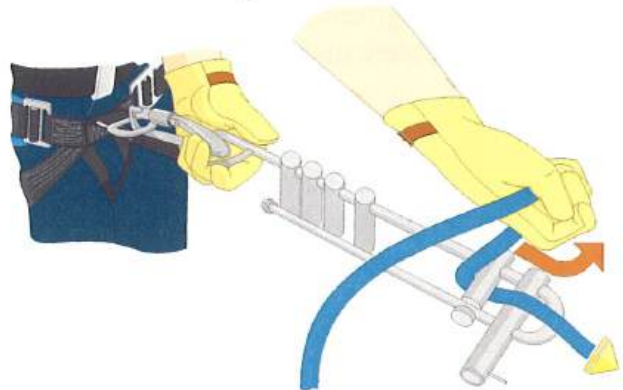

3. Flip the second bar over and snap it onto the rack with the line between the first and second bars.

- Pull the line back through the opening of the rack, wrapping the second bar.

Figure 10-11: Step 4

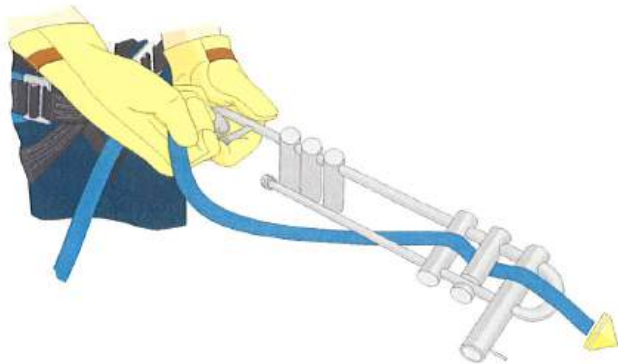

4. Flip the third bar over and snap it onto the rack with the line between the second and third bars.

- Pull the line back through the opening of the rack, wrapping the third bar.

Figure 10-12: Step 5

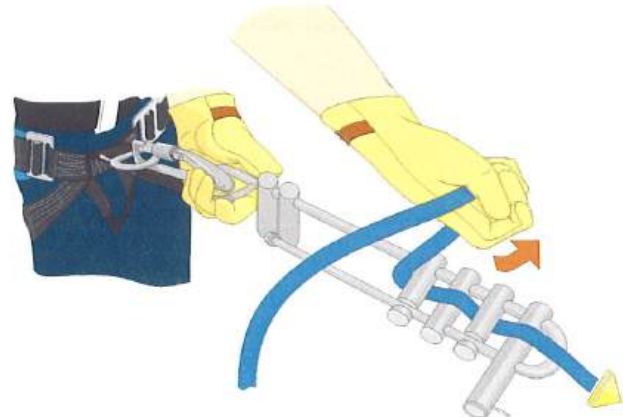

5. Repeat until the desired amount of bars/friction has been achieved.

- Friction may be adjusted during the descent by adding or removing bars.
 - Four bars minimum for one (1) person.
 - Five bars minimum for two (2) or more people.

Rappel Position

The rescuer's lower body should always be perpendicular to the slope, with both feet flat on the surface, in order to maintain footing and tension on the system. This perpendicular position needs to be maintained if there is any change in the angle of the slope during the descent.

Hand Position

The hand position changes depending on the DCD.

Figure Eight Descender

- ☐ Brake hand.
 - Grasps the rope.
 - Pulls it tight around the hip.
 - Holds it tight with the fist positioned at the buttocks.
- ☐ Control hand.
 - Positioned either in front of the descender or just below it to help control the body posture.
 - This is considered to be the full brake position.
 - The friction can be decreased by moving the braking hand away from the buttocks and hip while stepping backwards until the desired speed is achieved.

Figure 10-13: Rappel Position

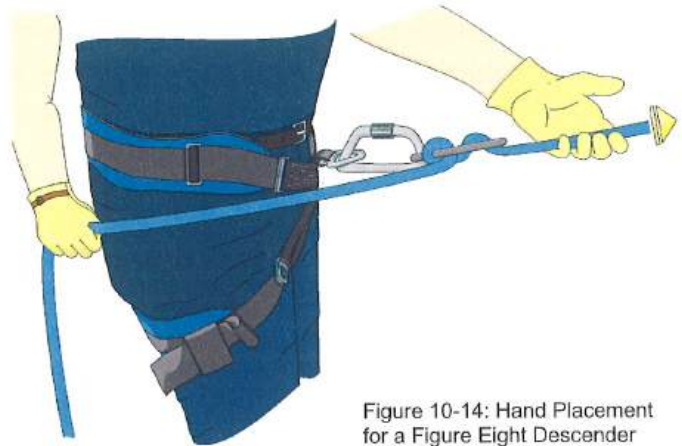
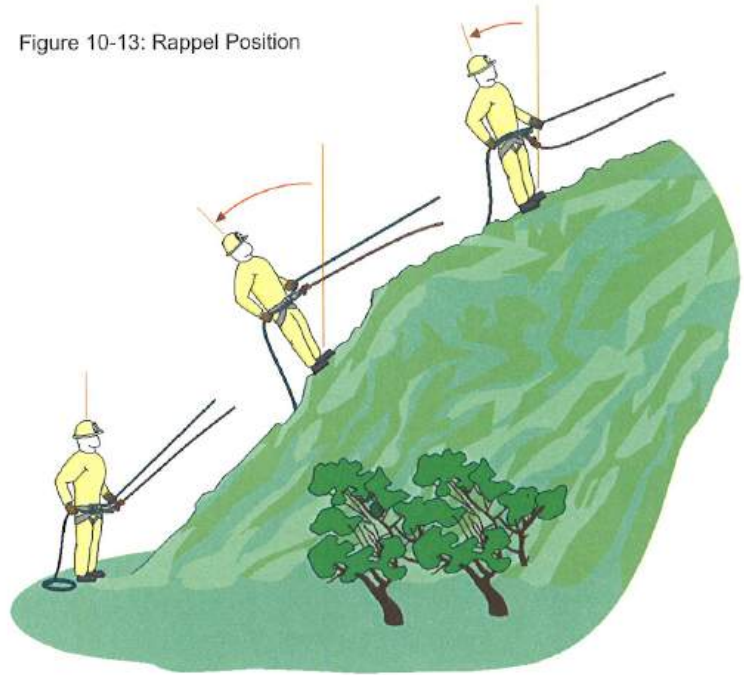

Figure 10-14: Hand Placement for a Figure Eight Descender

Brake Bar Rack

- ☐ Brake hand.
 - Grasps the rope where it comes out of the bottom of the rack.
 - Wraps it around either the 4th or 5th bar.
 - Depending on the weight of the rescuer and the angle of the slope.
 - It is always better to begin a rappel with more bars and remove them if necessary rather than not enough.
 - The brake hand is kept in the twelve o'clock position above the rack.

- Control hand.
 - Positioned underneath the rack cradling the bars.
 - This is considered to be the full brake position.
 - Friction is varied by moving the braking hand from the twelve o'clock to the five o'clock position and spreading out the bars on the rack with the control hand while stepping backwards.

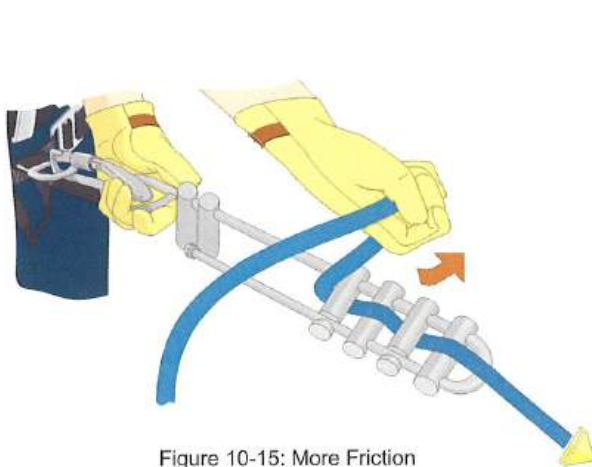

Figure 10-15: More Friction

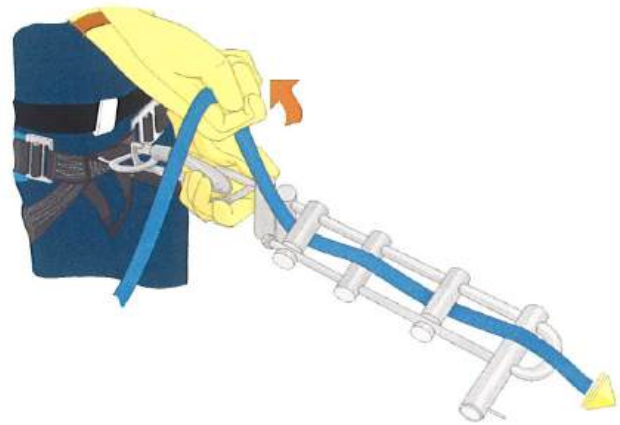

Figure 10-16: Minimum Friction

- The friction can be varied by adding or removing bars until the desired speed is achieved.
- Once the desired speed has been achieved, the control hand may be positioned either in front of the descender or just below it to help control the body's posture.

Departure

Once in the rappel position, the rescuer needs to communicate with the belayer to ensure readiness. Once on belay, the rescuer begins walking backwards to the edge. The rescuer maintains the rappel or full brake position with his or her hands. The rescuer also maintains tension on the fixed/rappel line when walking backwards. Another rescuer can assist the rappeller's transition over the edge by pulling on the line between the rappeller and the anchor to remove any slack and provide tension. This maneuver is known as a "vector pull." When the rappeller is ready to depart over the edge, the rescuer conducting the vector pull eases the rope forward until all the tension in the line has been released. The rappeller is now ready to adjust the friction and begin rappelling.

Lock-off

During a rappel, it may be necessary for the rescuer to stop the descent to perform work, package a victim, or to rest. It is necessary to lock-off the descender, whether it is a figure eight descender or a brake bar rack, until the rescuer is ready to continue the descent. Locking-off enables the rescuer to hang suspended on the main line and have the hands free to perform a function with a degree of safety. When the rescuer is ready to descend, he or she simply reverses the lock-off procedure and continues the descent.

Figure Eight Descender with Long Ears

Lock-off with Two Half Hitches

1. Allow the brake hand to move from the back of the hip to the front and hold tight when the desired lock-off point has been reached.

Figure 10-17: Grasp the Connection Point



2. Grasp the connection point where the descender meets the carabiner with the control hand and rotate the descender towards the brake hand.

Figure 10-18: Pull the Running End of the Rope

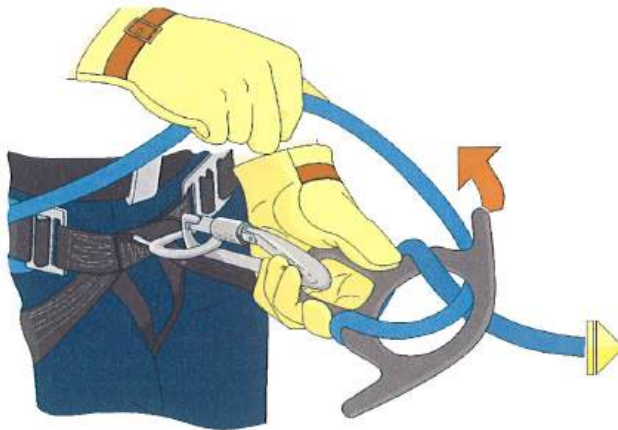

3. Pull the running end of the rope up and across the back of the descender between the standing part and the descender with the brake hand until it pops between the large hole in the descender and the main line.

Figure 10-19: Wrap the Running End

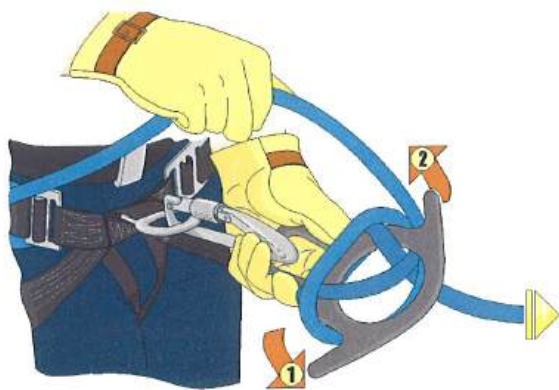

4. Wrap the running end for a second time around the front of the descender below both ears and repeat the step above until it pops between the large hole in the descender and the main line.

Figure 10-20: Continue Wrapping



5. Continue wrapping the running end across the front of the descender, under the right ear to form a long bight across the standing part of the line.

6. Use the long bight to form two half hitches on the standing part of the line. (Figures 10-21 through 10-24)

Figure 10-21



Figure 10-22

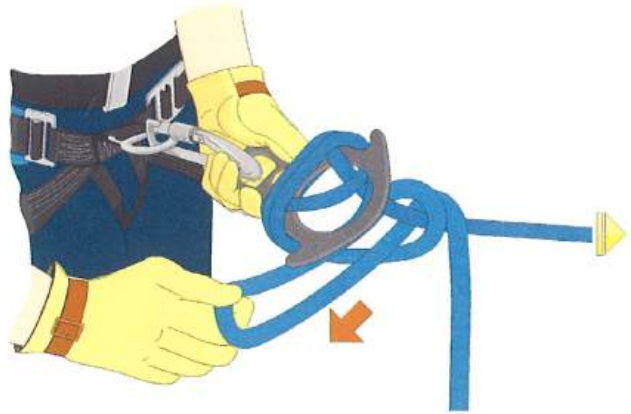

Figure 10-23



Figure 10-24



Lock-off with a Girth Hitch

1. Allow the brake hand to move from the back of the hip to the front and hold tight when the desired lock-off point has been reached.

Figure 10-25: Grasp the Connection Point

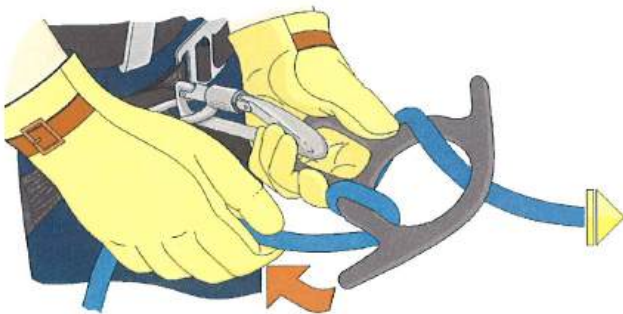

2. Grasp the connection point where the descender meets the carabiner with the control hand and rotate the descender towards the brake hand.

Figure 10-26: Pull the Running End of the Rope

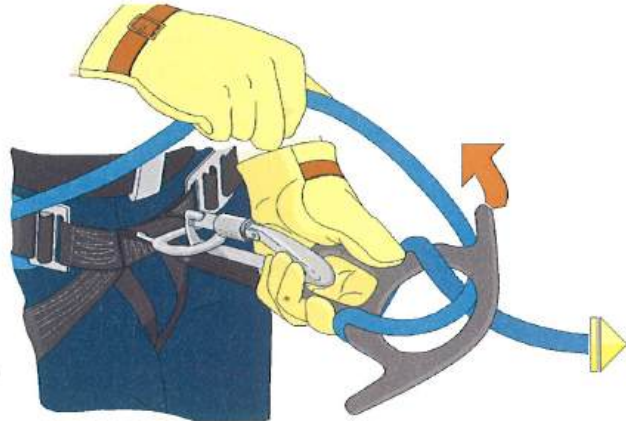

3. Pull the running end of the rope up and across the back of the descender between the standing part of the rope and the descender with the brake hand until it pops between the large hole in the descender and the main line.

Figure 10-27: Continue Wrapping

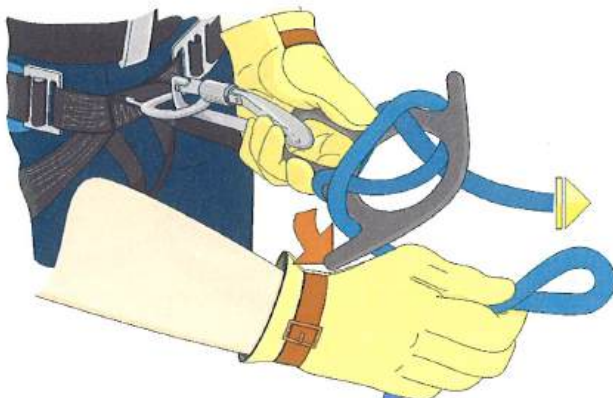

4. Continue wrapping the running end around the front of the descender below both ears and form a short bight along the standing end of the line.

Figure 10-28: Pass the Short Bight



5. Pass the short bight through the back of the descender toward the rappeller.

Figure 10-29: Pass the Bight over the Rope

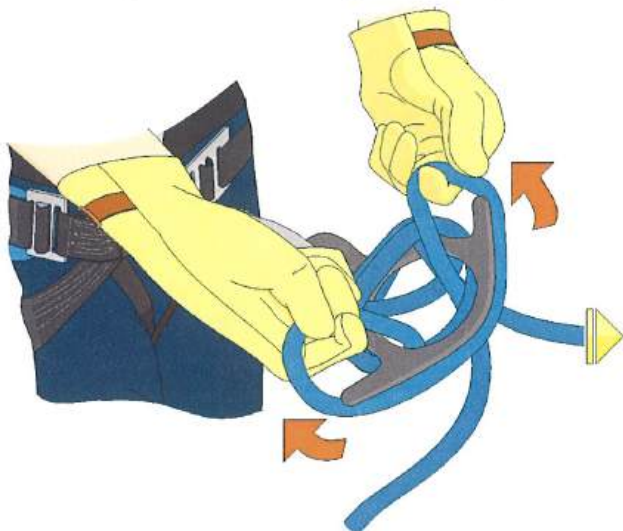

6. Pass the bight over the top of the descender forming a girth hitch around the descender.

Figure 10-30: Pull the Running End to Tighten

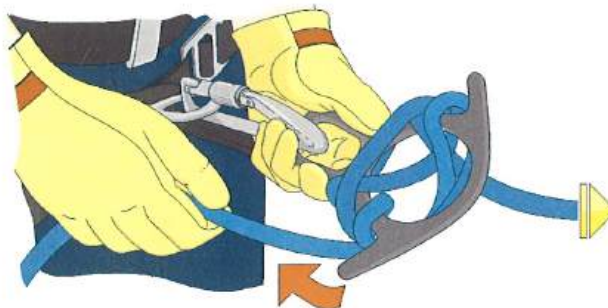

7. Pull the running end to tighten the girth hitch.

Figure Eight Descender with Short Ears

1. Allow the brake hand to move from the back of the hip to the front and hold tight when the desired lock-off point has been reached.

Figure 10-31: Grasp the Connection Point



2. Grasp the connection point where the descender meets the carabiner with the control hand and rotate the descender towards the brake hand.

Figure 10-32: Pull the Running End of the Rope

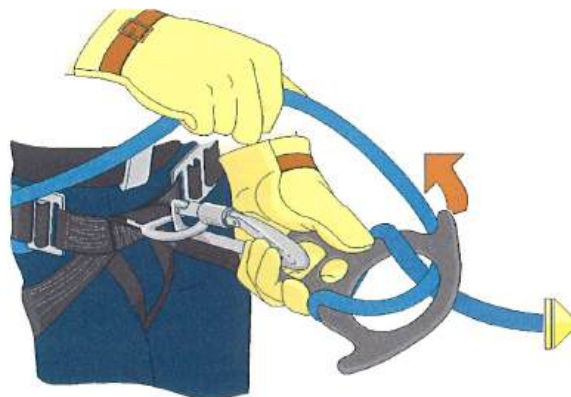

3. Pull the running end of the rope up and across the back of the descender between the standing part of the rope and the descender with the brake hand until it pops between the large hole in the descender and the main line.

Figure 10-33: Wrap the Running End

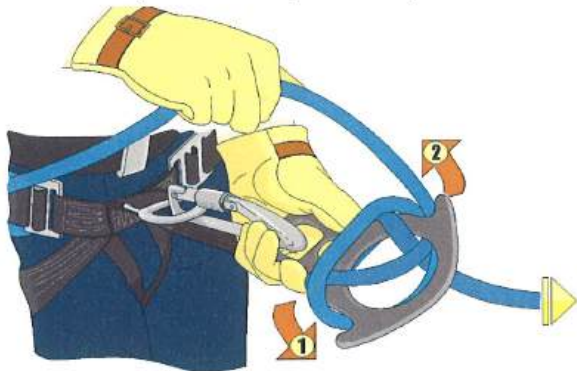

4. Create a second wrap around the descender by repeating Step 3. Pull the line firmly to set both wraps.

Figure 10-34: Pull the Line to the Right



5. Pull the line to the right, across the neck of the DCD, and through the carabiner from right to left to form an 8"-10" bight.

Figure 10-35: Twist the Bight Clockwise

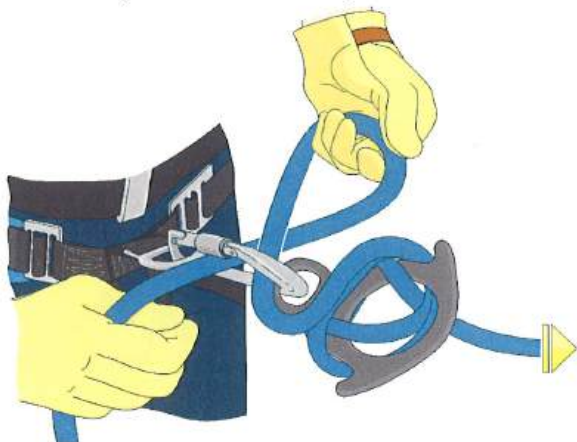

6. Twist the bight as shown to form a loop.

Figure 10-36: Pass the Loop over the Top

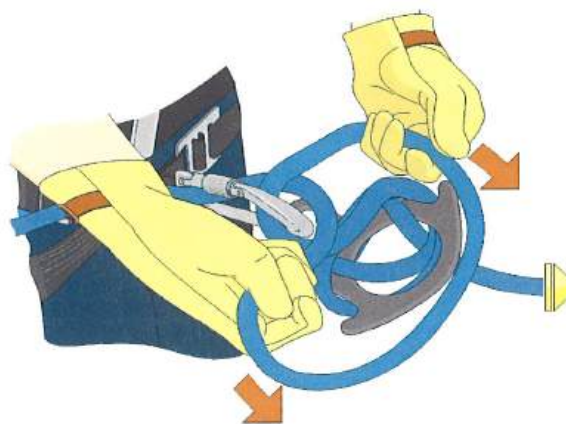

7. Pass the loop over the top of the descender.

Figure 10-37: Pull the Running End to Tighten

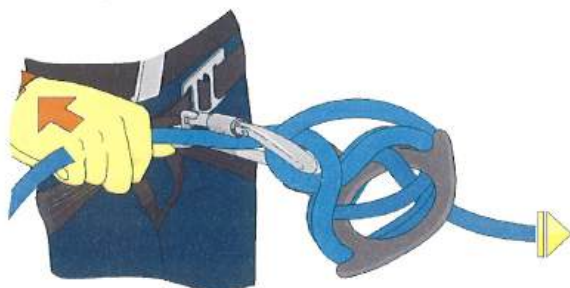

8. Pull the running end to tighten the loop.

Brake Bar Rack with a Tie-off Bar

Figure 10-38: Position Hands

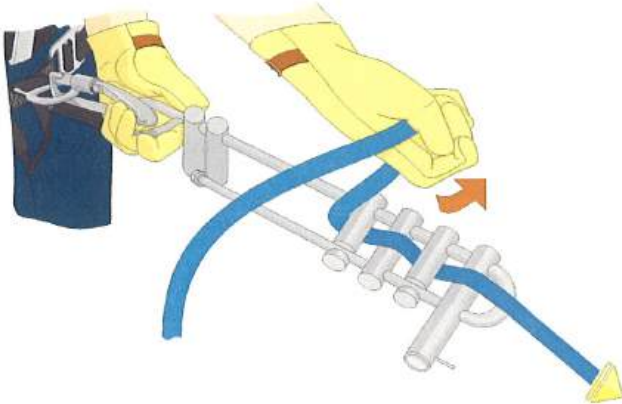

1. Position hands in the full brake position.

Figure 10-39: Wrap the Running End

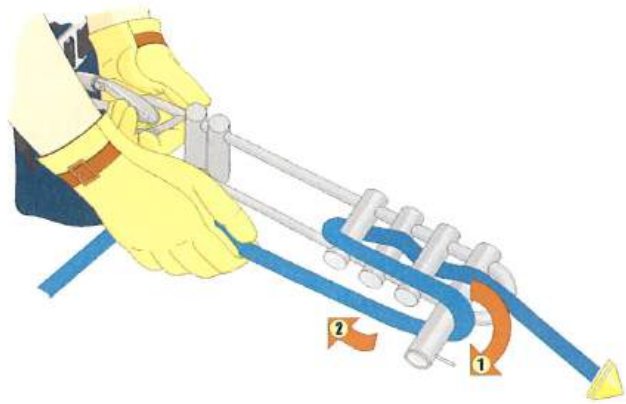

2. Wrap the running end around the tie-off bar with the brake hand.

Figure 10-40: Form a Half Hitch

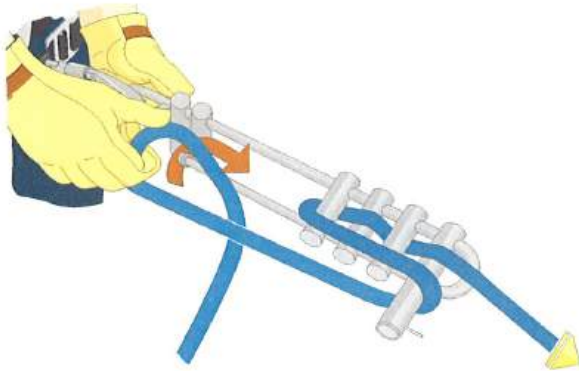

3. Form a half hitch in the running end near the opening of the rack.

Figure 10-41: Place over the Open End

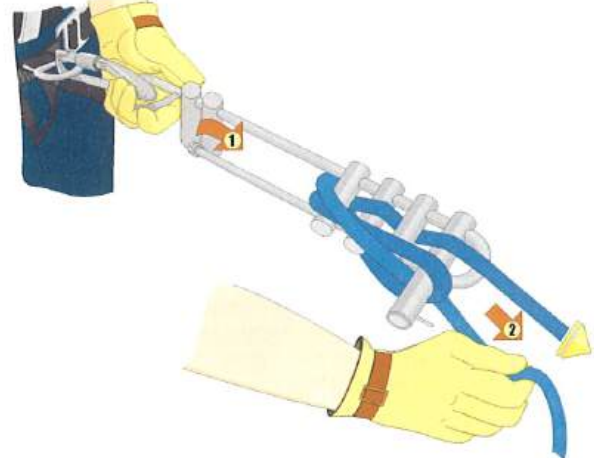

4. Place the half hitch over the open end of the brake bar rack and pull on the running end to tighten the half hitch.

Figure 10-42: Wrap the Running End

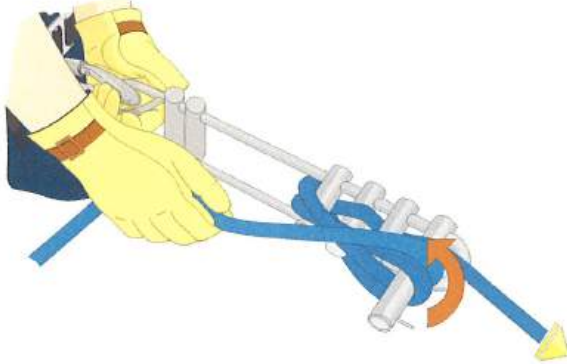

5. Wrap the running end around the tie-off bar a second time, but in the opposite direction.

Figure 10-43: Form another Half Hitch

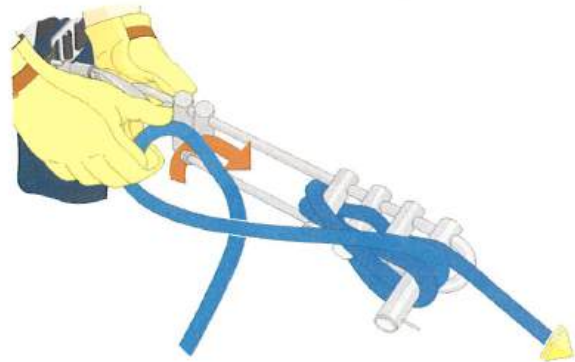

6. Form another half hitch in the running end and place it over the open end of the rack.

Figure 10-44: Pull the Running End to Tighten

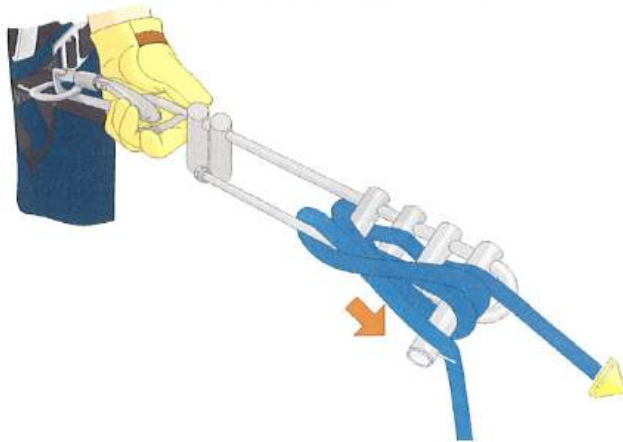

7. Pull the running end to tighten second half hitch and place over the tie-off bar.

Brake Bar Rack without a Tie-off Bar

Figure 10-45: Position Hands

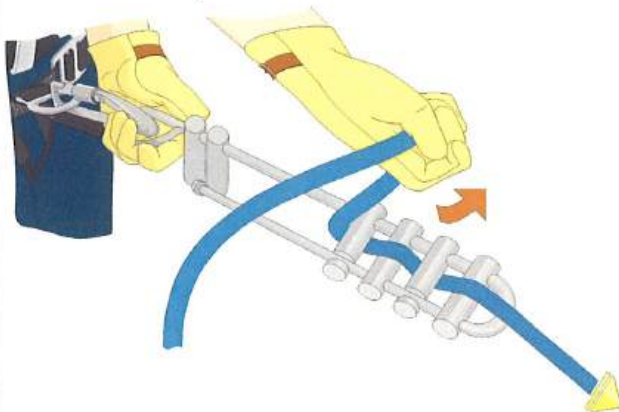

1. Position hands in the full brake position and rotate the rack towards the left.

Figure 10-46: Pull the Running End of the Rope

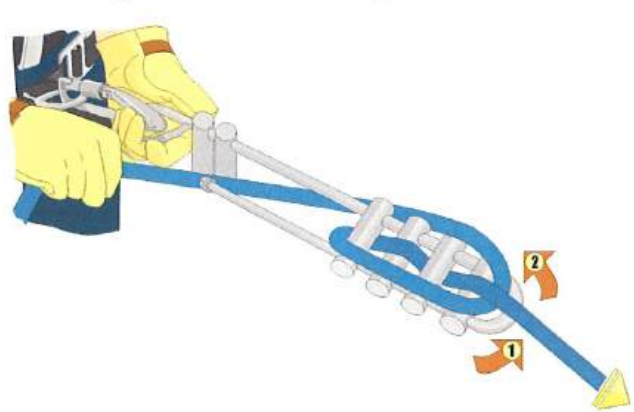

2. Use the brake hand to pull the running end of the rope across the top of the rack between the standing part of the line and the rack, continue wrapping the running end around the rack from top to bottom, come through the opening of the rack, and pull tight ending with the line above the first bar.

Figure 10-47: Make a Second Wrap

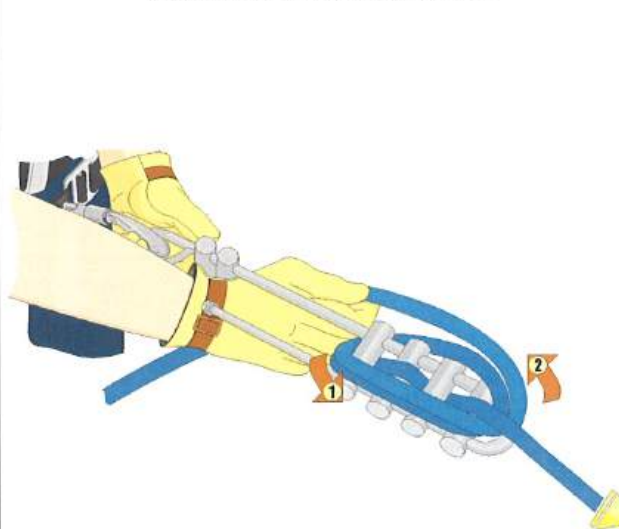

3. Make a second wrap by repeating Step 2.

Figure 10-48: Form a Bight

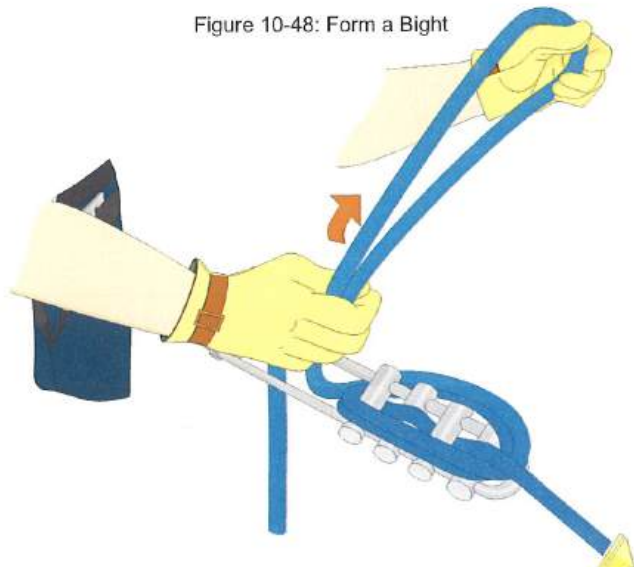

4. Form a bight in the running end.

5. Tie an overhand knot around the body of the rack. (Figures 10-49 and 10-50)

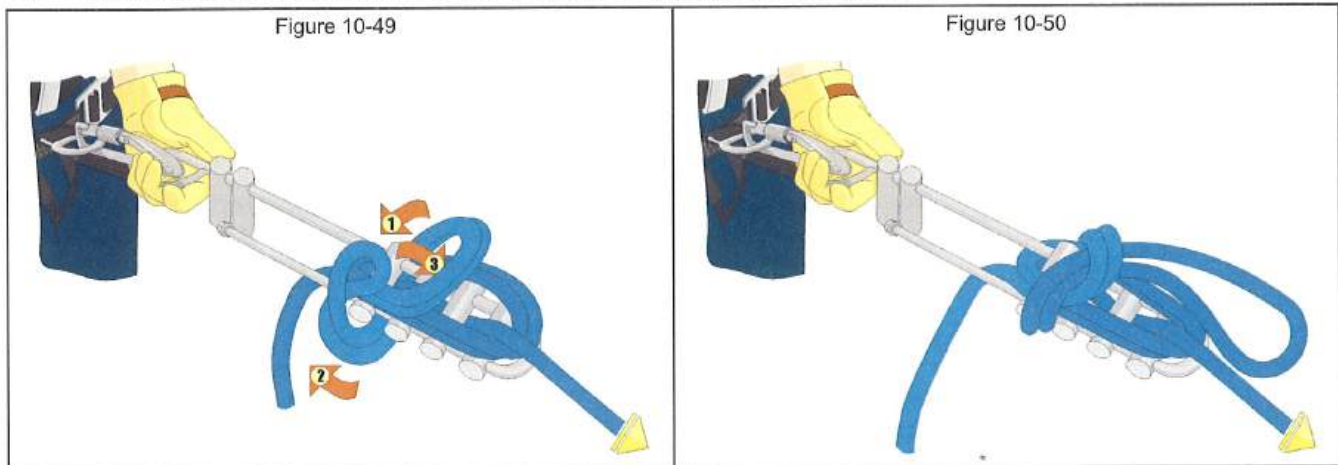

Ascending

Ascending is a very strenuous activity that is seldom used. On the occasions when it is required, it must be accomplished under controlled conditions or the outcome could be catastrophic. In most situations, it is better to bring rescuers up using a raising system from the top. In some instances, a rescuer needs to climb back to the point of origin after a rappel or for a self-rescue in the event of becoming jammed because of clothing or equipment caught in the rappel device during a rappel.

Equipment

One key to successful ascending, whether it is to return to the point of origin or for self-rescue, is to be equipped with the necessary equipment before the descent. The minimum equipment necessary for low angle ascending includes one (1) long prusik loop and one (1) extra carabiner.

Ascending for Positioning or Returning to Departure Point

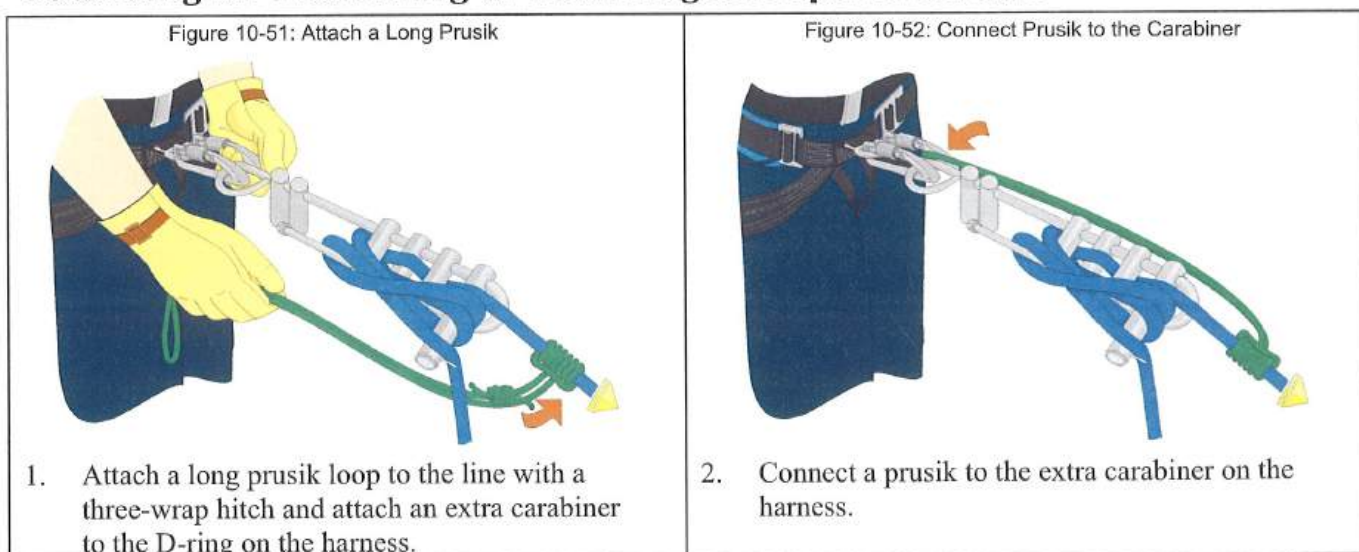

Figure 10-53: Slide Prusik Hitch up the Line



3. Slide the prusik hitch up the line with one hand while pulling the running end taut with the other hand. (Figure 10-53)
4. Simultaneously step forward.
5. Remember to keep the lower body perpendicular to the slope.
6. Disconnect the main line from the brake bar rack.
7. Repeat Steps 3-5 until the desired location has been reached.

How to Escape from a Jammed DCD

Topside Recovery Option

- Rescuer
 - Attaches a long prusik loop to the line in front of the DCD and connects it to the extra carabiner on the harness.
 - Slides prusik forward and leans back in order to tension/load the prusik.
- Topside Crew
 - Changes the fixed line over to a raising system and raises the rescuer to the top or a safe location to unjam the DCD.

Self-rescue Option

1. Attach a prusik loop to the line in front of the DCD and connect it to the harness with a second carabiner.
2. Ensure the Belayer is ready for raising belay.
3. Slide prusik hitch up the line with one hand while pulling the line taut with the other hand located between the DCD and the prusik hitch.
4. Simultaneously step forward.
5. Remember to keep lower body perpendicular to the slope.
6. Repeat these steps until there is enough slack to unjam the DCD.
7. Unjam the DCD.
8. Take slack out of the rappel line.
9. Lock the DCD.
10. Lean forward.
11. Remove the prusik.
12. Unlock the DCD.
13. Continue the rappel.

Chapter 11: Lower/Raise (Mechanical Advantage) Systems

Scope: This chapter serves as an introduction to lower/raise (mechanical advantage) systems.

Terminal Learning Objective (TLO): At the end of this chapter, the student will be aware the considerations when selecting the type of mechanical advantage system (MA) to be used in a raising operation.

Enabling Learning Objectives (ELO):

1. Describe rope rescue lowering and raising systems
2. Demonstrate how to convert a lowering system to a raising system with a 3:1 inline - rpm
3. Demonstrate how to operate a lowering system
4. Demonstrate how to convert a lowering system to a raising system with a 5:1 inline – rpm and a 3:1 or 5:1 inline with directional pulley
5. Demonstrate how to construct a 3:1 and 5:1 mechanical advantage system
6. Demonstrate how to construct a 3:1 and 5:1 pig rig
7. Demonstrate how to convert a lowering system to a raising system with a 3:1 and 5:1 pig rig

Rescue operations in low angle rope rescue, in terms of victim extrication, are primarily a lower/raise function. The tools and staffing positions to complete the lowering operations can be completed off the main line component of an RPM system.

This may not be the case with raising operations. Equipment may be required from the mechanical advantage component and an additional line may be required as well.

Therefore, the rescuer has a few options to consider when selecting the type of mechanical advantage system (MA) to be used in a raising operation. This chapter will show the following considerations for MA systems:

- The inline MA system.
- The inline MA system with a change of direction.
- The piggyback system.
- Straight pull.
- Apparatus positioning.

Key Points Regarding Lower/Raise Operations

- Basic lowering operations and inline MAs can be accomplished off the main line component and be supervised by the Rope Group Supervisor (RGS). A more detailed explanation of job titles and functions is in Chapter 13.
- MA systems with a directional change require additional equipment and staffing. This includes both in-line and piggyback systems.
- A Haul Team Leader will direct the construction of the MA system, command and control the haul team, and report to the RGS. This is a key management position and requires a person with strong leadership skills and a high technical knowledge base of rope rescue operations.
- Apparatus positioning is also very important. Proper positioning of the apparatus will ensure a safe and adequate working area for personnel and maximize the effectiveness of the MA system used.
- As the name denotes, this is the primary line in any rope system. The main line will be loaded during rappel and lowering and/or raising operations. The main line may also have the additional duty of a haul line in some mechanical advantage systems.

Lowering Line Systems

- All or part may be prerigged and bagged.

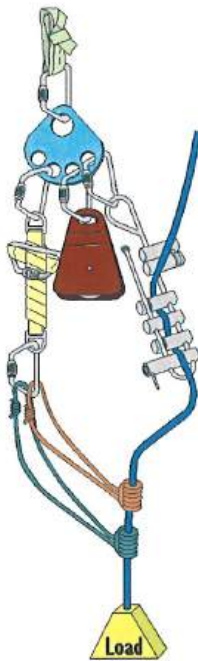

Figure 11-1: With Brake Bar Rack

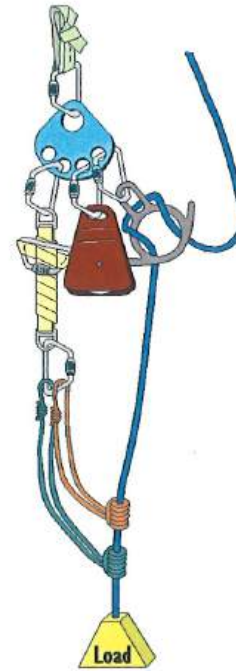

Figure 11-2: With Eight Plate

System Staffing

- Lowering line tender(s) **required**.
 - Tends descent control device (figure eight plate or brake bar rack).
- Lowering line brake **optional**.
 - If used, a brake tender is **required** to tend the tandem prusiks.

System Operation

- Brake bar rack – one- or two-person load.
 - One tender - adjusts bars as required.
- Figure eight plate – one-person load.
 - One tender – adjusts attachment as needed.
- Figure eight plate – two-person load.
 - Two tenders – adjust attachment as needed.
- Tandem prusik brake.
 - May be removed (staffing or operational considerations).
 - Staffed by main line brake tender when used.

Raising (MA) Systems

These systems are typically utilized after lowering operations are complete. They are either constructed at the scene as part of the main line with component pieces (inline system) or are prepackaged in a separate rope bag and attached to the main line (piggyback system). This chapter deals with the following variations of the haul/MA systems:

- ❶ 3:1 and 5:1 inline MA systems.
- ❷ 3:1 and 5:1 MA systems with a directional change pulley.
- ❸ 3:1 and 5:1 piggyback systems.
- ❹ Straight pull system.

System Staffing¹

- Main Line Brake Tender.
- Haul Team.

Key Points Regarding Raising Operations²

Prusik Brake(s)

The prusik brake(s) shown in this chapter are not ratchet cams; they are not configured to self tend. The distance is too great between the pulley and the prusik. This distance creates an excessive amount of slack in the main line if released or set. The brake(s) *must*, therefore, be tended.

Haul Team

The Haul Team will typically grasp the line and walk in a controlled manner to apply force to the system. In situations of limited hauling space, the team will haul using the hand-over-hand method.

Lower to Raise Conversion: 3:1 Inline – RPM

- 1) Tie off the DCD as shown in Chapter 10.
 - If prusiks were not attached to the main line during lowering operations.
 - Not needed if litter team/rescuers are on a safe level platform.
 - Not needed if the lowering line tender holds tension as prusiks are attached.
- 2) Attach prusik(s) to the line if not previously attached during the lowering operation.
 - One prusik is proven adequate as a brake to the main line.
 - It is not necessary to attach the second prusik to the main line, but it is acceptable to do so.

¹ Additional positions are described in Chapter 13: Scene Organization and Management.

² Additional key points are described in Chapter 13: Scene Organization and Management.

Lower to Raise Conversion: 5:1 Inline – RPM

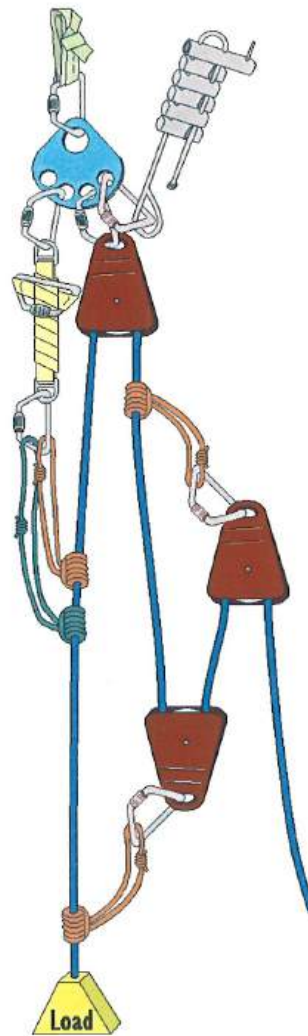

Figure 11-6

- 1) Attach haul prusik (short) to line on haul side of prusik minding pulley on RPM.
- 2) Install haul line in second mechanical advantage pulley.
- 3) Connect second mechanical advantage pulley to haul prusik with carabiner.

Lower to Raise Conversions

Once lowering operations are completed, the rescuer and victims most often must be pulled back up the incline to a safe area. This is accomplished by utilizing mechanical advantage or haul systems. In order to accomplish this, the rescuer must know how to convert a lowering system to a raising system. This initial conversion process will be the same for all mechanical advantage systems in this course.

3:1 or 5:1 Inline Mechanical Advantage System

If the distance between the main line anchor and edge is adequate, an inline mechanical advantage system will be used. Adequate distance will provide the hauling team a safe area to work inline toward the incident. This distance must also be long enough to minimize the number of resets necessary to complete raising operations. Keep in mind how much rope will be used to reach the victim(s); this will determine your maximum set back.

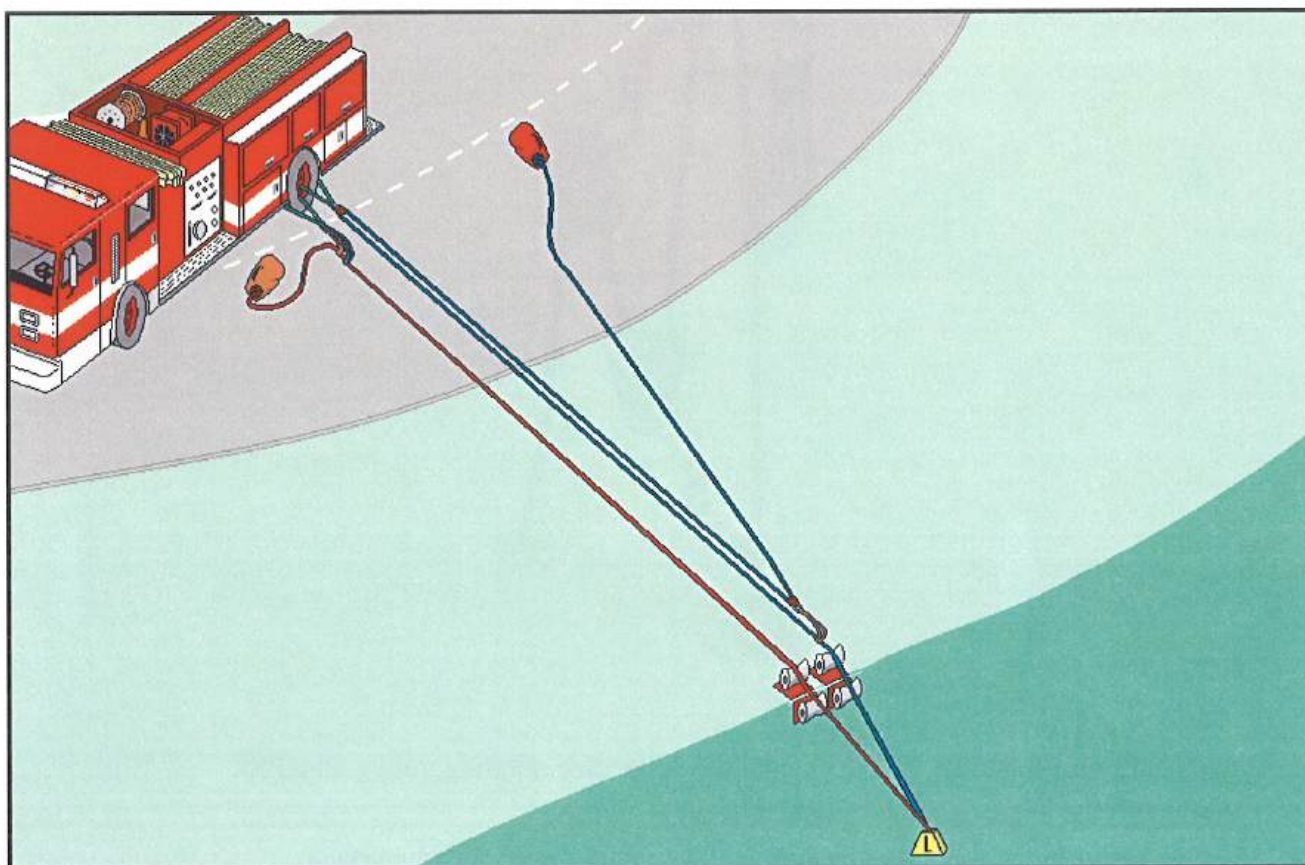

Figure 11-7: 3:1 or 5:1 Mechanical Advantage Inline System Layout

3:1 or 5:1 Inline with Directional Pulley

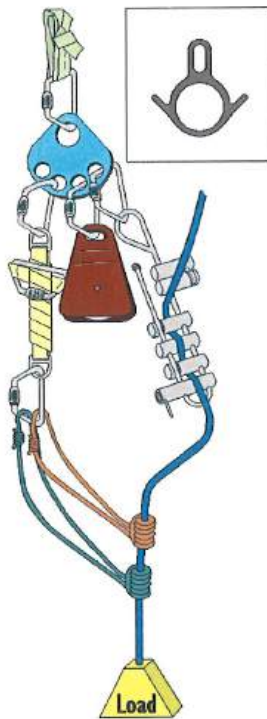

Figure 11-8: Lower with Load

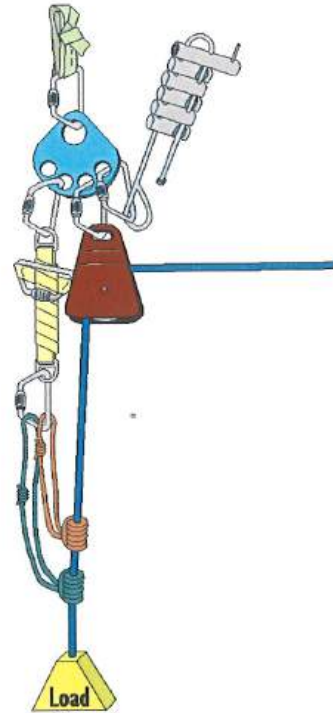
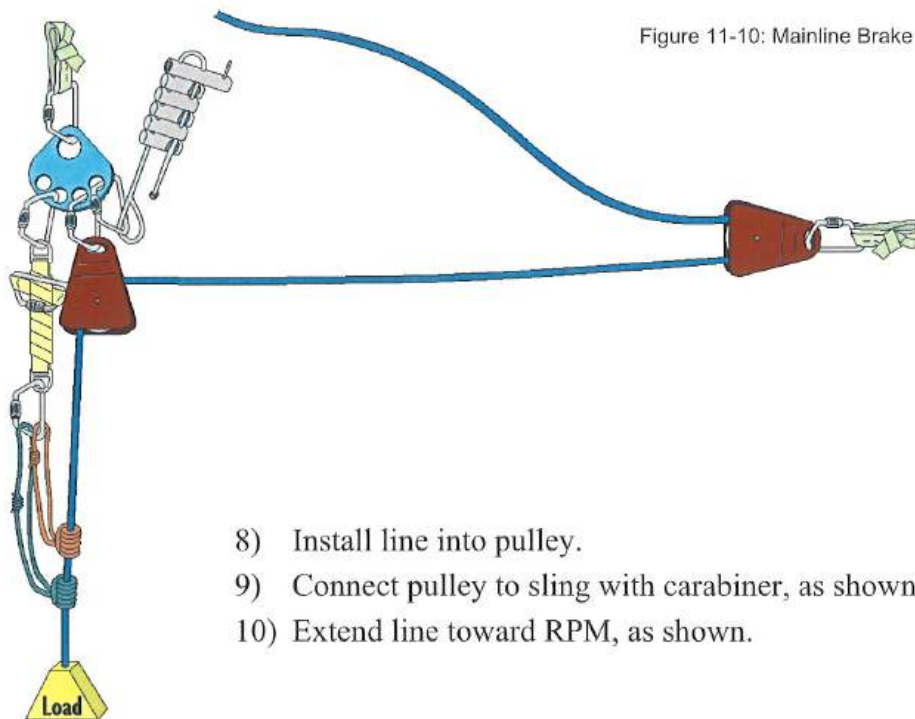
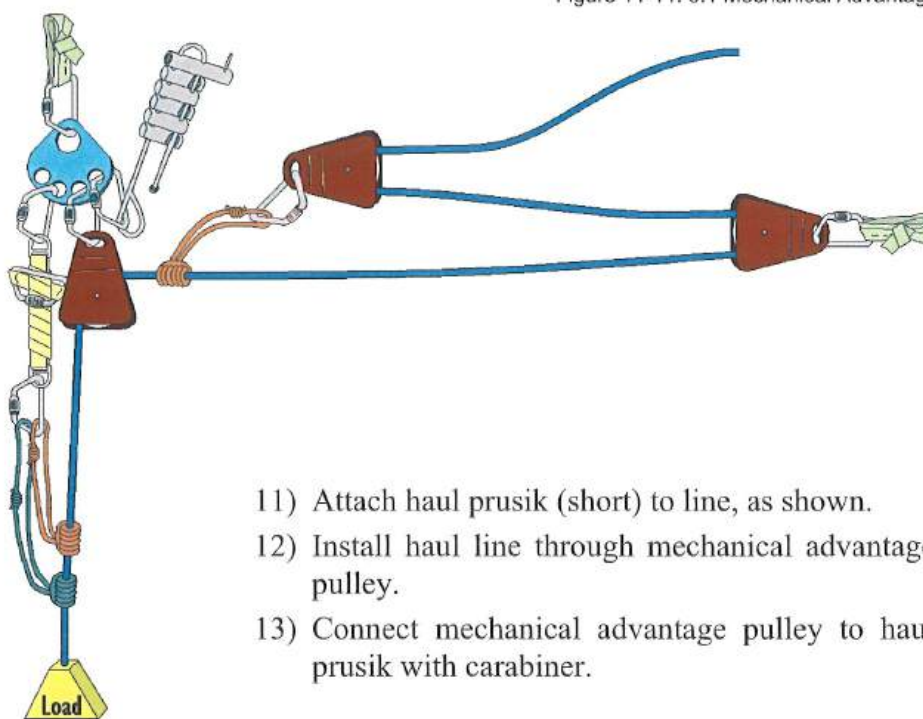

Figure 11-9: Mainline Brake with Load

- 1) Tie off the DCD as shown in Chapter 10.
 - If prusiks were not attached to the main line during lowering operations.
 - Not needed if litter team/rescuers are on a safe level platform.
 - Not needed if the lowering line tender holds tension as prusiks are attached.
- 2) Attach prusik(s) to the line if not previously attached during the lowering operation.
 - One prusik is proven adequate as a brake to the main line.
 - It is not necessary to attach the second prusik to the main line, but acceptable to do so.
- 3) Set the prusik(s) brake.
- 4) Remove the line from the DCD.
- 5) Install the line through the prusik minding pulley.
- 6) Place the line toward the secondary anchor (second apparatus).
- 7) Attach sling to secondary anchor. The secondary anchor is often a vehicle or picket system positioned along the road or trailhead at an angle to the mainline RPM as shown. Always maximize the distance between these two anchors in order to reduce the number of resets during hauling [raising] operations. In a **3:1** system, that distance will be one-half the length of the remaining rescue line. In a **5:1** operation, that distance will be one-third.



- 8) Install line into pulley.
- 9) Connect pulley to sling with carabiner, as shown.
- 10) Extend line toward RPM, as shown.



- 11) Attach haul prusik (short) to line, as shown.
- 12) Install haul line through mechanical advantage pulley.
- 13) Connect mechanical advantage pulley to haul prusik with carabiner.

Often at low angle rope rescue incidents, there is inadequate working area for an inline mechanical advantage system. In these situations, a directional change pulley is used at the main line RPM to change the direction of the main line to a secondary anchor (often a second engine). This apparatus is located a good working distance (approximately one-half the length of the unused rope in the bag for a 3:1 mechanical advantage system or one-third the length of unused rope in the bag for a 5:1 mechanical advantage system) from the main anchor and placed parallel to the roadway or trail. When an apparatus is staged in this position, it can also provide a safe working area for the haul team.

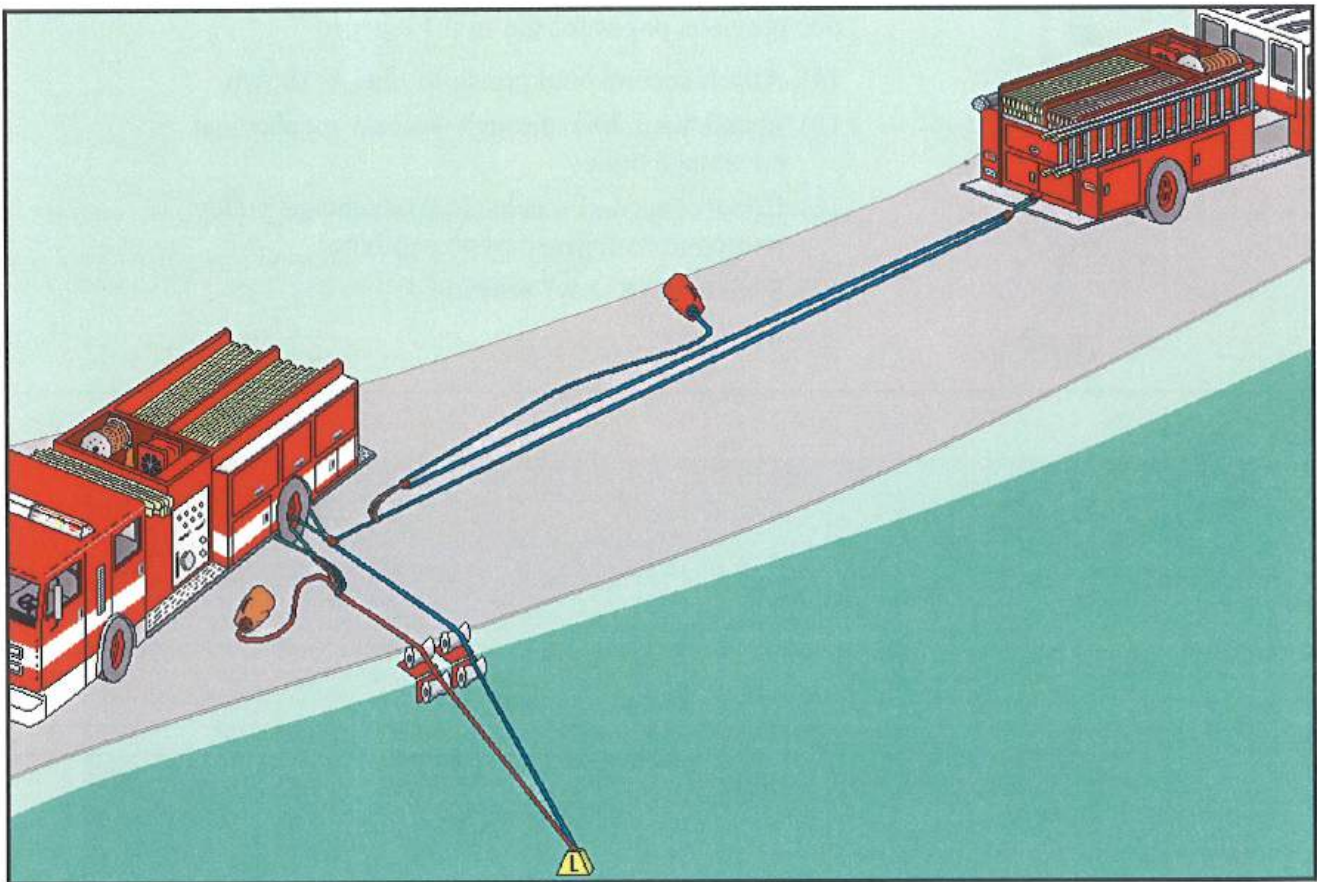

Figure 11-12: 3:1 Mechanical Advantage Directional Change System Layout

Key Points for Apparatus Placement

- The set back of the apparatus and/or anchor will be determined by your working area, type of mechanical advantage used, and the amount of line used.
 - Consider the condition of the edge. Will it support the apparatus?
 - Consider your minimum working space. Is it enough room for the litter, RPM, and their operation?
 - Consider your maximum working space. It is dependent on the rope length and available area.
- The angle that the apparatus is positioned will determine how raising operations are set up.
 - Position the apparatus with enough angle to provide clear access to the secondary anchor/apparatus.
 - The angle is determined by the location and lay out of the apparatus.

Piggyback Systems

Introduction

In long lowering operations, most of the main line can be used in the primary lower. This will not leave enough line to construct an inline mechanical advantage system. In these situations, a "piggyback" or "pig rig" mechanical advantage system is used. In this course, two options will be presented: a 3:1 and a 5:1 piggyback system. As with inline systems, the 5:1 will build off the 3:1 rigging.

Key Points

- A piggyback system adds another line to the main (lowering) line, much as a block and tackle does. This added line will provide the mechanical advantage needed for raising operations and is often referred to as the haul line, MA line, or pig line.
- The pig rig concept allows the first-in companies to fully extend the first two lines (belay/safety and main) to the incident.
 - It also allows a second-in company to construct, extend, anchor, attach, and operate the mechanical advantage system.
- Many teams carry a preassembled pig rig in a third rope bag. This can be quickly extended and attached to the main line, reducing set-up time for the raising system.

Pig Rig Construction: 5:1

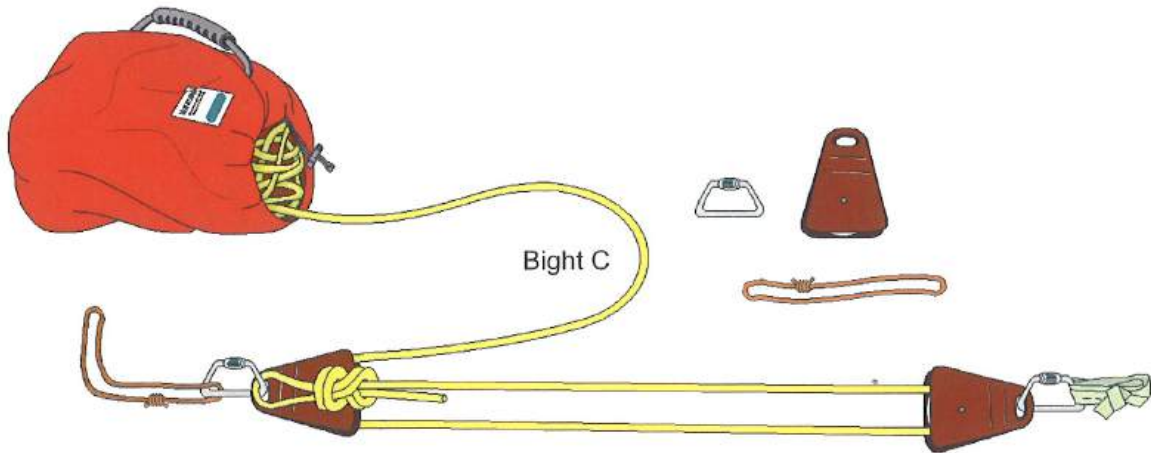

Figure 11-17: How to Construct a 5:1 Pig Rig Starting from a 3:1 Pig Rig

- 1) Place the rope on the ground to form bight "C."
- 2) Place bight "C" inside the pulley and connect a carabiner to this pulley.
- 3) Attach a short prusik to the line at the pulley on bight "B" using a three-wrap prusik hitch.
- 4) Connect the prusik loop to the bight "C" pulley with the carabiner.

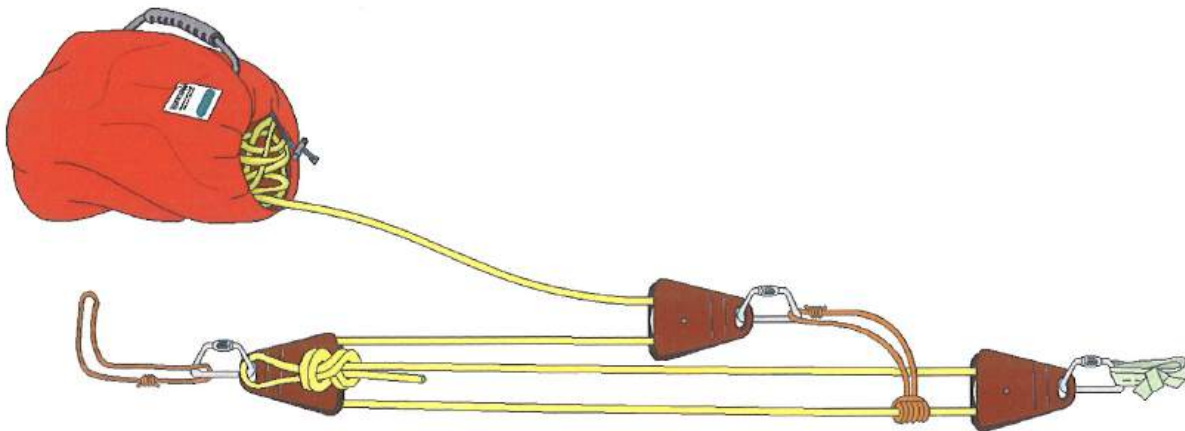

Figure 11-18: Assembled 5:1 Pig Rig

- 4) Remove the line from the DCD.
- 5) Install line through prusik minding pulley.
- 6) Place line toward secondary anchor (second apparatus).
- 7) Construct the 3:1 pig rig or lay out preassembled pig rig.

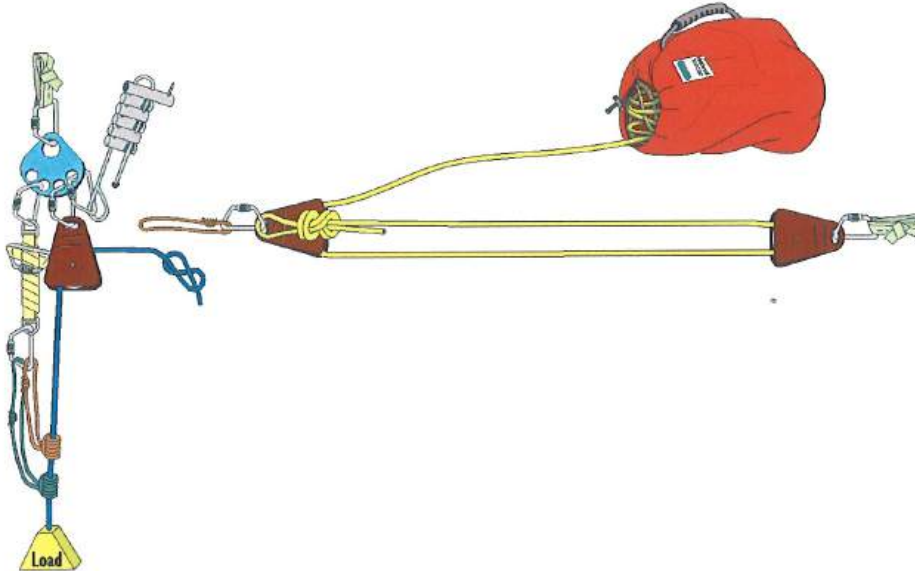

Figure 11-21: Construct 3:1 Pig Rig

- 8) Extend the 3:1 pig rig from the secondary anchor to the main line anchor.

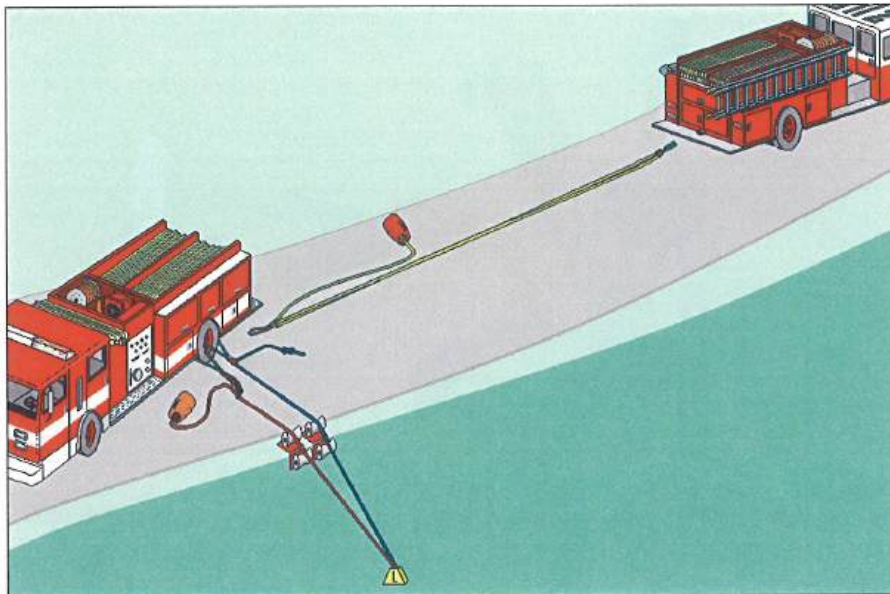

Figure 11-22: Extend 3:1 Pig Rig

11) System in "Ready" position.

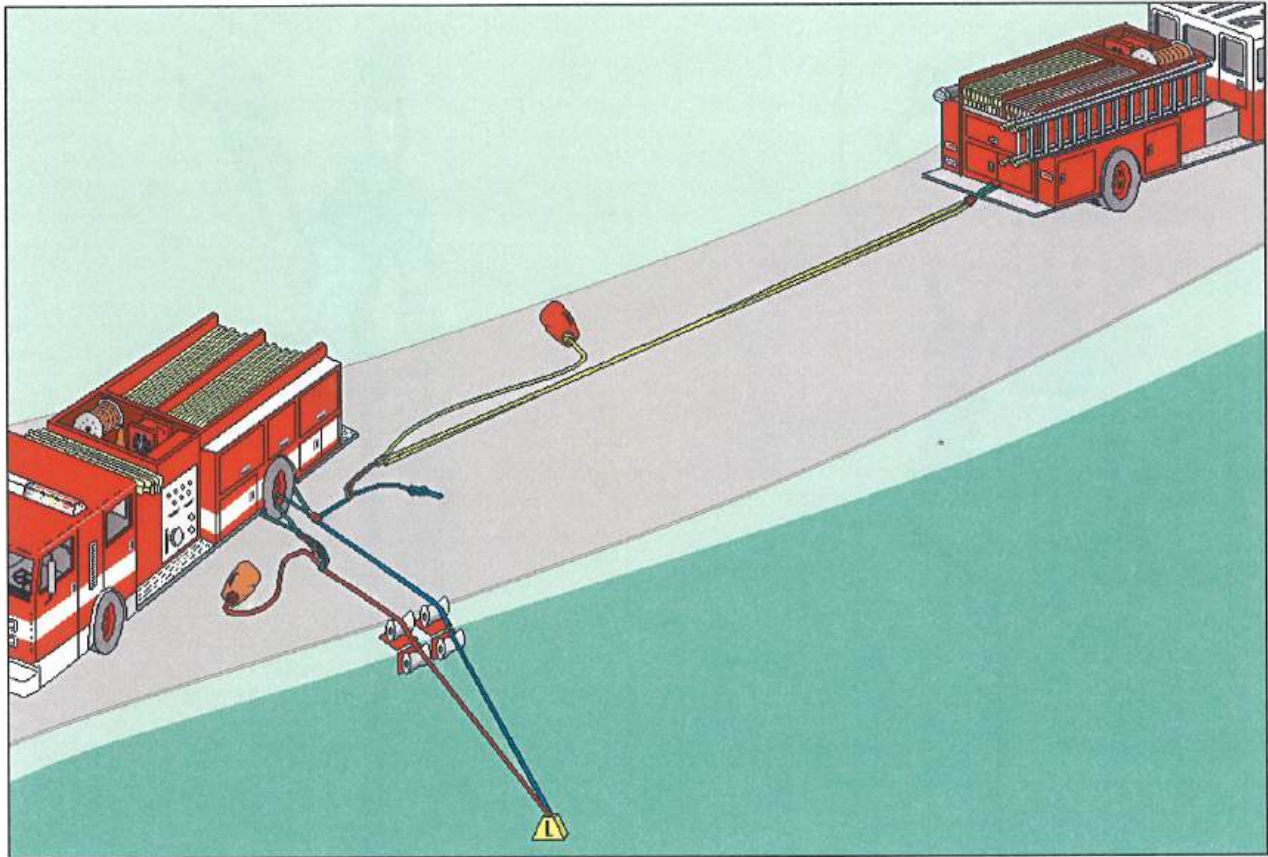

Figure 11-25: 3:1 Pig Rig with Directional Change System Layout

Key Points for Apparatus Placement

- The set back of the apparatus and/or anchor will be determined by your working area, the type of mechanical advantage used, and the amount of line used.
 - Consider the condition of the edge. Will it support the apparatus?
 - Consider your minimum working space. Is it enough room for the litter, RPM, and their operation?
 - Consider your maximum working space. It is dependent on the rope length and available area.
- The angle that the apparatus is positioned will determine how raising operations are set up.
 - Position the apparatus with enough angle to provide clear access to the secondary anchor/apparatus.
 - The angle is determined by the location and lay out of the apparatus.

- 7) Construct the 5:1 pig rig or lay out preassembled pig rig.



Figure 11-28: Construct 5:1 Pig Rig

- 8) Extend the 5:1 pig rig from the secondary anchor to the main line anchor.

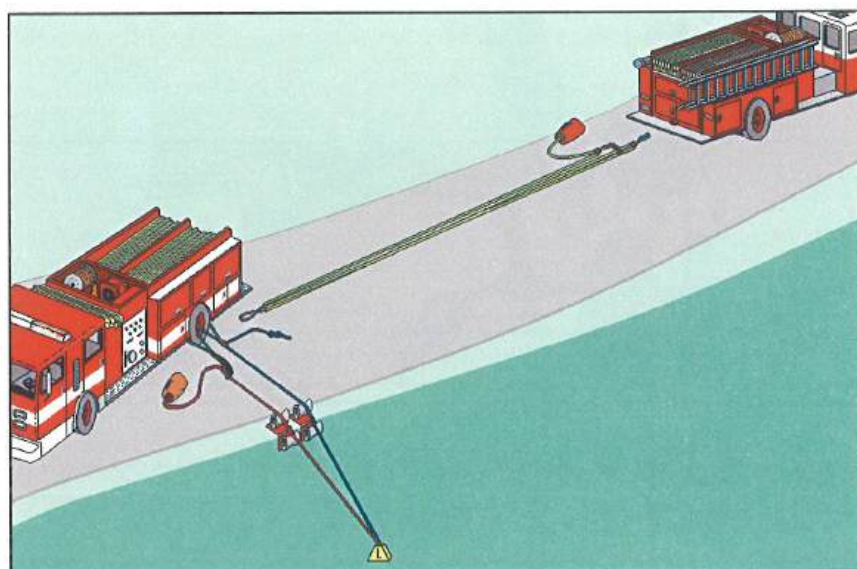

Figure 11-29: Extend 5:1 Pig Rig

11) System in "Ready" position.

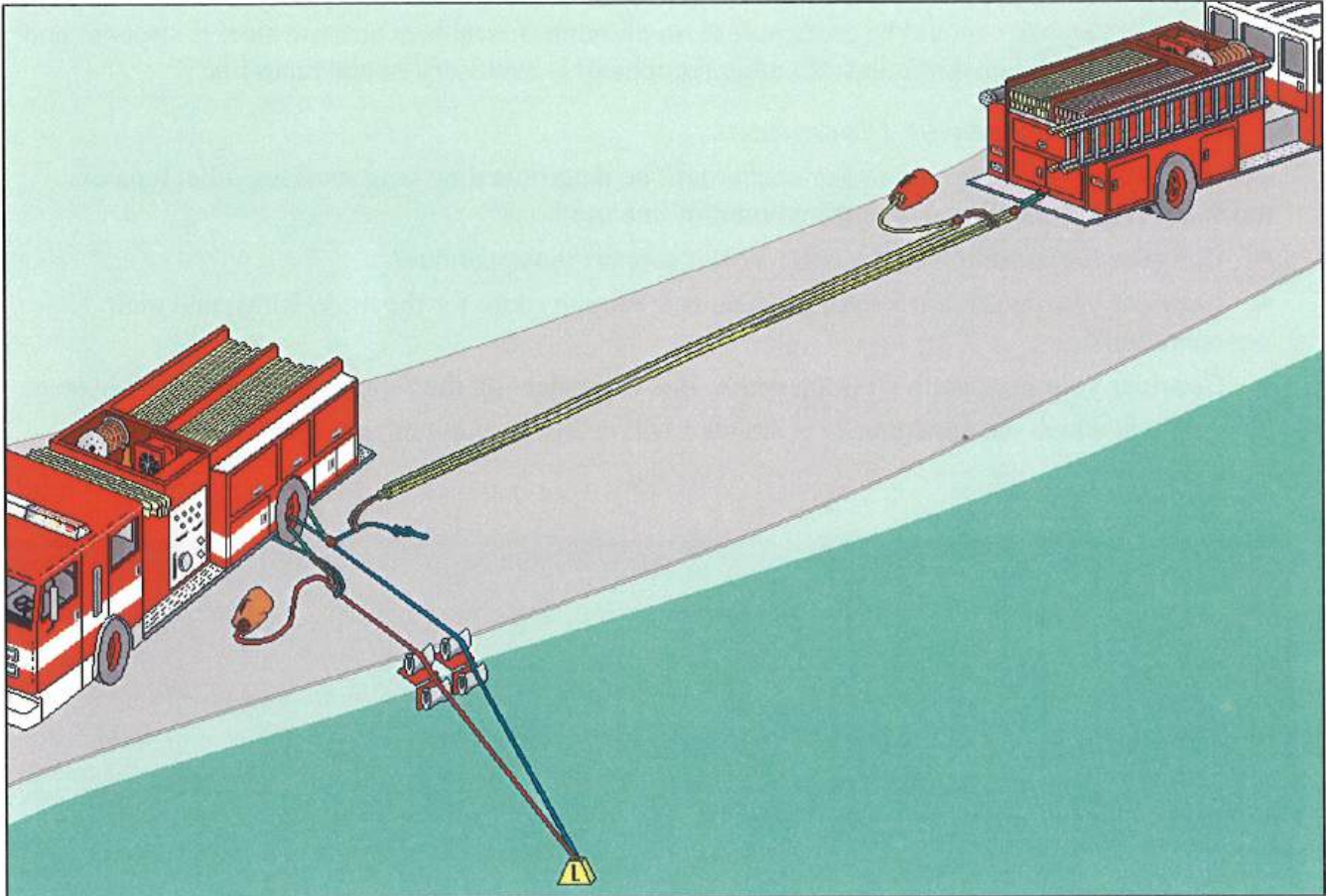

Figure 11-32: 5:1 Pig Rig with Directional Change System Layout

Straight Pull

Occasionally, the situation may arise where responders have adequate staffing but limited equipment with which to construct a mechanical advantage system. In these cases, an option to consider is the straight pull.

The formula to calculate a straight pull or 1:1 mechanical advantage system is that each rescuer hauling on the line can pull approximately 100 pounds of load.

Environmental conditions such as terrain and weather may affect the rescuers grip and footing. Thus, a 400-pound load to be lifted would require a minimum of 4 rescuers on the haul line. In a low angle haul situation, the amount of load may be increased or reduced by the following factors: 1) the angle of slope and 2) the amount weight being transferred from the litter tenders to the ground.

In low angle applications of the straight pull, two lines are used. The safety line uses a brake system, such as tandem prusiks, connected to a suitable anchor. The main line typically runs through a change

Chapter 12: Load-releasing Methods

Scope: This chapter serves as an introduction to loading-releasing methods.

Terminal Learning Objective (TLO): At the end of this chapter, the student will be aware of the most common difficulties encountered involving prusik brakes and provide functional solutions for these situations.

Enabling Learning Objectives (ELO):

1. Describe load-releasing methods
2. Demonstrate how to construct and operate a load-releasing device during rappelling, lowering, or raising operations

Most low angle rope rescue operations involving properly trained personnel will be smooth and trouble free. Teams may encounter operational challenges involving the prusik hitches employed as brakes through the rope rescue system. This chapter will outline the most common difficulties encountered involving prusik brakes and provide functional solutions for these situations. Often the simplest solution will be to have the rescuers lean or move uphill, slacking the problem line. However, this technique is not always practical and the specific approach should be chosen based on the needs of the scenario. Teams are likely to encounter challenges involving prusik brakes during the following operations.

- Rappelling operations.
 - Tandem prusik brake set on the belay/safety line.
- Lowering operations.
 - Tandem prusik brake set on the belay/safety line.
- Raising operations.
 - Load jammed against an obstacle, prusik brake set on the belay/safety line and main line brake.

Rappelling or Lowering Operations

During rappelling or lowering operations, the tandem prusik brake may be unintentionally set on the belay/safety line. If this occurs, there are two recommended techniques that can be employed in order to release the brake. The main line can be secured at the rescuer's DCD (rappelling) or main line anchor (lowering) and the line can be "vectored" or a "Z-rig" can be constructed in the belay/safety line in order to release the set brake.

Load Releasing Using the Vector Method

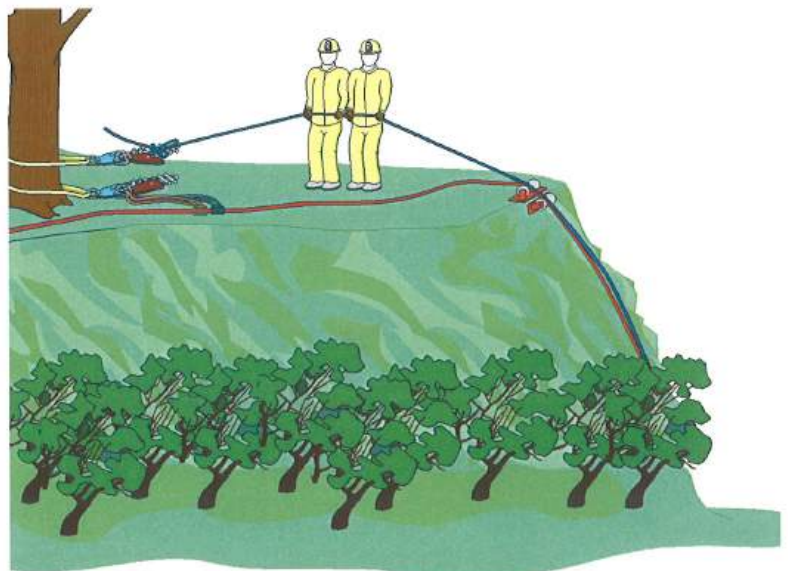

Figure 12-1: Vector

- Form a three-wrap prusik on the belay/safety line on the load side of the tandem prusik brake. (Figure 12-4)

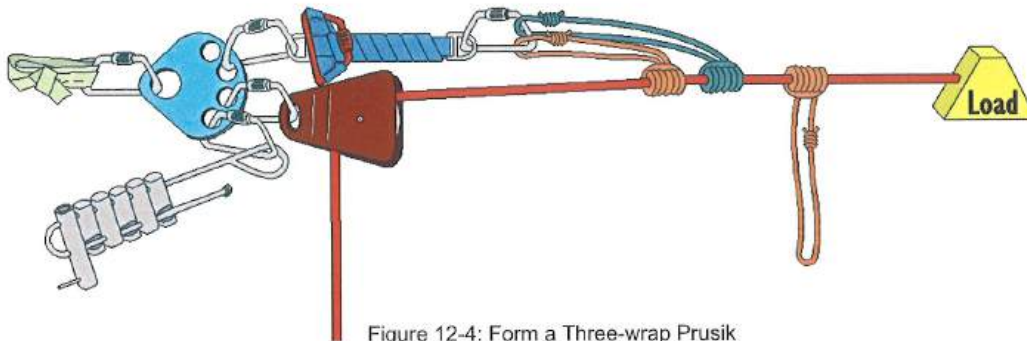

Figure 12-4: Form a Three-wrap Prusik

- Attach a carabiner through the prusik hitch and clip the belay/safety line into the carabiner. (Figure 12-5)

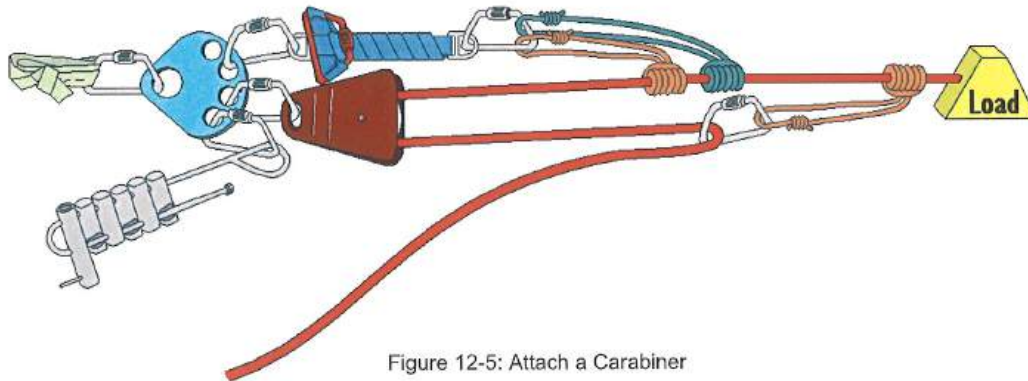

Figure 12-5: Attach a Carabiner

- Rescue Group Supervisor assembles the necessary personnel to tension the belay/safety line.
- Under the direction of the Rescue Group Supervisor, tension the belay/safety line to provide adequate slack in order to clear the jammed prusik brake.

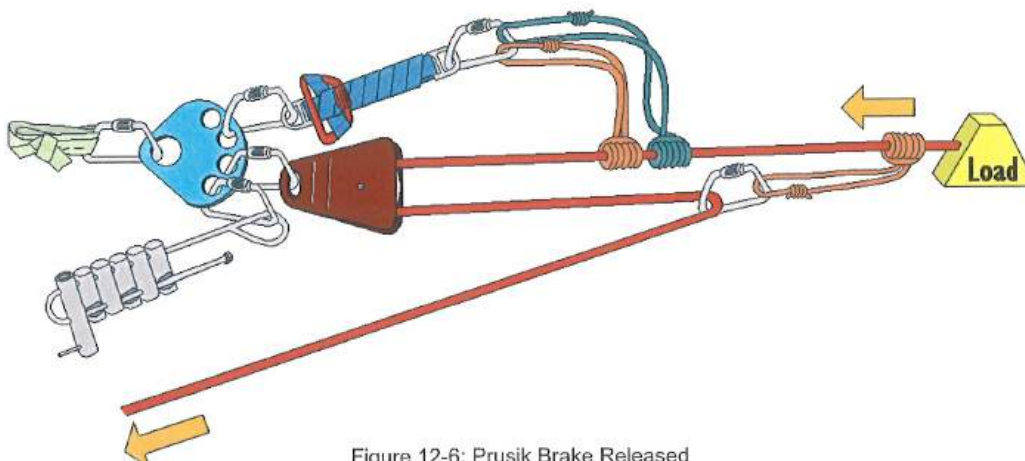
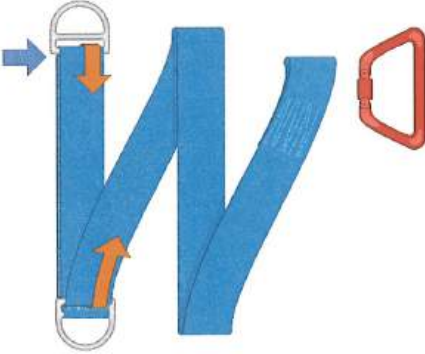
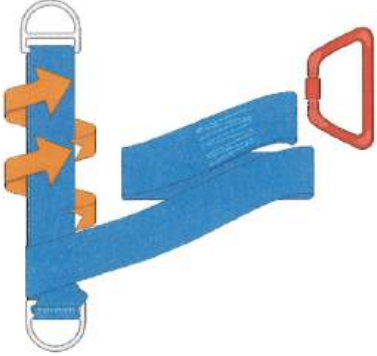
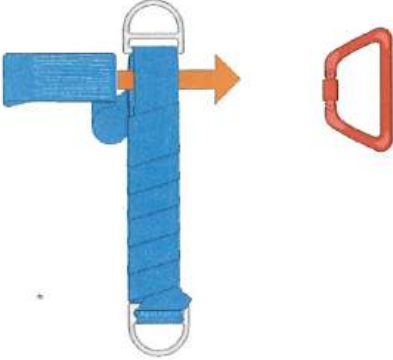
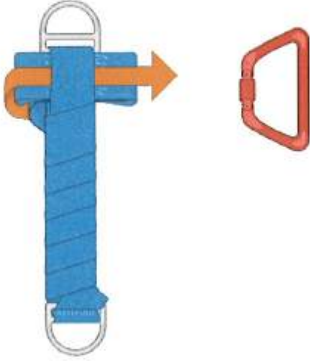
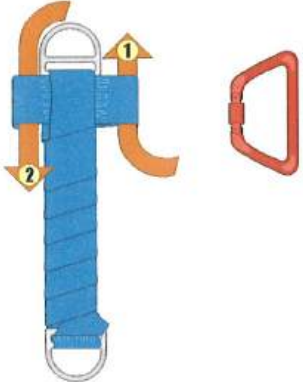



Figure 12-6: Prusik Brake Released

LRD Set-up (CMC ProSeries Load Release Strap)

The instructions below apply to the CMC ProSeries Load Release Strap only. Teams using other manufacturer's equipment must refer to specific manufacturer's information for safe set-up and use.

<p>Figure 12-8: Step 1</p>  <ol style="list-style-type: none"> 1. Pull the end of the strap until the floating D-ring is close to the end of the stitched section of the webbing. 	<p>Figure 12-9: Step 2</p>  <ol style="list-style-type: none"> 2. Wrap the webbing around itself until about 8" of webbing is left. 	<p>Figure 12-10: Step 3</p>  <ol style="list-style-type: none"> 3. Form a bight near the stitched section at the end of the strap.
<p>Figure 12-11: Step 4</p>  <ol style="list-style-type: none"> 4. Pass the bight through the strap as shown. 	<p>Figure 12-12: Step 5</p>  <ol style="list-style-type: none"> 5. Connect the bight and the stitched loop together with a carabiner. 	<p>Figure 12-13: Step 6</p>  <ol style="list-style-type: none"> 6. Finished LRD.

LRD Load Transfer

- Maintain control of the stitched loop at all times during load transfer.
 - Remove the carabiner that connects the stitched loop and the bight.
 - Pull the bight out of the LRD.
 - Slowly remove the wraps until the strap begins to slip.
 - Control movement until the load is transferred.

3. Main line.

- Reposition the haul cam as needed to clear the change of direction (COD) pulley. (Figure 12-

Figure 12-17: Reposition the Haul Cam

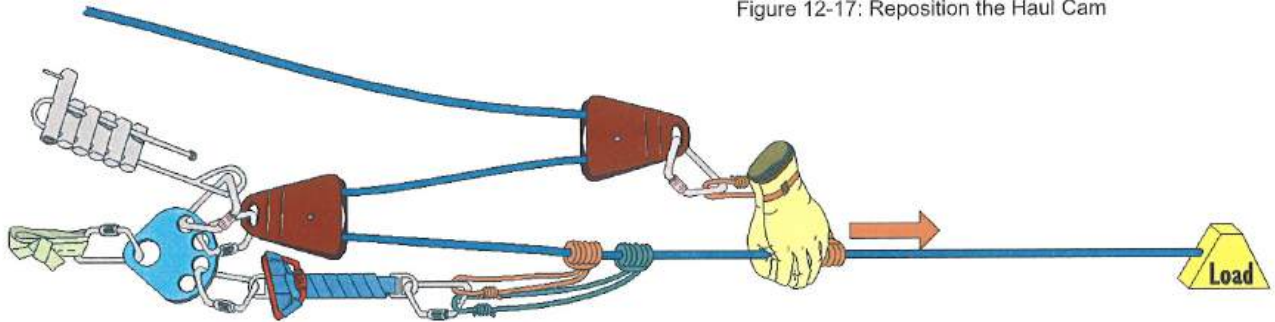

17)

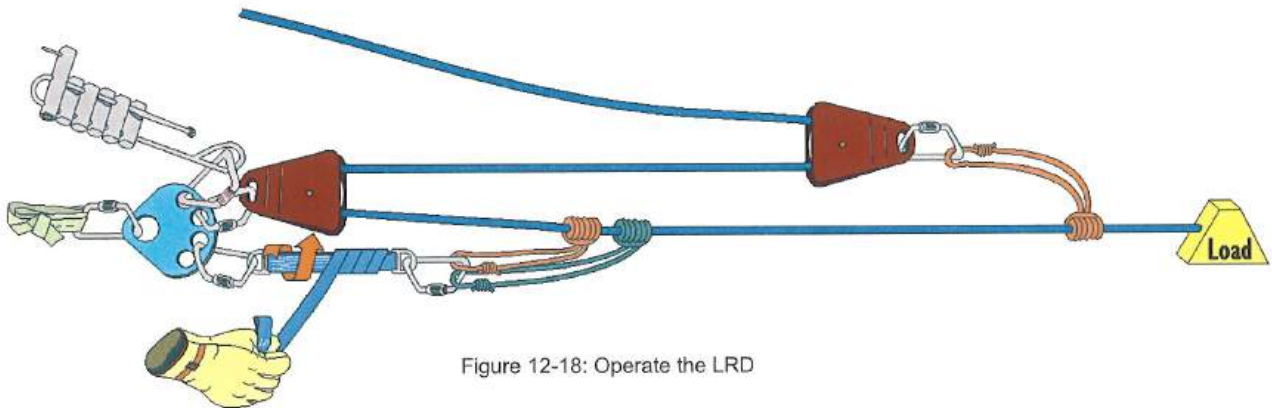

Figure 12-18: Operate the LRD

- Haul Team staffs the main line and maintains tension during the LRD operation.

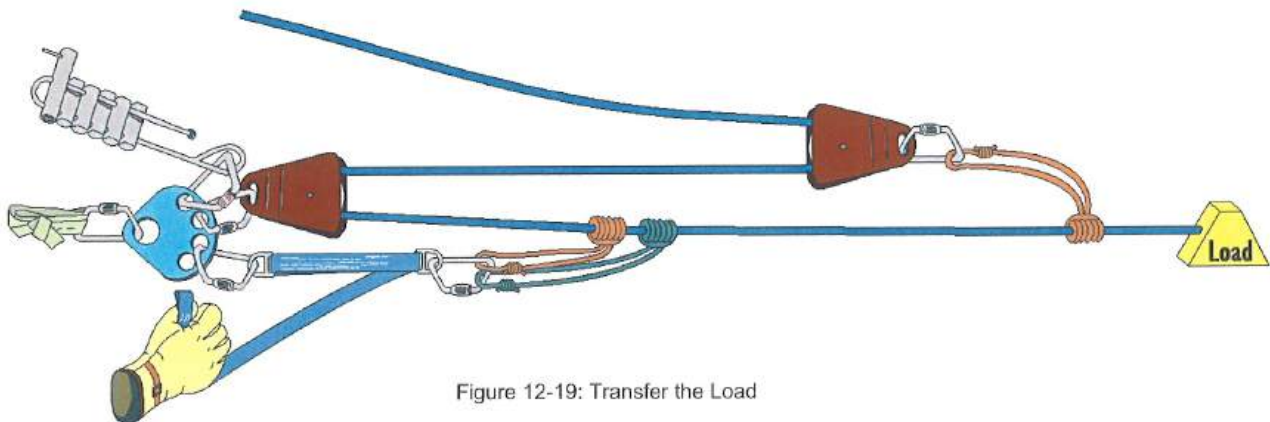

Figure 12-19: Transfer the Load

- Transfer the load according to manufacturer's instructions. (Figure 12-19)

Chapter 13: Rescue Scene Organization and Management

Scope: This chapter serves as an introduction to rescue scene organization and management.

Terminal Learning Objective (TLO): At the end of this chapter, the student will be aware of implementing a command structure, giving clear objectives and assignments, and coordinating the activities of the various responders.

Enabling Learning Objectives (ELO):

1. Describe rescue scene organization and management
2. Describe command and control in rope rescue operations
3. Describe rope rescue position descriptions
4. Describe ICS and rope rescue operations

For purposes of this course, it shall be assumed the student is familiar with the Incident Command System (ICS). Students not familiar with ICS are encouraged to take a separate ICS course.

The Incident Commander sets the tone for the successful management of the incident by implementing a command structure, giving clear objectives and assignments, and coordinating the activities of the various responders.

Command and Control in Low Angle Rope Rescue Operations

- The incident command system is the framework for managing any incident.
- Prior training in ICS is important so everyone knows where they fit into the system.
- ICS should be used to manage all phases of the rescue operation.
- Small incidents can be managed by one person wearing all the hats.
- The ICS expands as the incident grows to maintain an efficient span of control.
- Incidents that involve more than one jurisdiction may be managed by Unified Command.
- Positions that may need to be filled on an "typical" low angle rescue incident include:
 - Incident Commander (IC).
 - Safety Officer (this role may be retained by the IC).
 - Rescue Group Supervisor.
 - Assistant Safety Officer- Low Angle Rescue.
 - Rigging Team.
 - Haul Team.
 - Litter Team.
 - Edge Person.
 - Main Line Tender.
 - Belay/Safety Line Tender.
 - Rescuer(s).

ICS and Low Angle Rope Rescue Operations

First arriving responder assumes IC, performs size-up, and ensures adequate resources are requested. May initiate lowering operation or rappel operation to put a rescuer into contact with victims.

- Command may be transferred to more qualified personnel as they arrive.

- Ensures safety checks are performed as needed.

Assistant Safety Officer – Low Angle Rescue (ASO)

- Reports to the Incident Safety Officer.
- Coordinates with Rescue Group Supervisor.
- Must be competent in low angle rescue operations.
- Responsible for the technical accuracy and safety of the rope rescue operations.
- Oversees safety of actual low angle operations.
- Safety checks all components of lowering/raising system.
 - The person who safety checks the system components shall not be the person who rigged them.
 - When staffing is limited, personnel can safety-check each other's work.
 - Perform continuous safety checks.
 - Safety check AFTER the rescue team members are attached to main and safety BEFORE lines are loaded.

Rigging Team Leader

- Oversees rigging and operation of rope systems, ensures safety checks are completed.
- May move to another position after rigging is complete.

Rigger

- Assemble rope rescue systems in place.
- Riggers move into other positions after rigging is complete.

Edge Person

- Watches over edge for safety and coordination issues.
- Communication link between rescuers and Rescue Group Supervisor.

Mainline Tender (lowering)

- Operates rope and friction device to lower rescuers down the slope.

Belay/Safety Line Tender

- Operates belay/safety to ensure safety of personnel being lowered or raised by rope system.

Haul Team Leader

- Oversees operation of mechanical advantage haul system.

Hauler

- Controls mainline during raising operations.

Litter Team Leader

- Oversees operations including victim packaging and extraction.
- Safety checks rescuer and victim attachment to litter.

Considerations for the IC

☐ Apparatus spotting.

- Spot Engine 1 to protect personnel from traffic and to provide anchors for systems.
 - Minimum workspace.
 - Avoid placing the systems where dislodged debris may roll towards the victim.
 - Shut down the motor and lock-out/tag-out any vehicle used as a rope system anchor.

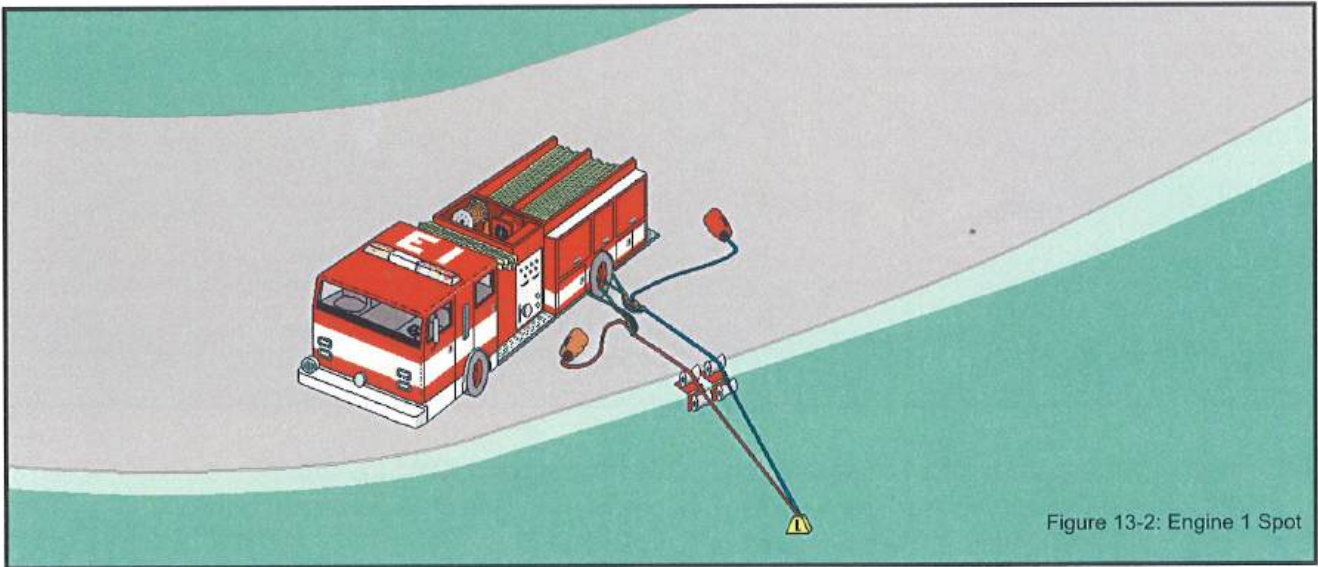

☐ Spot Engine 2 to protect personnel from traffic and to provide anchor for a change of direction system if used.

- Maximum length of rope for inline or piggyback systems.
 - Too short = multiple resets; too long = communication challenges.

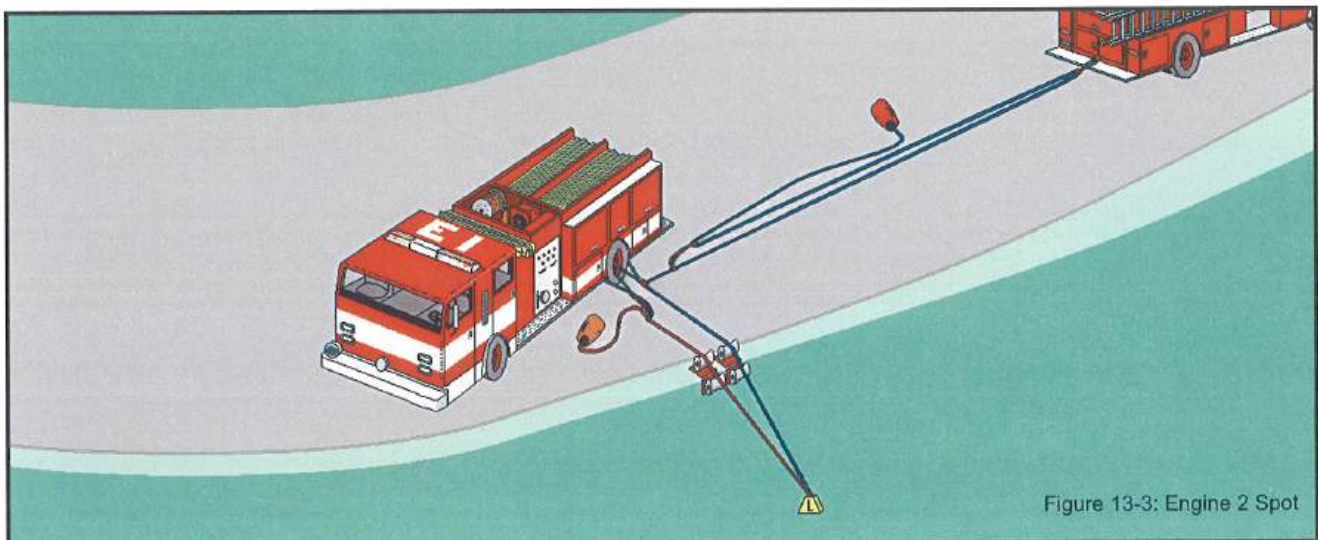

- Size-up.
 - Will ropes be utilized?
 - If rope system is to be used:
 - In line.
 - Directional change.
 - Piggyback.
 - Are sufficient personnel responding? (Includes filling necessary ICS functions and staffing haul and litter teams.)
 - Traffic control.
 - Consider staging resources until needed.
 - Establish objectives (DLAST).
 - Detect the victim(s).
 - ◆ Skid marks, sounds, etc to indicate the victim's rough location.
 - Locate the victim(s).
 - ◆ Confirm the actual location of the victim.
 - ◆ Distance from road or rescuer access point.
 - ◆ Alternative routes of access to victim.
 - Access the victim(s).
 - ◆ Rescuer may hike down to, rappel to, or be lowered to victim's location.
 - Stabilize the victim(s).
 - ◆ Package victim in harness or litter.
 - Transport the victim(s).
 - ◆ Using walkout or litter extraction.
 - Use standardized field commands for the local areas.
 - It is very beneficial to have cooperating agencies using the same standardized field commands.
 - Debriefing and documentation examples of information to gather and document may include the following timelines:
 - Rescue Operation: At scene, rescuer deployed, victim topside, rescuer topside, clear.
 - Patient care: 1st care, EMS hand-off, ALS care initiated, Time and method of transport.
 - Technical Operations: Lowering system distance, anchor(s) used, equipment and safety issues, training needs.
 - Scene Management: ICS used, SOP (or G) used, Overall evaluation.
 - Interagency effectiveness: communication, staging, interface.

- "MAIN LINE READY."
- Edge Person to the Rescuer.
 - "RESCUER READY?"
- When ready, Rescuer to Edge Person.
 - "READY."
- Operation commands.
 - Edge Person to Main Line Tender.
 - "DOWN."
 - To increase the lowering speed, the Edge Person calls out, "DOWN, DOWN."
 - To stop the operation, the Edge Person calls out, "STOP."
 - Any member of the crew who needs to stop the operation may call out, "STOP."

Raising System - Changeover from Lowering to Raising System

Crew Assignments

- Edge Person.
 - Coordinates the operation.
 - Gives orders.
 - Haul Team Leader.
 - Belay/Safety Line Tender.
- Haul Team Leader.
 - Manages the changeover from a lowering system to a raising system.
- Belay/Safety Line Tender.
 - Converts lowering belay to raising belay.

Operation of Raising System

Crew Assignments

- Edge Person.
 - Coordinates the operation.
 - Gives orders.
 - Haul Team Leader.
 - Belay/Safety Line Tender.
 - Rescuer.
- Haul Team Leader.
 - Directs the Haul Team on the main line to raise the Rescuer/victim.
- Belay/Safety Line Tender.
 - Manages the belay system.

- Any member of the crew who needs to stop the operation may call out, "STOP."
- To disconnect rescuer/victim.
 - Provide slack.
 - ◆ Main line.
 - Release ratchet prusik.
 - ◆ Belay/safety line.

Example Organization of a Low Angle Rescue Using 3-Person Engines

First Arrival Considerations

- Size-up.
 - Location of patient.
 - Shape of terrain.
 - Resource needs.
 - Staffing.
- Anchor system.
 - Natural.
 - Adequate.
 - System compatible for directional on inline operations.
 - Vehicle.
 - Wheels.
 - Hooks.
 - ◆ Provide adequate workspace.
 - ◆ MA direction/layout.
 - ◆ Placement.

Step #1: Scene Assessment and Rigging

First Engine

- E1 Company Officer: Incident Commander/Safety Officer/Rigging Team Leader.
- E1 Fire Fighter 1: Rigger.
- E1 Fire Fighter 2: Rigger/Rescuer.
- Attach RPM.
 - Provide edge protection.
 - Bag (prerig) layout.
- Package and attach rescuer (E1 Fire Fighter 2).
 - Mandatory safety check.

Sample Organization Chart

May be revised as needed depending on the incident.

Step 1: Scene Assessment and Rigging

Positions shown in parenthesis are filled or retained by a person filling multiple positions.

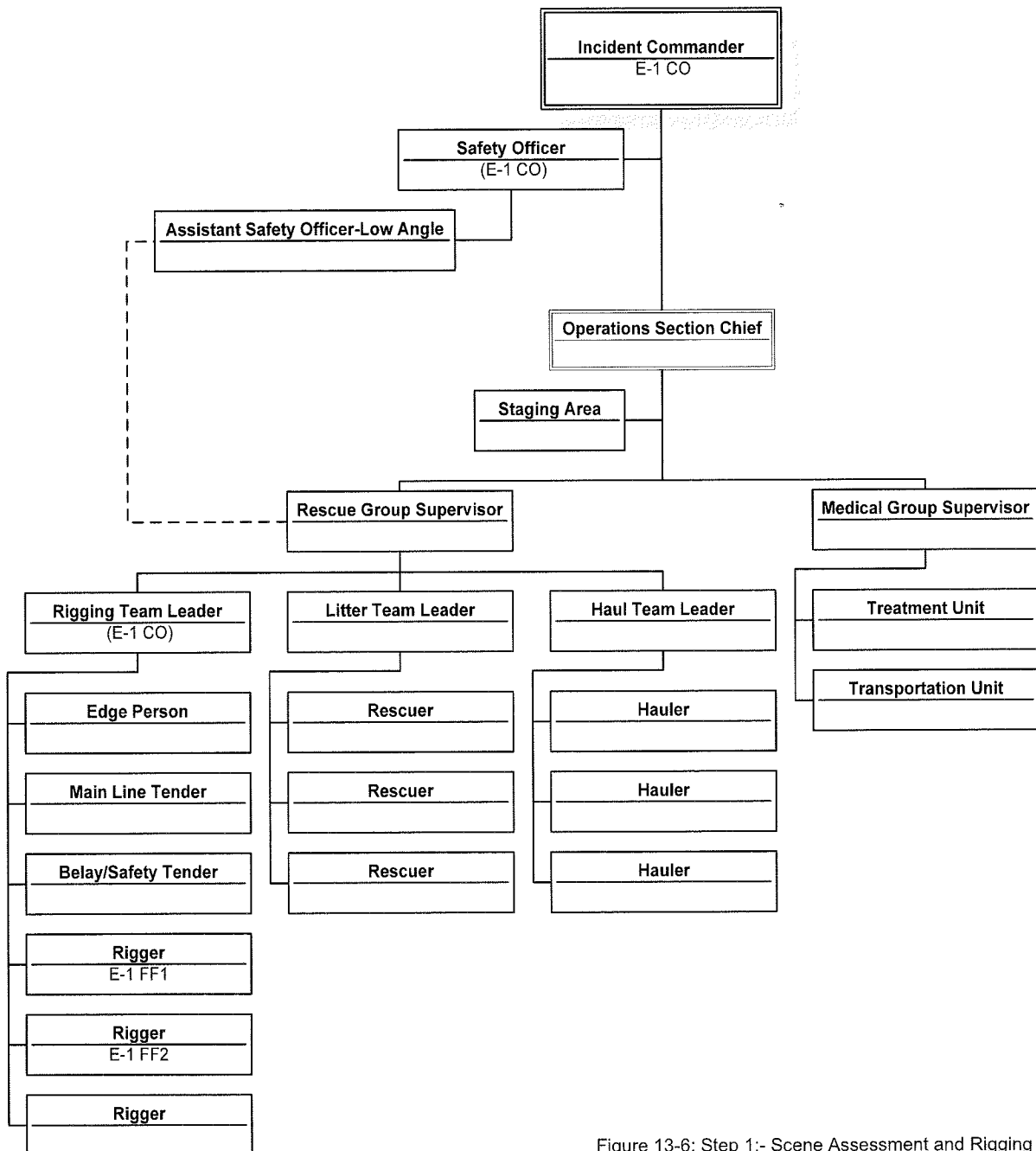

Figure 13-6: Step 1:- Scene Assessment and Rigging

Step 3: Ambulatory Victim Walkout

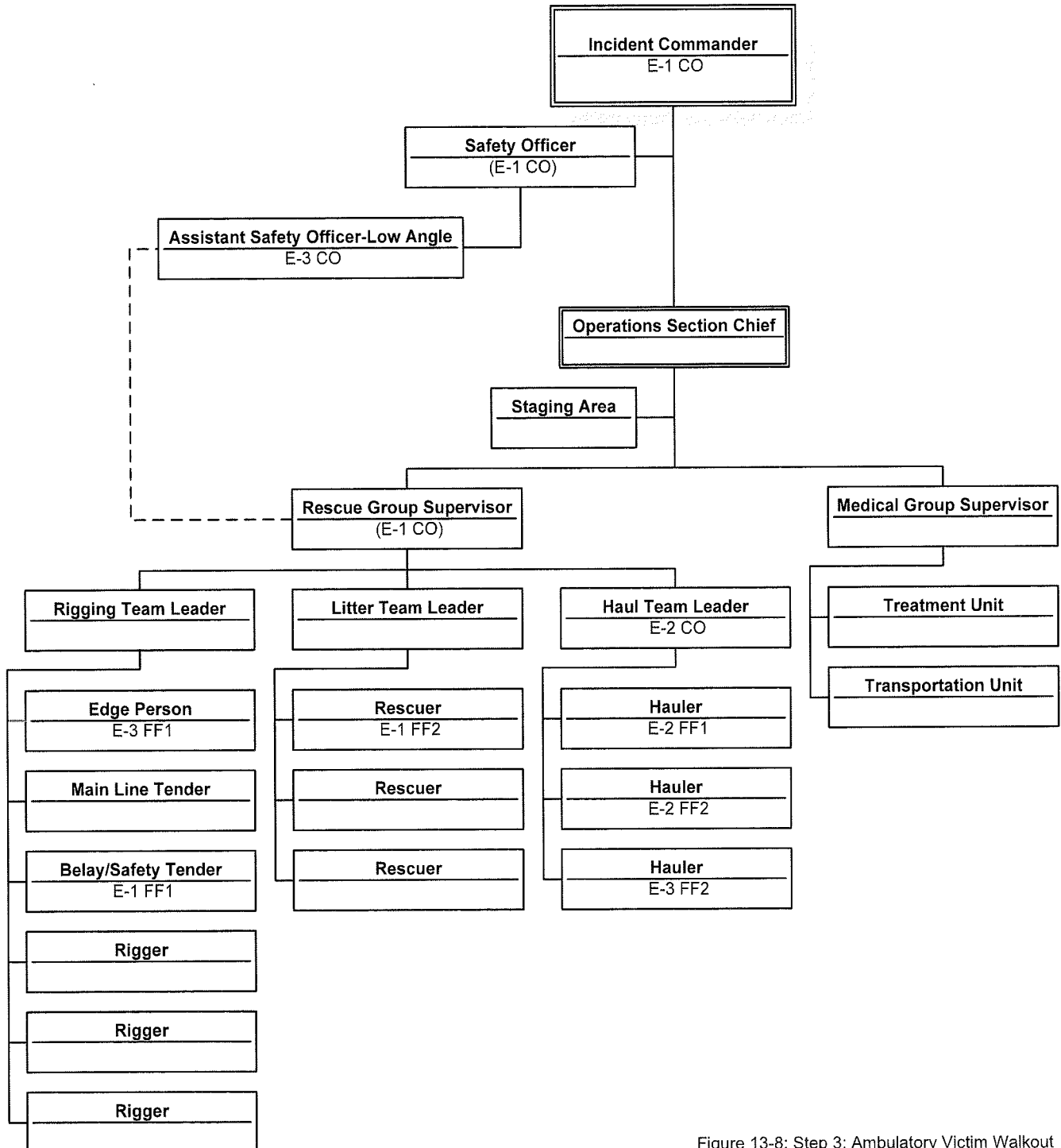

Figure 13-8: Step 3: Ambulatory Victim Walkout

Step 5: Nonambulatory Victim Rescue

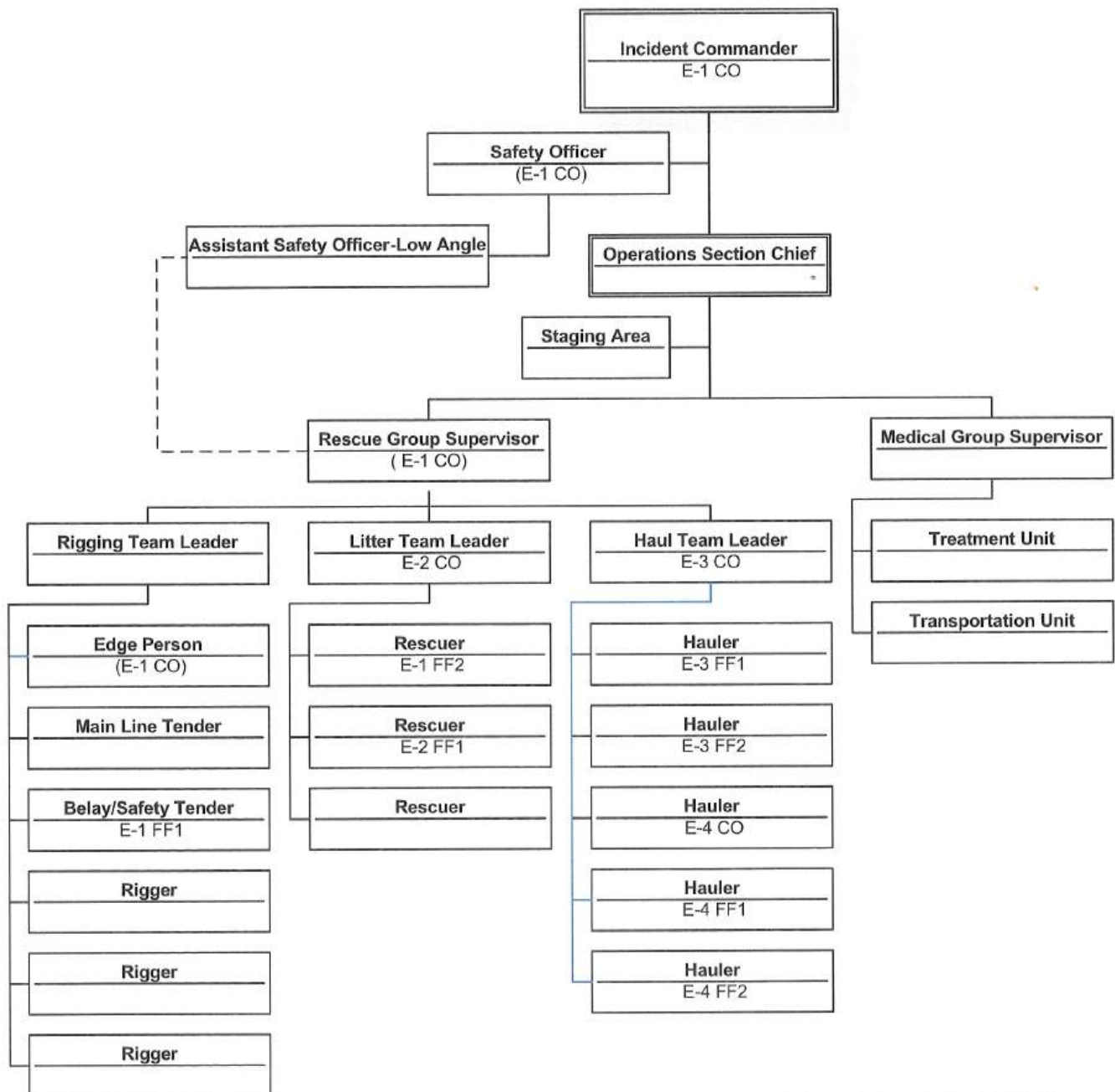

Figure 13-10: Step 5: Nonambulatory Victim Rescue

Chapter 14: Litter Walkouts

Scope: This *optional* chapter serves as an introduction to litter walkouts.

Terminal Learning Objective (TLO): At the end of this *optional* chapter, the student will be aware of techniques for litter walkouts that will provide a stable platform for the rescue team and ensure the safe transport of the victim.

Enabling Learning Objectives (ELO):

1. Demonstrate a single litter walkout
2. Demonstrate a caterpillar technique, single litter
3. Demonstrate a single litter with belay, single and multiple pitch
4. Demonstrate a single litter with belay, multiple pitch

There are times when a mechanical advantage system is not required to safely evacuate a nonambulatory victim, but terrain and distance can present slip or trip hazards for litter attendants. In these situations using the techniques described below for litter walkouts will provide a stable platform for the rescue team and ensure the safe transport of the victim. Examples of terrain environments that contribute to this situation are:

- Winding narrow trails.
- Gentle to moderate terrain changes.
- Gentle stream crossings.
- Mossy rocks.
- Ice and snow.
- Heavy forest litter.
- Disaster debris.

This chapter will address the following four litter walkout operations:

- ① Simple walkout.
- ② Caterpillar walkout.
- ③ Single pitch walkout with a belay/safety line.
- ④ Multiple pitch walkout with a belay/safety line.

The Simple Walkout

During a litter walkout, only the litter attendants provide support and movement to the litter and victim. The rescuers carry the litter over or around obstacles that are easily stepped over or across.

Key Points

- Do not walk in step; this may cause the litter to bounce.
- Rotate and rest positions as needed.
- Communicate ground conditions and hazards to team members.
- The litter and attendants move together as one unit over the terrain.

Key Points

- Used with both simple walkout and caterpillar operations.
- The belay/safety line is for the litter only.
- If the belay/safety line begins to support the rescuer's weight or haul the litter, then setup either for a two line low angle rope system or find a new route.
- The length of the walkout will not exceed the length of the belay/safety line.

The Multiple Pitch Walkout with a Belay/Safety Line

Often an uphill, downhill, or traversing litter walkout can be broken down into short sections called pitches. This breakdown gives the rescue team a way in which to plan regular rests and patient reassessments. Often, belay/safety lines will be utilized if the litter walkout has been organized into pitches. A pitch's length will depend on several variables:

- Pitches should start and end at natural flat rest spots along the trail if possible.
- Pitches should be organized to provide rests for litter team before and after strenuous sections of trail.
- If a belay/safety line is used, pitches will be determined by rope length and anchor availability.

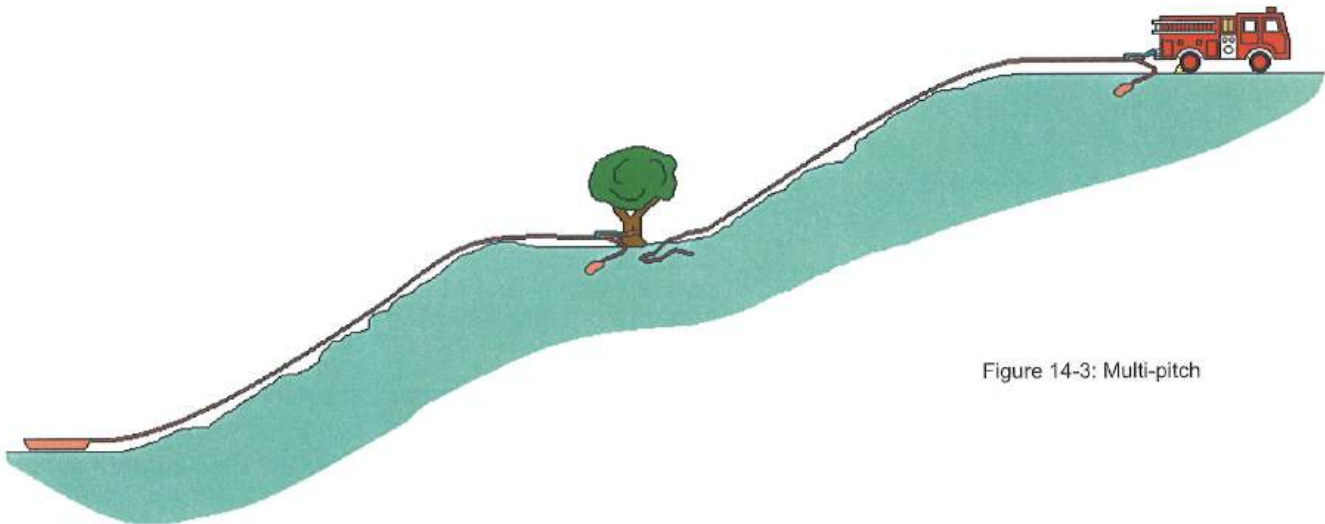

Figure 14-3: Multi-pitch

Key Points

- Attach new belay/safety line before disconnecting previous line.
- Use change over location to check victim.
- Use change over location to rest and rotate rescuers.

Staffing

There are four basic positions to be filled by litter team members during litter walkout operations.

- Belay/Safety Line Attendant.
 - Tends belay/safety line.
 - Position can be filled by Rigger.
- Additional team members.
 - Carry additional gear and equipment.
 - Relieve other Litter Attendants.
 - Be ready to assist with maneuvering litter over/around obstacles.

Ladders used in Litter Walkouts

Ladders are often used in litter walkouts. When used in this fashion, the ladder is used to distribute the weight of the litter to more rescuers. It also provides the ability for the litter team to more easily negotiate small spans, changes in elevation, and uneven terrain. A more complete description of ladders used in low angle rescue situations can be found in Chapter 15.

when you need to cross several spans that have similar distances. A litter is attached to a fire service ladder. The attachment is done by lashing the litter rail to the ladder rung with 1" webbing.

Configurations

Two moving ladder slide configurations are shown in this chapter. The litter may be lashed at the butt end of the ladder when negotiating grade changes and/or obstacles. When operating on level ground, the litter is lashed at the center of the ladder.

Considerations

- Number of personnel available.
 - Can be as few as four.
- The need for a moving ladder slide.
 - Spread load due to weight or duration of carry.
 - Span obstacles.
 - Distance to travel.
- Applications.
 - Horizontal terrain and obstacles to traverse.
 - Vertical terrain and obstacles to traverse.

Components

- One straight ladder or roof ladder.
- One rescue litter.
- Webbing for litter lashing.
 - Two 15-foot sections of webbing.

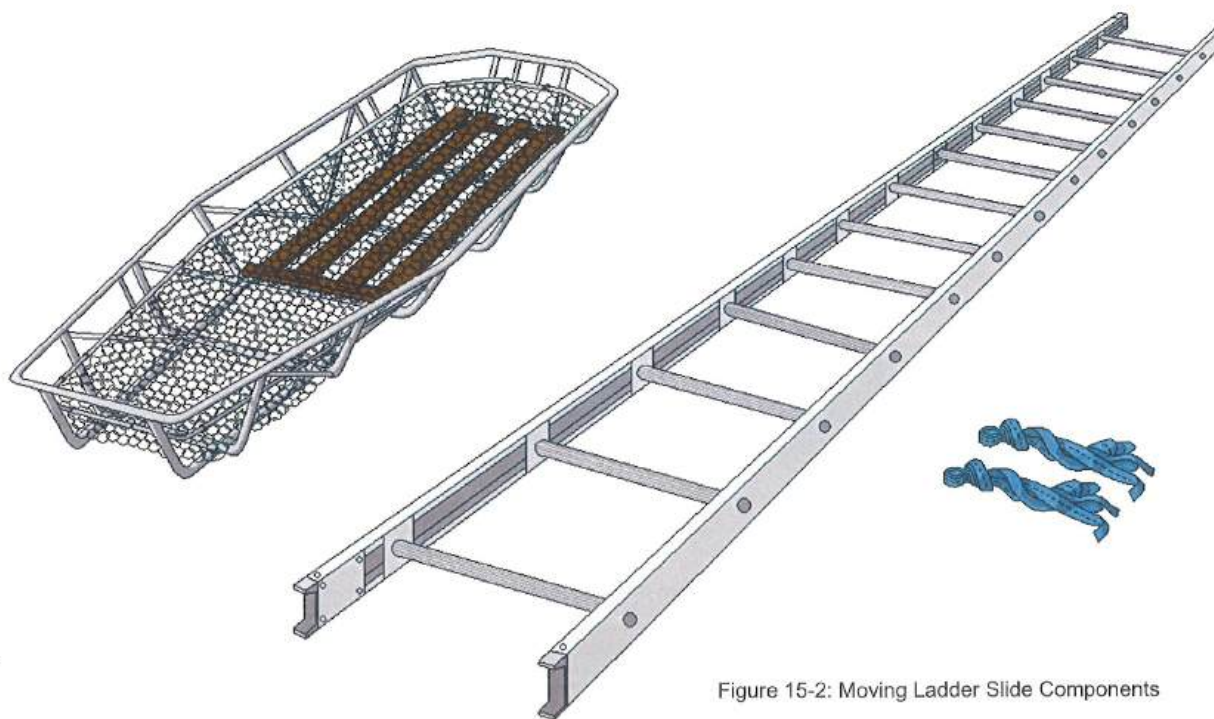

Figure 15-2: Moving Ladder Slide Components

Operations

- Lifting the basket.
- Raising the basket.
- System is levered over.

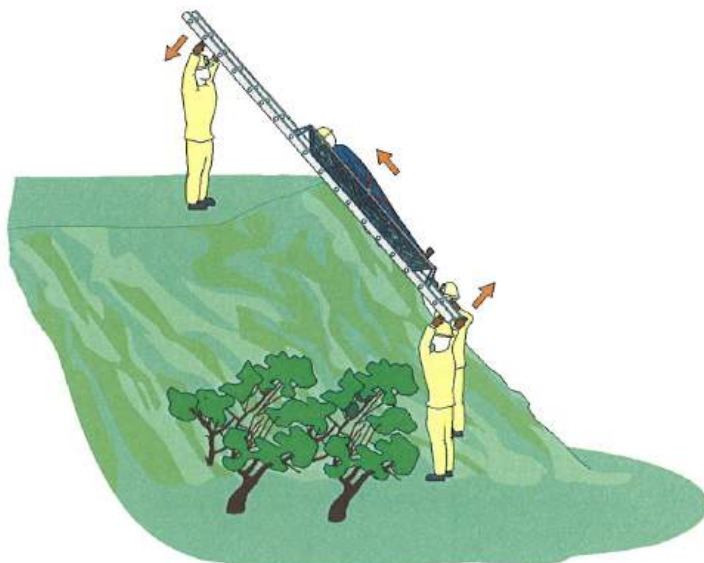

Figure 15-6: Levering the System

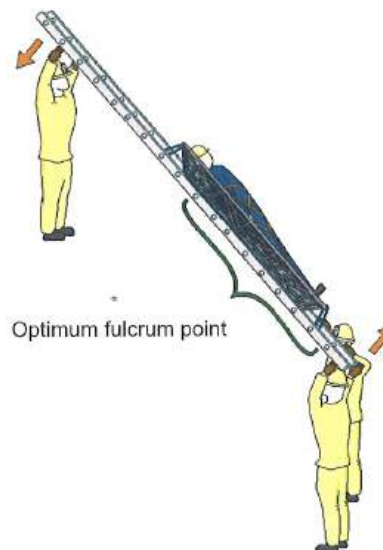

Figure 15-7: Swing System Up and Out

Precautions

- Lash the litter to the foot end of the ladder for vertical applications. This prevents interference from the hooks of a roof ladder.
- Be aware of where the fulcrum point is located when levering the ladder. (Figure 15-7)

Constructing a Moving Ladder Slide for Level Ground Walkouts

1. Mount the rescue litter in the middle of the ladder.
2. Tie a round turn and two half hitches to the rung. (Figure 15-5)
3. Wrap a minimum of six times.
4. The webbing should create a wide, stable fan.
5. Anchor the webbing to the rung using a round turn and two half hitches.
6. Lash the head of the litter to a corresponding rung in the same manner.

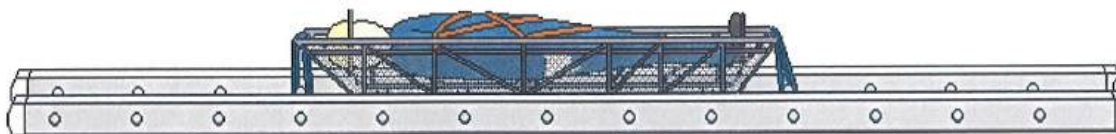

Figure 15-8: Level Ground Walkout (Litter in the Middle)

Considerations

- Number of personnel available.
- Equipment available.
- The need for a ladder slide.
- The need for a more complex rope system.
- Distance to move the victim.

Components

- One (1) straight ladder or extension ladder.
- One (1) 12-foot section of webbing for stabilizing the tip of the ladder.
- One (1) rescue litter.
- Head lashing for litter.
 - One (1) green or yellow webbing sling.
- Interior and exterior victim lashing.
 - Three (3) 20-foot webbing slings
- Belay/safety line system.
 - One (1) anchor sling.
 - Two (2) carabiners.
 - One (1) load-releasing device.
 - Tandem prusiks.
 - Lifeline.
- Mechanical advantage system.
 - One (1) anchor sling.
 - Two (2) pulleys.
 - Two (2) carabiners.
 - Lifeline.

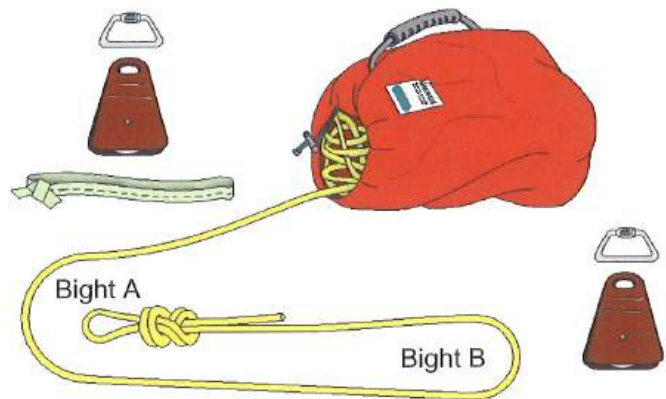

Figure 15-11: 2:1 Ladder Rig Components

Constructing a 2:1 Ladder Rig

1. Tie a figure eight on a bight with a 4" loop in the end of the line.
2. Place rope on the ground, forming two bights as shown above.
3. Place bight "B" into pulley and connect a carabiner to this pulley.
4. Connect the load to this carabiner (head lashing of the litter).
5. Place bight "A" into pulley and connect a carabiner to this pulley.
6. Secure figure eight on a bight into this carabiner on top of the pulley.
7. Connect this carabiner to the anchor sling.

- Fly in for raises.

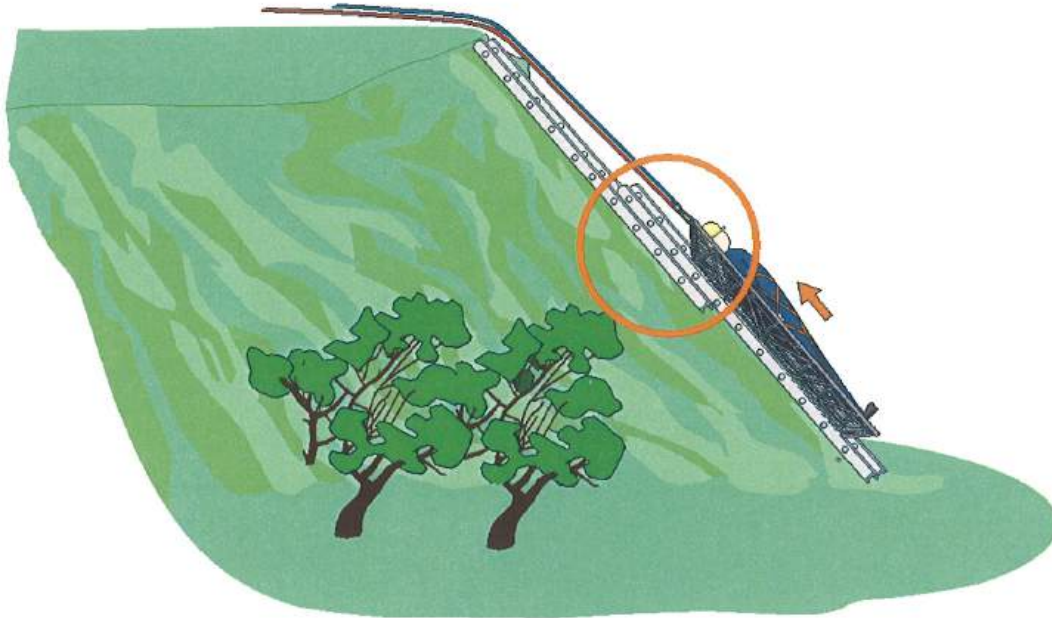

Figure 15-14: Fly In for Raises

- Position the ladder just below the edge of the departure point.
- Tie off the halyard if the ladder is extended and or use webbing to secure. (Figure 15-15)
- Secure the ladder using webbing or rope (12-15 feet).
 - Rescuers may foot the ladder if the terrain permits.

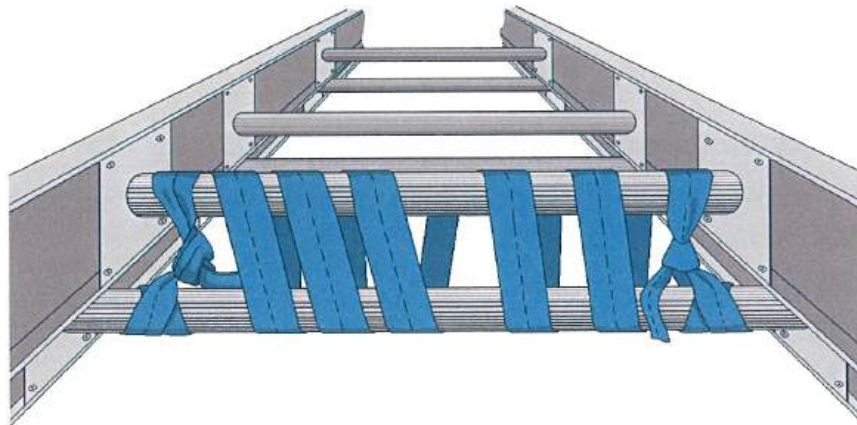

Figure 15-15: Lash Fly to the Bed of the Extension Ladder

- Build the main line and belay/safety line systems.
 - Friction device for lowering.
 - Mechanical advantage system for raising.

Chapter 16: Evolutions

Scope: This chapter serves as an opportunity for students perform in low angle rope rescue situations.

Terminal Learning Objective (TLO): At the end of this chapter, the student will be to apply what they have learned and for the instructors to assess the students' understanding and skill.

Enabling Learning Objectives (ELO):

1. Demonstrate how to access, stabilize, and package an ambulatory victim for a low angle walkout (one rescuer)
2. Demonstrate how to access, stabilize, package, and rescue a nonambulatory victim (3 litter tenders and 4 litter tenders)
3. Demonstrate how to access, stabilize, package, and rescue multiple ambulatory and nonambulatory victims (combination)

During the evolution phase of the Low Angle Rope Rescue course, a variety of different evolutions may be developed and used by the instructor to provide opportunities for the students to apply what they have learned and for the instructors to assess the students' understanding and skill.

Evolution Components

Mechanical Advantage Systems

- 3:1 inline – RPM.
- 3:1 inline with directional pulley.
- 3:1 pig rig.
- 5:1 inline – RPM.
- 5:1 inline with directional pulley.
- 5:1 pig rig.

Victim Packaging

- Ambulatory victim using commercial and hasty harnesses.
- Nonambulatory victim lashing in a rescue litter using webbing.

Rescuer Packaging

- Class II commercial harness.
- 3 litter tenders.
- 4 litter tenders.

Anchor Systems

- Inline system using fire apparatus as an anchor.
- Two fire apparatus as anchors using a change of direction system.
- Triangle picket anchor.
- 1-1-1 inline picket system.

NOTE: Four sample evolutions are included that provide the students the opportunity to apply the various skills listed above. Additional sample optional evolutions are included that are designed to provide the students the opportunity to practice ladder and litter walkout skills.

EVOLUTION #1

EVOLUTION #1:

Access, Stabilize, and Package an Ambulatory Victim for a Low Angle Walkout (One Rescuer)

The students will perform size-up, build an appropriate rope system, lower a rescuer to stabilize, package, and raise an ambulatory victim using a mechanical advantage rope system.

TIME FRAME:

1:15

STUDENTS (MINIMUM):

One (1) squad: 12 students

MATERIALS NEEDED:

- One (1) LARR OPERATIONAL rope cache
- One (1) fire apparatus
- One (1) victim harness

SITE PREPARATIONS:

Low angle site to be checked and cleared of all potential hazards, i.e., vehicle traffic, loose rocks/debris, vectors, and poisonous plants. Cache all equipment not to interfere with safety of operations.

INSTRUCTOR DIRECTIONS:

1. Review all Low Angle Rope Rescue Operational chapters.
2. Review operations and safety considerations with the students.
3. Review the desired goal and operation of this evolution with the students.
4. Break the students into operational positions according to the organizational chart.

STUDENT DIRECTIONS:

1. Size-up scene.
2. Determine the location to best access the victim.
3. Determine your anchor points on the fire apparatus.
4. Build the appropriate rope system.
5. Package the rescuer.
6. Attach the rescuer to the rope system.
7. Lower rescuer to the victim.
8. Rescuer assesses and stabilizes the victim.
9. Rigger(s) apply a 3:1 mechanical advantage to the rope system and prepare for the raising operation.
10. Rescuer packages the victim.
11. Rescuer attaches the victim to the rope system.

EVOLUTION #2

EVOLUTION #2:

Access, Stabilize, Package, and Rescue a Nonambulatory Victim
(3 Litter Tenders)

The students will perform size-up, build an appropriate rope system, lower three rescuers attached to a rescue litter and rope system to stabilize, package, and rescue a nonambulatory victim using a mechanical advantage rope system.

TIME FRAME:

1:15

STUDENTS (MINIMUM):

One (1) squad: 12 students

MATERIALS NEEDED:

- One (1) LARR OPERATIONAL rope cache
- One (1) rescue litter
- One (1) victim (rescue mannequin or person)
- Two (2) fire apparatus

SITE PREPARATIONS:

Low angle site to be checked and cleared of all potential hazards, i.e., vehicle traffic, loose rocks/debris, vectors, and poisonous plants. Cache all equipment not to interfere with safety of operations.

INSTRUCTOR DIRECTIONS:

1. Review all Low Angle Rope Rescue Operational chapters.
2. Review operations and safety considerations with the students.
3. Review the desired goal and operation of this evolution with the students.
4. Break the students into operational positions according to the organizational chart.

STUDENT DIRECTIONS:

1. Size-up scene.
2. Determine the location to best access the victim.
3. Determine your anchor points on the fire apparatus.
4. Build the appropriate rope system.
5. Package the rescuers.
6. Attach rescuers to the rescue litter and rope system.
7. Lower rescuers to the victim.
8. Rescuers assess and stabilize the victim.
9. Rigger(s) apply a 3:1 mechanical advantage with directional pulley to the rope system and prepare for the raising operation.
10. Rescuers package the victim in the rescue litter.

EVOLUTION #3

EVOLUTION #3:

Access, Stabilize, Package, and Rescue a Nonambulatory Victim
(4 Litter Tenders)

The students will perform size-up, build an appropriate rope system, lower four rescuers and a rescue litter with a rope system to stabilize, package, and rescue a nonambulatory victim using a mechanical advantage rope system.

TIME FRAME:

1:15

STUDENTS (MINIMUM):

One (1) squad: 12 students

MATERIALS NEEDED:

- One (1) LARR OPERATIONAL rope cache
- One (1) rescue litter
- One (1) victim (rescue mannequin or person)
- Fifteen (15) pickets

SITE PREPARATIONS:

Low angle site to be checked and cleared of all potential hazards, i.e., vehicle traffic, loose rocks/debris, vectors, and poisonous plants. Cache all equipment not to interfere with safety of operations.

**INSTRUCTOR
DIRECTIONS:**

1. Review all Low Angle Rope Rescue Operational chapters.
2. Review operations and safety considerations with the students.
3. Review the desired goal and operation of this evolution with the students.
4. Break the students into operational positions according to the organizational chart.

STUDENT DIRECTIONS:

1. Size-up scene.
2. Determine the location to best access the victim.
3. Determine your anchor points.
4. Construct the anchor system using pickets.
5. Build the appropriate rope system.
6. Package the rescuers.
7. Lower one (1) rescuer to assess scene and initiate care.
8. Attach remaining three (3) rescuers to the rescue litter and rope system.
9. Lower rescuers to the victim.

EVOLUTION #4 (COMBINATION OPTION)

EVOLUTION #4:

Access, Stabilize, Package, and Rescue Multiple Ambulatory and Nonambulatory Victims

The students will perform size-up, build an appropriate rope system, lower a rescuer to access the victims, communicate needs, lower additional rescuers and equipment to stabilize, package, and rescue at least one ambulatory victim and one nonambulatory victim using a mechanical advantage rope system.

TIME FRAME:

2:00

STUDENTS (MINIMUM):

One (1) squad: 12 students

MATERIALS NEEDED:

- One (1) LARR OPERATIONAL rope cache
- One (1) rescue litter
- One (1) victim harness
- One (1) victim (rescue mannequin or person)
- Fifteen (15) pickets

SITE PREPARATIONS:

Low angle site to be checked and cleared of all potential hazards, i.e., vehicle traffic, loose rocks/debris, vectors, and poisonous plants. Cache all equipment not to interfere with safety of operations.

INSTRUCTOR DIRECTIONS:

1. Review all Low Angle Rope Rescue Operational chapters.
2. Review operations and safety considerations with the students.
3. Review the desired goal and operation of this evolution with the students.
4. Break the students into operational positions according to the organizational chart.

STUDENT DIRECTIONS:

1. Size-up scene.
2. Determine the location to best access the victims.
3. Determine your anchor points.
4. Build the appropriate rope system.
5. Package the rescuers.
6. Attach Rescuer #1 to the rope system.
7. Lower Rescuer #1 to the victims.
8. Rescuer #1 assesses and stabilizes the victims, then communicates his or her needs to the other rescuers.

EVOLUTION #4:

Access, Stabilize, Package, and Rescue Multiple Ambulatory and Nonambulatory Victims

28. When evolution is complete, inspect, and cache all equipment.
29. Critique the evolution.

OPTIONS

- a. Consider rotating students through different positions during the evolution.
- b. Consider using both commercial and improvised packaging equipment (victim harness, hasty harness, spider straps, webbing as lashing).
- c. Consider using a car as part of the scenario, placing victims in the car, and treating them as motor vehicle accident victims.
- d. Follow local protocols and utilize backboards and other appropriate medical equipment to provide spinal immobilization for nonambulatory victim(s).

EVOLUTION #5 (OPTIONAL)

EVOLUTION #5:

Access, Stabilize, Package, and Rescue a Nonambulatory Victim Using Both a Single Litter Walkout and Caterpillar Techniques

The students will perform size-up, access, stabilize, package, select route, and rescue a nonambulatory victim using a combination of single litter walkout and caterpillar techniques.

TIME FRAME:

0:30

STUDENTS (MINIMUM):

One (1) squad: 12 students

MATERIALS NEEDED:

- One (1) LARR OPERATIONAL rope cache
- One (1) rescue litter
- One (1) victim (rescue mannequin or person)

SITE PREPARATIONS:

Low angle site to be checked and cleared of all potential hazards, i.e., vehicle traffic, loose rocks/debris, vectors, and poisonous plants. Cache all equipment not to interfere with safety of operations.

INSTRUCTOR DIRECTIONS:

1. Review all Low Angle Rope Rescue Operational chapters.
2. Review operations and safety considerations with the students.
3. Review the desired goal and operation of this evolution with the students.
4. Break the students into operational positions according to the text.

STUDENT DIRECTIONS:

1. Size-up scene.
2. Determine the location to best access the victim.
3. Litter Team accesses victim without the use of ropes.
4. Determine best route to evacuate victim.
5. Litter Team secures victim into rescue litter.
6. Scout ahead of litter team.
7. Scout advises Litter Team of route and potential slip or trip hazards.
8. Move litter and victim along scouted route.
9. Rotate positions of Litter Team as needed.
10. Scout advises Litter Team of obstacle needing caterpillar technique.

EVOLUTION #6 (OPTIONAL)

EVOLUTION #6:

Access, Stabilize, Package, and Rescue a Nonambulatory Victim Using a Litter Walkout with a Single Pitch Belay

The students will perform size-up, access, stabilize, package, select route, and rescue a nonambulatory victim using a litter walkout with a single pitch belay.

TIME FRAME:

0:30

STUDENTS (MINIMUM):

One (1) squad: 12 students

MATERIALS NEEDED:

- One (1) LARR OPERATIONAL rope cache
- One (1) rescue litter
- One (1) victim (rescue mannequin or person)

SITE PREPARATIONS:

Low angle site to be checked and cleared of all potential hazards, i.e., vehicle traffic, loose rocks/debris, vectors, and poisonous plants. Cache all equipment not to interfere with safety of operations.

INSTRUCTOR DIRECTIONS:

1. Review all Low Angle Rope Rescue Operational chapters.
2. Review operations and safety considerations with the students.
3. Review the desired goal and operation of this evolution with the students.
4. Break the students into operational positions according to the text.

STUDENT DIRECTIONS:

1. Size-up scene.
2. Determine the location to best access the victim.
3. Litter Team accesses victim without the use of ropes.
4. Litter Team secures victim into rescue litter.
5. Rigging Team secures suitable anchor upslope from Litter Team and establishes a belay/safety line.
6. Belay/safety line is extended to Litter team.
7. Belay safety line is attached to rescue litter.
8. Litter Team confirms the belay/safety line is ready, and begins to carry the litter upslope.
9. Rigging Team tends the belay/safety line as the Litter Team walks upslope, maintaining less than two (2) feet of slack in line.
10. A single pitch walkout evolution concludes at the top of the slope.

EVOLUTION #7 (OPTIONAL)

EVOLUTION #7:

Access, Stabilize, Package, and Rescue a Nonambulatory Victim Using a Litter Walkout with Multiple Pitch Belay

The students will perform size-up, access, stabilize, package, select route, and rescue a nonambulatory victim using a litter walkout with multiple pitch belay.

TIME FRAME:

0:30

STUDENTS (MINIMUM):

One (1) squad: 12 students

MATERIALS NEEDED:

- One (1) LARR OPERATIONAL rope cache
- One (1) rescue litter
- One (1) victim (rescue mannequin or person)

SITE PREPARATIONS:

Low angle site, suitable for walkout and caterpillar evolutions, to be checked and cleared of all potential hazards, i.e., vehicle traffic, looser rocks/debris, vectors, and poisonous plants. Cache all equipment not to interfere with safety of operations.

INSTRUCTOR DIRECTIONS:

1. Review all Low Angle Rope Rescue Operational chapters.
2. Review operations and safety considerations with the students.
3. Review the desired goal and operation of this evolution with the students.
4. Break the students into operational positions according to the text.

STUDENT DIRECTIONS:

1. Size-up scene.
2. Determine the location to best access the victim.
3. Litter Team accesses victim without the use of ropes.
4. Litter Team secures victim into rescue litter.
5. Rigging Team secures suitable anchors upslope from litter.
6. Belay/safety lines are extended.
7. First belay/safety line is attached to the rescue litter.
8. Litter Team confirms the belay/safety line is ready, and begins to carry litter upslope.
9. Rigging Team tends the belay/safety line as the Litter Team walks upslope, maintaining less than two (2) feet of slack in line.
10. Upon arriving at a rest spot on the trail, lower the litter to the

EVOLUTION #8 (OPTIONAL)

<i>EVOLUTION #8:</i>	<p>Access, Stabilize, Package, and Rescue a Nonambulatory Victim using a Moving Ladder Slide</p> <p>The students will perform size-up, access, stabilize, package, and rescue a nonambulatory victim using a moving ladder slide.</p>
<i>TIME FRAME:</i>	1:15
<i>STUDENTS (MINIMUM):</i>	One (1) squad: 12 students
<i>MATERIALS NEEDED:</i>	<ul style="list-style-type: none"> • One (1) LARR OPERATIONAL rope cache • One (1) rescue litter • One (1) victim (rescue mannequin or person) • One (1) 14-foot ladder
<i>SITE PREPARATIONS:</i>	<p>Low angle site to be checked and cleared of all potential hazards, i.e., vehicle traffic, loose rocks/debris, vectors, and poisonous plants. Cache all equipment not to interfere with safety of operations.</p>
<i>INSTRUCTOR DIRECTIONS:</i>	<ol style="list-style-type: none"> 1. Review all Low Angle Rope Rescue Operational chapters. 2. Review operations and safety considerations with the students. 3. Review the desired goal and operation of this evolution with the students. 4. Break the students into operational positions according to the organizational chart.
<i>STUDENT DIRECTIONS:</i>	<ol style="list-style-type: none"> 1. Size-up the scene. 2. Determine the location to best access the victim. 3. Place the ladder on the slope. 4. Half of the rescuers descend the ladder to the victim. 5. Rescuers assess and stabilize the victim. 6. Rescuers package the victim in the rescue litter. 7. Rescuers place the ladder on flat ground. 8. Rescuers lash rescue litter to the ladder. 9. Rescuers lift and pass the moving ladder and victim. 10. When evolution is complete, inspect, and cache all equipment. 11. Critique the evolution.

EVOLUTION #9 (OPTIONAL)

EVOLUTION #9:	<p>Access, Stabilize, Package, and Rescue a Nonambulatory Victim using a Ladder Slide</p> <p>The students will perform size-up, access, stabilize, package, and rescue a nonambulatory victim using a ladder slide.</p>
TIME FRAME:	1:15
STUDENTS (MINIMUM):	One (1) squad: 12 students
MATERIALS NEEDED:	<ul style="list-style-type: none"> • One (1) LARR OPERATIONAL rope cache • One (1) rescue litter • One (1) victim (rescue mannequin or person) • One (1) 24-foot ladder
SITE PREPARATIONS:	<p>Low angle site to be checked and cleared of all potential hazards, i.e., vehicle traffic, loose rocks/debris, vectors, and poisonous plants. Cache all equipment not to interfere with safety of operations.</p>
INSTRUCTOR DIRECTIONS:	<ol style="list-style-type: none"> 1. Review all Low Angle Rope Rescue Operational chapters. 2. Review operations and safety considerations with the students. 3. Review the desired goal and operation of this evolution with the students. 4. Break the students into operational positions according to the organizational chart.
STUDENT DIRECTIONS:	<ol style="list-style-type: none"> 1. Size-up scene. 2. Determine the location to best access the victim. 3. Determine your anchor points. 4. Place and secure the ladder. 5. Build the appropriate rope system. 6. Package the rescuers. 7. Attach the litter to the rope system. 8. Rescuers descend the ladder with the litter to the victim. 9. Rescuers assess and stabilize the victim. 10. Rigger(s) apply a mechanical advantage to the rope system and prepare for the raising operation. 11. Rescuers package the victim in the rescue litter.

Appendix A: Student Task Book

The Low Angle Rope Rescue Operational Student Task Book lists every student requirement that will be observed, evaluated, and recorded by the Primary Instructor. Students who successfully meet the performance standards for this course will receive a course completion certificate.

Responsibilities

State Fire Training' Responsibility

- Ensuring the Low Angle Rope Rescue Operational training site meets all site requirements.
- Ensuring the course instructor(s) are registered for the level and subject of instruction to be taught.

Student's Responsibility

- Reviewing and understanding instructions in the student manual.
- Satisfactorily completing all course requirements.
- Ensuring their Low Angle Rope Rescue Operational Student Task Book is accurately recorded and maintained.
- Filing and keeping their Low Angle Rope Rescue Operational Student Task Book with their other personal or career records.

Primary Instructor's Responsibility

- Being qualified and proficient.
- Explaining to the students the purpose of and process for completing the Low Angle Rope Rescue Operational Student Task Book.
- Explaining to the students their responsibilities.
- Teaching the required skills and evolutions.
 - If the optional skills and evolutions are scheduled to be taught, adequate time and materials must be added.
- Accurately evaluating and recording on the Low Angle Rope Rescue Operational Student Task Book all course requirements performed by the students.
- Issuing State Fire Training FSTEP certificates for successful course completion.

Instruction for Completing the Task Book

The Low Angle Rope Rescue Operational Student Task Book allows the instructor to record a student's **performance**. These evaluations are made by observing the student's participation in the classroom and their manipulative performance at each skill station.

Task Book Headings

- Student: Enter the student's name.
- Class Dates: Enter the beginning and ending dates of the class.



LOW ANGLE ROPE RESCUE OPERATIONAL



Appendix B: Glossary

- Ambulatory victim.....A victim that is capable of walking.
- Anchor plateA component of rope rescue hardware intended to help organize anchor and system component rigging.
- Basic Operational Level(US&R Type-4) Represents the minimum capability to conduct safe and effective search and rescue operations at incidents involving nonstructural entrapment. Personnel at this level shall be competent at surface rescue that involves minimal removal of debris and building contents to extricate easily accessible victims from damaged, but noncollapsed structures.
- Belay.....The method by which a potential fall distance is controlled to minimize damage to equipment and/or injury to a live load.
- Bending knotA knot used to tie rope or webbing into itself to form a continuous loop, or to join two lengths of material together to extend the length.
- BightThe open loop in a rope or piece of webbing formed when it is doubled back on itself.
- Brake.....Tool used to create friction to slow rope descent.
- BridleSee pre-rig.
- Bollard.....A round nontrussed anchor.
- Cam.....An eccentric or multiply curved wheel mounted on a rotating shaft, used to produce variable or reciprocating motion in another engaged or contacted part.
- CarabinerAn auxiliary equipment system component; an oval or D-shaped metal, load-bearing connector with a self-closing gate used to join other components of a rope system.
- DescenderA device used to create friction to control the movement or descent of the rope.
- DressedA uniform looking knot free of any twists or abnormalities.
- Fixed lineA rope attached to a suitable anchor used for rappelling or ascending a rope.
- Frictioning device.....See descender.
- HitchA knot that attaches to or wraps around an object so that when the object is removed the knot will fall apart.
- KernContinuous parallel fibers throughout the length of the rope, forming its core. The Kern accounts for 75-90% of the rope's breaking strength.
- Kernmantle rescue rope.....Rope consisting of a core (**kern**) and a sheath (**mantle**) that is the primary tool for raising and lowering rescuers, equipment, and victims.
- KnotA fastening, including bights, bends, and hitches, made by tying together lengths of rope or webbing in a prescribed way.
- LifelineRope dedicated solely for the purpose of supporting people during rescue, fire fighting, other emergency operations, or during training evolutions.



LOW ANGLE ROPE RESCUE OPERATIONAL



Appendix B: Glossary

- Training grooveThe "groove" found in the top bar of a brake bar rack.
- US&RUrban search and rescue
- Vector pullProviding deflection in a rope by applying force to the rope perpendicular to the direction of the load.
- WebbingWoven material in the form of a long strip; can be of flat or tubular weave.
- WindlassThe technique of connecting pickets in a windlass picket system to each other with 20-foot lengths of lifeline or webbing.
- WMDWeapons of mass destruction.
- Working endPart of the rope used in forming a knot. (Also known as "loose end" or "bitter end.")

Appendix C: Graphics Index

Chapter 2: Rope Rescue Equipment

- 2-1: Kernmantle Rope
- 2-2: Dynamic Rope Core and Sheath
- 2-3: Static Rope Core and Sheath
- 2-4: Visual Inspection
- 2-5: Rope Washer
- 2-6: Prusik Loop
- 2-7: Flat Construction of Webbing
- 2-8: Shuttle Loom Construction of Webbing
- 2-9: Needle Loom Construction of Webbing
- 2-10: Assembled Load-releasing Device
- 2-11: Class II Harness
- 2-12: Class III Harness
- 2-13: Victim Harness
- 2-14: Carabiner Components
- 2-15: Locking D
- 2-16: Locking Modified D
- 2-17: NFPA Label
- 2-18: Brake Bar Rack with Tie-off Bar
- 2-19: Figure Eight Plate with Ears
- 2-20: Rescue Pulley Components
- 2-21: Prusik Minding Pulley
- 2-22: Round Pulley
- 2-23: Ascender
- 2-24: Anchor Plate
- 2-25: Edge Roller
- 2-26: Edge Guard

Chapter 3: Rescue Knots and Hitches

- 3-1: Rope Terminology
- 3-2: Bight
- 3-3: Loop
- 3-4: Round Turn
- 3-5: Half Hitch from the Loop
- 3-6: Half Hitch on the Loop
- 3-7: Round Turn and Two Half Hitches

Required Knots

- 3-8 – 3-10: Figure Eight Stopper (Steps 1-3)
- 3-11 – 3-13: Figure Eight on a Bight (Steps 1-3)
- 3-14 – 3-16: Overhand Knot (Steps 1-3)
- 3-17 – 3-19: Overhand Bend (Steps 1-3)
- 3-20 – 3-22: Round Turn and Two Half Hitches (Steps 1-3)
- 3-23 – 3-25: Three Wrap Prusik Hitch (Steps 1-3)

Optional Knots

- 3-26 – 3-28: Figure Eight Follow Through (Steps 1-3)
- 3-29 – 3-31: Figure Eight Bend Steps (1-3)
- 3-32 – 3-35: Double Overhand Bend (Steps 1-4)
- 3-36 – 3-38: Clove Hitch, Method 1 (Steps 1-3)

Chapter 7: System Attachments and Fall Restraint

- 7-1: Rescuer Attachment to End of Line
- 7-2: Rescuer Attachment to Ambulatory Victim
- 7-3: Head Lashing 5-foot Webbing
- 7-4: Head Lashing 7-foot Lifeline
- 7-5: Head Lashing Pre-rig
- 7-6: Head Lashing Without an Anchor Plate
- 7-7: Litter Harness Pre-rig
- 7-8: Three Rescuer Litter Attachment Setup
- 7-9: Three Rescuer Litter Attachment
- 7-10: Four Rescuer Litter Attachment Setup
- 7-11: Four Rescuer Litter Attachment
- 7-12: Constructing a Fall Restraint Using a Picket
- 7-13: Constructing a Fall Restraint Using Other than a Picket
- 7-14: Direct, Nonadjustable Attachment
- 7-15: Adjustable Attachment

Chapter 8: Three Main Components of a Rope Rescue System

- 8-1: Belay/Safety Component
- 8-2: Main Line Component (RPM)
- 8-3: Mechanical Advantage Component
- 8-4: Single RPM Configuration Belay/Safety Line
- 8-5: Single RPM Configuration Main Line
- 8-6: Prerigged Dual RPM Systems with Brake Bar Rack
- 8-7: Prerigged Dual RPM Systems with Figure Eight Descender
- 8-8: Prerigged Dual RPM Systems with Brake Bar Rack: As Stored
- 8-9: Prerigged Dual RPM Systems with Figure Eight Plate: As Stored
- 8-10: Prerigged Dual RPM Systems with Brake Bar Rack: In-service Lower
- 8-11: Prerigged Dual RPM Systems with Figure Eight Plate: In-service Lower

Chapter 9: Belay/Safety Line Systems

- 9-1: Belay/Safety Line Basic Configuration
- 9-2: Belay/Safety Line Prusik Minding Pulley Configuration
- 9-3: Lowering Operations – Basic Configuration (Steps 1-5)
- 9-4: Lowering Operations – Basic Configuration (Step 6)
- 9-5: Retrieval Operations – Basic Configuration (Steps 1-5)
- 9-6: Retrieval Operations – Basic Configuration (Step 6)
- 9-7: Lowering Operations – PMP Configuration (Steps 1-5)
- 9-8: Lowering Operations – PMP Configuration (Steps 6)
- 9-9: Retrieval Operations – PMP Configuration
- 9-10: Dual RPMs Basic Configuration – Lower
- 9-11: Dual RPMs PMP Configuration – Retrieve
- 9-12: Belay/Safety Line Single Configuration without PMP
- 9-13: Belay/Safety Line Single Configuration with PMP

Chapter 10: Descending/Ascending

- 10-1: Figure Eight Descender (Eight Plate) with Long Ears
- 10-2: Figure Eight Descender (Eight Plate) with Short Ears
- 10-3: Brake Bar Rack with a Tie-off Bar
- 10-4: Brake Bar Rack without a Tie-off Bar
- 10-5: Line Attachments
- 10-6 – 10-8: Reeve the Figure Eight Descender (Steps 1-3)

Load Releasing Using the Z-rig Method

- 12-3: Reeve the Belay/Safety Line
- 12-4: Form a Three-wrap Prusik
- 12-5: Attach a Carabiner
- 12-6: Prusik Brake Released

Raising Operations

- 12-7: Jammed Load
- 12-8 – 12-13: LRD Set-up (CMC ProSeries Load Release Strap)
- 12-14 – 12-20: Load Releasing Using the LRD

Chapter 13: Rescue Scene Organization and Management

- 13-1: Example Organization Chart

Considerations for the IC

- 13-2: Engine 1 Spot
- 13-3: Engine 2 Spot
- 13-4: Engine 3 Spot
- 13-5: Engine 4 Spot Showing "Down Elevator"

Organization Charts

- 13-6: Step 1 – Scene Assessment and Rigging
- 13-7: Step 2 – Initial Victim Contact
- 13-8: Step 3 – Ambulatory Victim Walkout
- 13-9: Step 4 – Nonambulatory Victim Packaging
- 13-10: Step 5 – Nonambulatory Victim Rescue
- 13-11: Blank Chart

Chapter 14: Litter Walkouts

- 14-1: Caterpillar Walkout Techniques
- 14-2: Single Pitch Walkout with a Belay/Safety Line
- 14-3: Multi-pitch Walkout

Chapter 15: Ladder Systems

Moving Ladder Slide

- 15-1: Moving Ladder Slide
- 15-2: Moving Ladder Slide Components
- 15-3: Rescue Litter at the Foot of the Ladder
- 15-4: Lash the Litter to the Second Rung
- 15-5: Tie a Round Turn and Two Half Hitches
- 15-6: Levering the System
- 15-7: Swing System Up and Out

Ladder Slide

- 15-8: Level Ground Walkout (Litter in the Middle)
- 15-9: Lifting the Basket
- 15-10: Ladder Slide
- 15-11: 2:1 Ladder Rig Components
- 15-12: Assembled 2:1 Ladder Rig
- 15-13: Fly Out for Lowers
- 15-14: Fly In for Raises
- 15-15: Lash Fly to the Bed of the Extension Ladder
- 15-16: Ladder Slide with a 2:1 Ladder Rig

Chapter 16: Evolutions

- 16-1: Access, Stabilize, and Package an Ambulatory Victim for a Low Angle Walkout (One Rescuer)

Appendix D: Training Site Requirements

A Low Angle Rope Rescue Operational Training Site must have facilities, structures, work areas, materials, props, tools, and equipment of adequate size, type, and quantity to fully and safely support the technical and manipulative training required to deliver the Low Angle Rope Rescue Operational curriculum.

(A) Goals

- Set minimum performance training objectives for Low Angle Rope Rescue Operational training programs.
- Identify those performance objectives a Low Angle Rope Rescue Operational Training Site must be capable of supporting.
- Provide the means to ensure proper curriculum delivery.
- Low Angle Rope Rescue Operational Training Sites will meet the minimum requirements to support curriculum delivery.
 - A completed "Request for FSTEP Course Scheduling" providing the dates and location of the upcoming course. The names of all Low Angle Rope Rescue Operational instructors must be included in the application package to support class size.

(B) Site Capacity

A Low Angle Rope Rescue Operational Training Site is evaluated on its ability to deliver the required training. A One-squad Site is the minimum and is capable of delivering training to twelve (12) students or one (1) squad. Additional sites may be capable of delivering training to a maximum of twenty-four (24), thirty-six (36), or forty-eight (48) students simultaneously. Each capacity level represents the maximum number of students or squads that may be taught on the site at any given time. This maximum number will be determined based on the suitability of the site to safely train between twelve (12) and forty-eight (48) students.

- One-squad Site.
 - Supports the instruction for teaching one (1) squad, a maximum of twelve (12) students on the site.
 - One (1) Low Angle Rope Rescue Operational Primary Instructor is required for a student instructor ratio of 12:1.
 - For increased safety/span of control, it is recommended to have two (2) Low Angle Rope Rescue Operational Primary Instructors for a Level 1 site with a student/instructor ratio of 6:1.
- Two-squad Site.
 - Supports the instruction for teaching two (2) squads, a maximum of twenty-four (24) students on the site.
 - Two (2) Low Angle Rope Rescue Operational Primary Instructors are required for a student instructor ratio of 12:1.
 - For increased safety/span of control, it is recommended to have four (4) Low Angle Rope Rescue Operational Primary Instructors for a Level 2 site with a student/instructor ratio of 6:1.

(E) Equipment Standards

- The equipment listed below is the minimum for each Low Angle Rope Rescue Operational Training Site to support one (1) squad or twelve (12) students.
- Student safety is of paramount importance when conducting the type of high-risk training associated with a Low Angle Rope Rescue Operational course.

Low Angle Rope Rescue Operational Equipment Inventory

A Low Angle Rope Rescue Operational Cache is required for each squad. A Four-squad Site, therefore, would require four (4) LARR Operational Caches.

Low Angle Rope Rescue Operational Equipment Inventory All Equipment Must Be NFPA "G" Rated	Size	LARR Ops Cache for each squad	
		Required	Desired
Anchor plate		3	4
Apparatus, fire	Large	2 per site (optional)	
Backboard, long		Optional	1
Brake bar rack		2	4
Carabiner		25	
Commercial Class II harness	Small	2	
Commercial Class II harness	Medium	4	
Commercial Class II harness	Large	4	
Commercial Class II harness	Extra large	4	
Commercial victim seat harness		1	4
Edge protection		2	
Figure eight descender		4	
Gibbs ascender		1	
Ladder	14'	1 per site (optional)	
Ladder	24'	1 per site (optional)	
Load-releasing device		3	4
Low stretch kernmantle rope	½"x150'	3	4
Low stretch kernmantle rope	½"x20'	2	4
Picket, steel	1"x4'	15 per site	
Prusik loop	Short	6	
Prusik loop	Long	6	
Pulley: PMP or standard	2" or 4"	3	6
Pulley: Prusik minding	2" or 4"	2	
Rescue litter		2	4
Rescue litter pre-rig with 4 prusiks and 6 carabiners		2	4
Rescue mannequin		1 per site (optional)	
Sledge hammer	8 – 10 lb.	2 per site	
Spider straps		Optional	2
Tie rope	15'	13	
Webbing, blue tubular	1"x15'	13	
Webbing, green tubular	1"x5'	6	
Webbing, orange tubular	1"x20'	13	
Webbing, yellow tubular	1"x12'	6	

Appendix E: Instructor Levels and Requirements

Instructor Levels

Instructor Trainee

The Instructor Trainee is the entry level for becoming a Primary Instructor for the Low Angle Rope Rescue Operational course and may apply to become a registered Primary Instructor once the educational, course work, and experience criteria have been met. This position is valid for two (2) years after successfully completing a Low Angle Rope Rescue Operational course.

- Under direct supervision of a registered Low Angle Rope Rescue Operational Primary Instructor, the Instructor Trainee will:
 1. Support the logistics of the Low Angle Rope Rescue Operational curriculum being trained in.
 2. Instruct the entire curriculum. This will require participation as an Instructor Trainee in several Low Angle Rope Rescue Operational classes until all topics are taught competently.
 3. Satisfactorily complete a Low Angle Rope Rescue Operational Instructor Trainee Task Book within two (2) years of completing Low Angle Rope Rescue Operational course.

Primary Instructor

Low Angle Rope Rescue Operational Primary Instructor is qualified to instruct a Low Angle Rope Rescue Operational course. During a course delivery, a Primary Instructor is responsible for coordinating and monitoring all safety aspects of the course in addition to supervising and evaluating any Instructor Trainee(s).

The Primary Instructor initiates a class from start to finish, maintains records, and forwards fees and appropriate class documents to State Fire Training.

Instructor Qualifications

Instructor Trainee

To be an instructor trainee for a Low Angle Rope Rescue Operational course for State Fire Training, the following qualifications are required:

Teaching Experience

- None.

Course Work

- Have attended and passed I-200 Basic ICS: ICS for Single Resources and Initial Action.
- Have attended and passed an OSFM Low Angle Rope Rescue Operational course.

Instructor Training

- Any one (1) of the following five (5) options:
 1. Have attended and passed Fire Instructor 1A and 1B.
 2. Have a valid community college teaching credential.
 3. Completed the UC/CSU 60-hour Techniques of Teaching course.

Maintaining Primary Instructor Status

- Attend and pass the OSFM Ethical Leadership in the Classroom course by December 31, 2007.
- Abide by all published procedures of State Fire Training, including signing the Instructor Code of Ethics/Conduct.
- Be the Primary Instructor for at least one (1) State Fire Training Low Angle Rope Rescue Operational class every two (2) years.
- Submit any change of address or phone number.
 1. Department
 2. Home
 3. Cell
 4. Email
- Attend an update course delivered by State Fire Training when required.



LOW ANGLE ROPE RESCUE OPERATIONAL



Appendix F: Instructor Trainee Task Book

Appendix F: Instructor Trainee Task Book

The Low Angle Rope Rescue Operational Instructor Trainee Task Book lists every requirement that will be observed and evaluated by the Primary Instructor. After the Instructor Trainee has demonstrated competency in each area and the task book is complete, he or she may apply to become a registered Primary Instructor once the educational, course work, and experience criteria have been met.

Responsibilities

Instructor Trainee's Responsibility

- Reviewing and understanding all site requirements, equipment standards, and the material in the student manual.
- Satisfactorily completing all instructor requirements.
- Ensuring their Low Angle Rope Rescue Operational Instructor Trainee Task Book is accurately recorded and maintained.
- Filing and keeping their Low Angle Rope Rescue Operational Instructor Trainee Task Book with their other personal or career records.

Evaluating Instructor's Responsibility

- Being qualified and proficient.
- Explaining to the Instructor Trainees the purpose of and process for completing the Low Angle Rope Rescue Operational Instructor Trainee Task Book.
- Explaining to the Instructor Trainees their responsibilities.
- Accurately evaluating and recording on the Low Angle Rope Rescue Operational Instructor Trainee Task Book all course requirements completed by the Instructor Trainees.

Instruction for Completing the Task Book

The Low Angle Rope Rescue Operational Instructor Trainee Task Book allows the evaluating Primary Instructor to record an Instructor Trainee's performance for teaching all aspects of the course. These evaluations are made by observing the Instructor Trainee's presentation abilities and manipulative performance techniques.

Task Book Headings

- Instructor Trainee: Enter the trainee's name.
Class Dates: Enter the beginning and ending date of the class.
Chapter/Title: Lists the chapter number and topic title.
Time Frame: Lists the estimated time frame for teaching the job.
Grade Code: Area to record the Instructor Trainee's performance.
Evaluating Instructor: The Evaluating Instructor enters his or her first and last name.
Date: The Evaluating Instructor enters the date the Instructor Trainee was evaluated.

Evaluator Recommendations

One or more evaluators will complete the Evaluator Recommendation section.



LOW ANGLE ROPE RESCUE OPERATIONAL



Appendix F: Instructor Trainee Task Book

INSTRUCTOR

TRAINEE: _____

CLASS DATES: _____

PERFORMANCE STANDARD: All skills and evolutions must be demonstrated by the Instructor Trainee and evaluated by a Low Angle Rope Rescue Operational Primary Instructor. Skills and evolutions given a "P" in the grade code must be functional and safely taught according to the operations presented in the student manual.

GRADE CODES: "P" - Successfully met the performance standard. "F" - Did not meet the performance standard.

	Chapter/Title	Time Frame	Grade Code	Evaluating Instructor	Date
Instructor Responsibilities					
1	Course Logistics				
2	Course Organization				
3	Course Management				
1 Introduction					
1-1	Course Objectives and Overview				
1-2	Rescuer and Victim Safety				
1-3	Personal Protective Equipment (PPE)				
1-4	Student Evaluation/Task Book				
2 Rope Rescue Equipment					
2-1	Introduction to Rescue Rope and Related Equipment				
3 Rescue Knots and Hitches					
3-1	Introduction to Rescue Knots				
3-2	How to Tie a Figure Eight Stopper				
3-3	How to Tie a Figure Eight On A Bight				
3-4	How to Tie an Overhand Knot				
3-5	How to Tie an Overhand Bend				
3-6	How to Tie A Round Turn With Two Half Hitches				
3-7	How to Attach a Three Wrap Prusik Hitch				



LOW ANGLE ROPE RESCUE OPERATIONAL



Appendix F: Instructor Trainee Task Book

INSTRUCTOR

TRAINEE: _____

CLASS DATES: _____

PERFORMANCE STANDARD: All skills and evolutions must be demonstrated by the Instructor Trainee and evaluated by a Low Angle Rope Rescue Operational Primary Instructor. Skills and evolutions given a "P" in the grade code must be functional and safely taught according to the operations presented in the student manual.

GRADE CODES: "P" - Successfully met the performance standard. "F" - Did not meet the performance standard.

	Chapter/Title	Time Frame	Grade Code	Evaluating Instructor	Date
4-13	How to Construct a 1-1-1 Inline Windlass				
4-14	How to Construct a Triangle Windlass				
5 Rescuer and Ambulatory Victim Packaging					
5-1	Introduction to Rescue Harnesses				
5-2	How to Don a Class II Harness				
5-3	How to Package a Victim in a Commercial Victim Harness				
5-4	How to Package a Victim in a Hasty Pelvic Harness				
6 Types of Rescue Litters and Victim Packaging					
6-1	Introduction to the Rescue Litter				
6-2	How to Secure a Victim to a Rescue Litter				
Optional Rescue Litters and Victim Packaging (Required for Instructor Trainees)					
6-3	How to Secure a Victim to a Rescue Litter, Alternative Method				
7 System Attachments and Fall Restraint					
7-1	Introduction System Attachments and Fall Protection				
7-2	How to Attach a Rescuer to a Rope Rescue System				
7-3	How to Attach an Ambulatory Victim to a Rope Rescue System				
7-4	How to Attach a Rescue Litter to a Rope Rescue System				
7-5	How to Attach a Litter to a Rope Rescue System with Three Rescuers				
7-6	How to Attach a Litter to a Rope Rescue System with Four Rescuers				
7-7	How to Attach a Rescuer to a Fall Restraint System				



LOW ANGLE ROPE RESCUE OPERATIONAL



Appendix F: Instructor Trainee Task Book

INSTRUCTOR
TRAINEE: _____

CLASS DATES: _____

PERFORMANCE STANDARD: All skills and evolutions must be demonstrated by the Instructor Trainee and evaluated by a Low Angle Rope Rescue Operational Primary Instructor. Skills and evolutions given a "P" in the grade code must be functional and safely taught according to the operations presented in the student manual.

GRADE CODES: "P" - Successfully met the performance standard. "F" - Did not meet the performance standard.

	Chapter/Title	Time Frame	Grade Code	Evaluating Instructor	Date
	How to Rappel and Lock-off Using a Figure Eight Descender (Short Ears with Girth Hitch)				
10-6	How to Rappel and Lock-off Using a Brake Bar Rack (With Tie-off Bar)				
	How to Rappel and Lock-off Using a Brake Bar Rack (Without Tie-off Bar)				
10-7	How to Ascend a Fixed Line				
10-8	How to Escape Jammed Friction Devices				
11 Lower/Raise (Mechanical Advantage) Systems					
11-1	Introduction to Rope Rescue Lowering and Raising Systems				
11-2	How to Convert a Lowering System to a Raising System with a 3:1 Inline - RPM				
11-3	How to Operate a Lowering System				
11-4	How to Convert a Lowering System to a Raising System with a 5:1 Inline - RPM				
11-5	How to Convert a Lowering System to a Raising System with a 3:1 or 5:1 Inline with Directional Pulley				
11-6	How to Construct a 3:1 Mechanical Advantage System				
11-7	How to Construct a 5:1 Mechanical Advantage System				
11-8	How to Construct a 3:1 Pig Rig				
11-9	How to Construct a 5:1 Pig Rig				
11-10	How to Convert a Lowering System to a Raising System with a 3:1 Pig Rig				
11-11	How to Convert a Lowering System to a Raising System with a 5:1 Pig Rig				
12 Load-releasing Methods					
12-1	Introduction to Load-releasing Methods				
12-2	How to Construct and Operate a Load-releasing Device				



LOW ANGLE ROPE RESCUE OPERATIONAL



Appendix F: Instructor Trainee Task Book

INSTRUCTOR
TRAINEE: _____

CLASS DATES: _____

PERFORMANCE STANDARD: All skills and evolutions must be demonstrated by the Instructor Trainee and evaluated by a Low Angle Rope Rescue Operational Primary Instructor. Skills and evolutions given a "P" in the grade code must be functional and safely taught according to the operations presented in the student manual.

GRADE CODES: "P" - Successfully met the performance standard. "F" - Did not meet the performance standard.

	Chapter/Title	Time Frame	Grade Code	Evaluating Instructor	Date
Optional Evolutions (Required for Instructor Trainees)					
16-5	Access, Stabilize, Package, and Rescue a Nonambulatory Victim Using Both a Single Litter Walkout and Caterpillar Techniques				
16-6	Access, Stabilize, Package, and Rescue a Nonambulatory Victim Using a Litter Walkout with a Single Pitch Belay				
16-7	Access, Stabilize, Package, and Rescue a Nonambulatory Victim Using a Litter Walkout with Multiple Pitch Belay				
16-8	Access, Stabilize, Package, and Rescue a Nonambulatory Victim using a Moving Ladder Slide				
16-9	Access, Stabilize, Package, and Rescue a Nonambulatory Victim using a Ladder Slide				

